



SCHNEIDER

equipment for professionals

No. 42

 **SCHNEIDER**
equipment for professionals



PIKTOGRAMME / PICTOGRAMS



SB-fähig /
Self-service capability



Gewerbequalität /
Commercial quality



Glaskeramik /
Glass ceramics



Funktionen /
Features



Sicherheit /
Safety



Einfache Bedienung /
Easy to use



Zeitsparend / Induction /
Time saving / Induction



Energiesparend /
Energy efficient



Schuko-Stecker /
Schuko-plug



Spezialbeschichtung /
Special coating



Spülmaschinengeeignet /
Dishwasher-safe



Neuer Artikel /
New article



Schnittfest /
Cut Resistance



Mikrowellengeeignet /
Suitable for microwaves



Nicht bei offenem
Feuer verwendbar /
Not for use with fire



Stapelbar /
Stackable



Schlagfest /
Impact resistant



Backtemperatur
max. 200° C / Baking
temperature max. 200° C



Lebensmittelecht /
Food safe



Recyclebar /
Recyclable



Sperrgut (gesonderte
Frachtkosten) / Bulky goods
(separate freight costs)



Speditionsfracht (gesonderte
Frachtkosten) / Cargo freight
(separate freight costs)

BEZEICHNUNG / DISCRIPTION

#	Artikelnummer	Product code
	Inhalt / Volumen	Content / Volume
↔ mm	Abmessungen / Außenmaße	Outer dimensions
↑ mm	Innenmaße	Internal dimensions
→ mm	Breite	Width
↑ mm	Höhe	Height
↗ mm	Länge	Length
↓ mm	Tiefe	Depth
∅ mm	Durchmesser	Diameter
↑ ∅ mm	oberer Durchmesser	Upper diameter
↓ ∅ mm	unterer Durchmesser	Bottom Diameter
↙ ↗ mm	Div. Maße	Various dimensions
	Spannung / Hz	Voltage / Hz
	Watt	Watt
	Gewicht	Weight
°C	Temperatur	Temperature
	Maschenweite	Mesh width
	Etagen	Floors

A - Z



Inhalt Content		4 – 5	
Stichwortsuche Alphabetical index		6 – 13	
Küchenzubehör & Utensilien Kitchen Accessories & Tools Accessori per Cucina & Utensileria Cocina Accesorios y Herramientas		14 – 77	1
Pizza-Zubehör Pizza Accessories Pizza Accessori Accesorios de pizza		78 – 83	2
Messer Knives Coltelleria Cuchilleria		84 – 105	3
Transportieren & Lagern Transportation & storage Trasporto e Stoccaggio Transporte y almacenamiento		106 – 113	4
Backen Baking Cottura Cocer		114 – 133	5
Backformen Baking moulds Stampi e Tortiere antiaderenti Moldes antiadherentes		134 – 151	6
Silikon-Backformen Silicone baking moulds Stampi in silicone Cocer		152 – 177	7
Ausstecher Cutters Tagliapasta Cortapasta		178 – 197	8
Fachgeräte Utensils Attrezzatura Utensilios		198 – 255	9
Dosiermaschinen / Gebäckfüller Dosingmeter / Cream Injector Dosatrice / Dosatrice per creme Inyectora-dosificadora / Inyector dosificador		256 – 267	10
Thermometer Thermometers Termometri Termometro		268 – 273	11
Arbeitsschutz & Reinigung Protection & cleaning Protezione & Pulizia Protección & Limpieza		274 – 281	12
Dekorieren Decoration Decorazioni Decorar		282 – 307	13
Lebensmittelfarben Food colourings Colori alimentari Colorantes alimentarios		308 – 313	14
Präsentieren Presentation & Display Presentazione Presentar		314 – 345	15
Schokolade Chocolate Cioccolato Chocolate		346 – 381	16
Eis Ice cream Gelato Helado		382 – 387	17
Kellner- / Notablock Waiter and note pads		388 – 389	18
Technische Papiere Technical papers		390 – 393	19
SB-Displays SB-Displays Materialeigenschaften Material characteristics		394 – 395 396 – 397	
Artikelnummern-Index Item number index		398 – 409	

d STICHWORTREGISTER

Artikel	Seite	Artikel	Seite	Artikel	Seite
A					
ABDECKHAUBEN	330	BACKTRENNPAPIERE	126, 127	DECKEL FÜR TÖPFE UND PFANNEN	23
ABREISSGERÄTE	128	BACKTRENNSPRAY FÜR FORMEN UND BLECHE	31, 130	DECKEL INKLUSIVE PUMPE	46
ABREISSVORRICHTUNGEN FÜR FOLIEN	77	BAGUETTEBLECHE	120	DEKOR-AUSSTECHEER-SÄTZE	183 – 1187
ABSTECHEER	213, 214, 216, 351	BEHÄLTERWAGEN	121	DEKOR-BEUTEL	287
ABTROPFLÖFFEL	72	BERLINERTÜLLE	297	DESSERT-RINGE	52, 241, 244, 247
ABWIEGESCHAUFELN	234, 235	BESTECK-KASTEN	60	DONUT-AUSSTECHEER	182
ABZIEHSTAHL	102	BEUTEL FÜR KONTAKTGRILL	29	DONUTFÜLLER	261
ADAPTER FÜR TÜLLEN	293, 303	BLECHANFASSER	275	DOPPELT-INDUKTIONSKOCHFELD	25
AIRBRUSH FARBEN	308, 310	BLUMENSTEMPEL-SET	293	DOSIERGERÄT PRALINENFIX	347
AIRBRUSH KOMPRESSOREN	309	BONHALTER	60	DOSIERMASCHINEN EDHARD	256 – 265
AIRBRUSH-PISTOLEN	309	BRATENTÖPFE	22	DOSIERSPENDER	40 – 47
AIRBRUSH-SET	308	BRATGUTWENDER	54	DREIECK-AUSSTECHWALZEN	205
APFELAUSSTECHEER	65	BRATPFANNEN ALUGUSS	23	DRUCKKNOPF DOSIERSPENDER	44 – 47
APFELSCHÄL- UND TEILMASCHINE	255	BRATPFANNEN ALUMINIUM	23	DRUCKPUMPZERSTÄUBER	229
APFELTEILER	65	BRATPFANNEN EDELSTAHL	23	E	
ARBEITSSCHÜRZEN	279	BREZELSCHIESSER	239	EDHARD	256 – 265
ASPIK-FORMEN	150	BREZEL-SCHNEIDE-SET	94	EIERSTÜCKLER	64
AUFHÄNGEKETTE	45	BREZELSTÄNDER	340	EIERTEILER	64
AUFNAHME / HALTERUNG	171	BRIOCHEFORM	139, 150	EIMER	112
AUFNAHME FÜR LAMMFORM	141	BROT- UND AUFSCNITTMESSER	93	EIMER FÜR DOSIERSPENDER	46
AUSBACKSCHIESSER	238	BROT- UND TEIGDRÜCKER	199	EINWEGHANDSCHUHE	278
AUSBEINMESSER	99	BROTBACKFORM	145	EINWEGHANDSCHUHE ZIP	278
AUSKÜHLPLATTEN	81	BRÖTCHENDRÜCKER	198	EINWEG-SPRITZBEUTEL	289 – 291
AUSLAGETABLETTS	21, 315, 316, 317, 319, 322, 323	BRÖTCHENMESSER	95	EINWEG-SPRITZBEUTEL PERGAMYN	287
AUSSTECHEER	188 – 197	BROTDRÜCKER	198	EINWEG-SPRITZBEUTEL ZIPPER	289
AUSSTECHEERSÄTZE		BROTFORMEN	218, 219, 221	EINWEG-SPRITZBEUTEL-SET	289
AUS EDELSTAHL	180 – 1187	BROTFORMEN ANTIBAKTERIELL	221	EISBEHÄLTER	387
AUSSTECHEERSÄTZE AUS KUNSTSTOFF	178, 179	BROTMESSER	93	EISDIPPER	382
AUSSTECHEMATTEN	190, 191	BROTSTREICHER	201	EISPORTIONIERER	383 – 384
AUSSTELL-/THEKENBLECHE	320, 321	BROTWAGEN-ROST	239	EISSPACHTELN	282
AUSSTELLBLECHE	320, 321	BUFFET- /FISCHGRÄTENPINZETTE	343	EISTÜTENHALTER	385, 386
B					
BABA-FORMEN	150	C		EIWEISSSCHÜSSELN	231
BACK- UND SCHAUMLÖFFEL	58	CLIP FÜR EINWEGHANDSCHUH ZIP	278	EPP AUFSATZRAHMEN	109
BACKBLECHE ALUMINIUM	117, 118, 119	CRÈME BRULÉE-BRENNER	37	ERSATZDECKEL FÜR ISOBOXEN	83, 107 – 109
BACKBLECHE EMAILLE	115	CREME-FORMEN	50	ERSATZKLINGEN	105
BACKBLECHE GRANIT-EMAILLE	114	CREMESCHABER	211, 212	ERSATZ-MESSERBLOCK	63
BACKBLECHE SILIKON	117, 118, 119	CREPES EISEN	30	ERSATZSCHIENE FÜR SCHNITTKUCHENBLECH	124
BACKBLECHE TYNECK	117, 118, 119	CREPES SPATEL	54	ETAGEN-MUFFINSTÄNDER	336
BACKBLECHMESSER	91	CREPES VERTEILER	31	ETAGEN-TORTENSTÄNDER	333 – 337
BACKBLECHVORSETZER	125	CROISSANTSWALZEN	205	F	
BÄCKER-KLINGEN	95	D		FAHRGESTELLE	106, 113, 121, 128
BÄCKERMESSER	85, 92	DARIOIFORMEN	50	FAHRGESTELLE FÜR BACKTRENNPAPIER	128
BACKFORMEN PAPIER	133	DECKEL FÜR EIMER	112	FAHRGESTELLE FÜR KÜBEL	113
BACKHANDSCHUHE	274 – 1277	DECKEL FÜR EISBEHÄLTER	387	FARBSTIFTE	312
BACKHANDSCHUHE SILIKON	73, 277	DECKEL FÜR KÜBEL	113	FEINKOSTLÖFFEL	72
BACKLINEALE	200	DECKEL FÜR MESSBECHER	68, 232	FETTPAPIERHALTER	339
BACKMATTEN	130, 170	DECKEL FÜR MESSERABSTREIFER	103	FILIERMESSER	98
BACKOFENBESEN	281	DECKEL FÜR SCHÜSSEL	66, 224	FISCHZANGE	54
BACKRAHMEN	243, 245	DECKEL FÜR SNACK-TRANSPORTBLECH	110	FLACHBESEN	71, 223
		DECKEL FÜR TEIGWANNE	83	FLASCHEN	229

d STICHWORTREGISTER

Artikel	Seite	Artikel	Seite	Artikel	Seite
FLASCHEN- UND DOSENÖFFNER	62	HOLZSTÄBE	176	KUPFER-EIWEISSSCHÜSSELN	231
FLASCHENWÄRMER	42	HOLZSTIELE	281	KUPFER-KONFITÜRENSCHÜSSELN	230
FLEISCHTÖPFE	22			KUPFER-SIRUPSCHÜSSELN	231
FONDANTTRICHTER	34	I		KUPFER-ZABAIONESCHÜSSELN	230
FRANKFURTER-KRANZFORMEN	135	IGELFORMEN	139	KUPFER-ZUCKERTÖPFE	230
FRANZÖSISCHE TÜLLEN	296	INDUKTIONSKOCHFELDER	24 – 26		
FRISCHHALTEFOLIE	76 – 77	INDUSTRIE-DOSENÖFFNER	62	L	
FRÜCHTE ABLAUF-SET	67, 224			LAMMFORMEN	140, 141
FUSS FÜR HANDSCHLAGKESSEL	227	K		LAMMFORMEN-BATTERIE	141
FUSSBALL FORM	143	KAISERSEMELDRÜCKER	198, 199	LEBENSMITTEL-EISSPRAY	313
FUSSBALLFELD FORM	143	KAMMSCHABER	211	LEBENSMITTEL-FARBSPRAY	312
		KARAMELLISIERER	37	LEBENSMITTEL-GLANZSPRAY	313
G		KARIERHOLZ	208	LEBENSMITTEL-PUDERFARBE	311
GÄRKÖRBE	218, 219, 221	KARTOFFELSTAMPFER	59	LIKÖRTRICHTER	34
GARNIERAUSSTECHER	189	KÄSETORTENFORMEN	136	LIKÖRTÜLLE FÜR PRALINENFIX	347
GARNIERTÜLLEN	298 – 301	KASSENROLLEN HOLZFREI	392	LINERLESS-ENDLOSETIKETTENROLLEN	393
GÄRTÜCHER	220	KASSEROLLE	67, 227, 351	LOCHTÜLLEN	295, 306
GASBRENNER	37	KEBAP-MESSER	84	LOCHTÜLLENSET	306
GASBRENNERAUFSATZ	37	KESSELSCHABER	211, 212	LÖFFELHALTER	386
GASTROHANDSCHUHE	73, 277	KLAMMER FÜR SCHOKOLADEN-FORMEN	354	M	
GAZE-SIEBE	58	KLIMASCHUTZHAUBEN EINWEG	123	MADELEINE-FORMEN	142
GEBÄCKFÜLLER	40, 41, 266, 267	KLIMASCHUTZHAUBEN MEHRWEG	123	MAGNETLEISTEN	103
GEBÄCKKAPSELN	132	KNOBLAUCHPRESSE	65	MARZIPANMESSER	250
GEBÄCKZANGEN	342	KOCHLÖFFEL	54	MARZIPAN-MODELLIERSET	250
GEMÜSEHOBEL	49	KOCHMESSER	96, 97	MARZIPAN-MODELLIERSTÄBE	251
GEMÜSEMESSER	99	KOCHMÜTZEN	280, 281	MASCHINENSCHLAGKESSEL	102, 226
GITTERROSTE	115, 249	KOCHPERGAMENT	29	MASSENRÜHRSPATEL	217
GITTERSCHNEIDER	205	KOCHTÖPFE	22	MEHL- UND ZUCKERSIEBE	237
GLASUR-/ÜBERZIEHGITTER	249	KONDITORLÖFFEL	217	MEHLBESEN	201
GLASURPALETTEN	31, 88, 100	KONDITORMESSER	87, 90	MEHLSIEBE	237
GLASURTRICHTER	252	KONDITOR-SPITZSIEBE	58	MESSBECHER	68, 232
GN-BEHÄLTER EDELSTAHL	18	KONFEKTZANGEN	341	MESSER-ABSTREIFBEHÄLTER	103
GN-BEHÄLTER EDELSTAHL GELOCHT	19	KÖNIGSKUCHENFORMEN	138, 145, 147	MESSSCHAUFLN	234, 235
GN-BEHÄLTER MELAMIN	20	KÖNIGSKUCHENPLATTEN	320	MODELLIERSTÄBE-SET	251
GN-BEHÄLTER PC	17	KONTAKTGRILLE	28	MODELLIERWERKZEUGE	252
GN-BEHÄLTER PE	16	KONVEKTOMATENBLECHE	114, 115	MUFFIN FORMEN	132, 142
GN-BEHÄLTER-DECKEL	16, 17, 19	KRANZFORMEN	135	MUFFIN FORMEN HALLOWEEN	142
GOURMET-PASSIERSIEBE	56	KREIDESTIFTE	340	MUFFINFORMENVERBUNDE	131, 133
GRILL-ODER SERVIERZANGEN	343	KÜBEL	113	N	
GROSSKÜCHENSIEBE	57	KUCHEN- / QUICHE-FORMEN	146, 147	NIESSCHUTZ	340
GUGELHUPF FORMEN	135	KUCHEN-/TORTENGITTER	249	NOTIZBLÖCKE	388
GUMMI FÜR MESSERABSTREIFER	103	KUCHENBLECHE	137, 151	NUDEL-SET GABEL	54
GYROS-MESSER	84	KUCHENBLECHE EMAILIERT	145	NUDEL-SET GREIFER	54
		KUCHENBLECHMESSER	86, 88	O	
H		KUCHENMESSER	86, 87, 91, 97	OBSTTORTENFORMEN	137, 147, 150
HANDBÜRSTEN	220	KUCHENPALETTEN	101	OLIVENENTSTEINER	65
HANDENTSTEINER	255	KUCHENPLATTEN	320	OSTERHASE FORMEN	140
HANDSCHIESSER	79, 239	KÜCHENSIEBE	58	P	
HANDSCHLAGKESSEL	227	KÜHLAKKUS	109	PALETTEN	31, 88, 100
HAUBEN	281	KÜHLAUFSAETZE FÜR ISOBOX	106, 108	PAPIERMÜTZEN	280
HEBELDOSIERSPENDER	40, 41, 46	KÜHLPLATTEN GN	341		
HERZFORMEN	138, 143	KUNSTSTOFF-BAND	331		
HOCHZEITS-TORTENSTÄNDER	333 – 337				

d STICHWORTREGISTER

Artikel	Seite	Artikel	Seite	Artikel	Seite
PASSIERSIEBE	57	RÜHR- UND KNETMASCHINEN	27	SPARSCHÄLER	62
PASTETENAUSSTECHE	49	RÜHRBESEN	71, 223	SPIRALTEIGMASCHINEN	27
PASTETENHALTER	49	RÜHRKEULEN	217	SPITZSIEBE	58
PASTETENMESSER	216	RÜHRSCHÜSSELN	66, 67, 224, 225, 226	SPRINGBLECHE KONISCH	137
PATENTFÖRMCHEN	151	RÜHRSPATEL	59, 217	SPRINGFORM-BODEN	145
PENDELSCHÄLER	62			SPRINGFORMEN	136
PERGAMENTERSATZ	127	S		SPRINGFORMEN EMAILLIERT	145
PETITS FOURS - FÖRMCHEN	148	SACKSCHAUFELN	235	SPRITZBEUTEL "EXPORT"	285
PETITS-FOURS-AUSSTECHE	188	SÄGEBLATTER	246	SPRITZBEUTEL "HAUSHALT"	287
PFANNEN	23	SAHNE-ABDECKPAPIERE	331, 339	SPRITZBEUTEL "MASTERFLEX"	284
PFANNENWENDER	55, 89, 100	SAHNEGERÄTE	36	SPRITZBEUTEL "NYLON SOFT"	286
PINSEL	202, 203	SAHNEKAPSELN	36	SPRITZBEUTEL "PREMIUM"	286
PINZETTEN	54, 343	SALATSCHLEUDER	63	SPRITZBEUTEL "STANDARD"	285
PIZZABLECHE	80, 13	SANDKRANZFORMEN	135, 147	SPRITZBEUTEL-ABSETZSTÄNDER	288
PIZZABOXEN	83	SANDWICH-SCHNEIDE-VORRICHTUNG	64	SPRITZBEUTEL-AUFHÄNGER	288
PIZZAGITTER	81	SAUCEN-LÖFFEL	55	SPRITZTÜLLEN-SET	303
PIZZAÖFEN	83	SAUTEUSEN	23	SPRÜHFLASCHEN	229
PIZZAOFENBÜRSTE	81	SAVARIN-FORMEN	151	SPRÜHPISTOLEN	74, 75, 349
PIZZASCHAUFELN	79	SCHAUFELN	234, 235	SPUCKSCHUTZ	340
PIZZATEILER	82	SCHAUMLÖFFEL	54, 56	STÄBCHEN, PAPPE	171
PIZZAWENDER	100	SCHAUMSPEISERINGE-SET	51	STABMIXER	38, 39
PIZZAZANGE	81	SCHIFFCHEN	149	STÄNDER FÜR PIZZABLECHE	81
PLATTEN	318	SCHILLERLOCKENFORMEN	253	STAPELBEHÄLTER	113
POMMES FRITES- ABTROPFSCHÜSSEL	59	SCHLAGSCHÜSSELN	69, 226	STATIV	231
PORTIONIERER	383 – 384	SCHLESINGER	212	STAUB- UND MEHLSIEB	237
PRALINENFÖRMCHEN	148	SCHNEEBESEN	70, 71, 222, 223	STEG FÜR GN-BEHÄLTER	19
PRALINENGITTER	249	SCHNEIDEBRETTER	104, 105	STERNBANDTÜLLEN	297, 301
PRALINENSCHNEIDER	352	SCHNEIDEBRETTBOBEL	105	STERNTÜLLEN	294, 296, 306
PRALINEN-TUNKGABELN	350	SCHNITTENRAHMEN	200	STERNTÜLLENSET	306
PRALINENTUNKGABEL-SET	350	SCHNITTKUCHENBLECHE	124, 125	STIELE	239
PUDERZUCKERSIEBE	236	SCHOKOLADEN-FONTÄNEN	346	STIELE FÜR LOLLIES	380
		SCHOKOLADEN-FORMEN	355 – 381	STIELKASSEROLLEN	22
		SCHOKOLADEN-FORMEN MAGNET	381	STIELSCHABER	215, 216
		SCHOKOLADEN-TEMPERIERGERÄTE	348, 349	STIELSCHABER LÖFFEL	215
		SCHÖPFER	55, 56	STIELSCHABER SILIKON	215
		SCHÜSSELN	66, 67, 224, 225, 226	STIPPROLLER	204
		SD-PAPIERE	393	STREICHMESSER	95
		SEIHER	67, 224, 225	STREUER	59
		SERVIERLÖFFEL	54	STRUDELWALZEN	204
		SERVIERTABLETTS OVAL	323	STRUKTURBRETTER	250
		SERVIENTENSPENDER	386	SUPPENKELLEN	54
		SIEBE	56, 57, 58, 236, 237		
		SILIKONBACKFORMEN	152 – 177	T	
		SILIKONBACKFORMEN SCHOKOLADE	353	TEFLON-BACKTRENNFOLIEN	129
		SILIKONFÜSSE	21, 314, 319	TEIG- UND DEKORSCHABER	213
		SILIKONMATTEN	163	TEIG- UND PIZZASCHNEIDER	82, 207
		SILIKON-PINSEL	202	TEIGABSTECHE	211, 212
		SNACK-THEKENBLECHE	321	TEIGDOSIERER	31
		SNACK-TRANSPORTBLECHE	110	TEIGSCHABER	136, 210, 211, 212, 216
		SNACK-VERKAUFSSTÄNDER	329	TEIGSCHNEIDER	26
		SOSSENWÄRMER	35	TEIGWANNEN	83, 112, 121, 225
		SPACHTEL	60, 213, 214, 351	TELEFAXROLLEN	3922
		SPAGHETTI LÖFFEL	54	TEMPERIERGERÄTE	348, 349

Q

QUETSCHFLASCHEN	42, 61
QUICHE-FORMEN EMAILLIERT	145

R

RADIESCHENVERZIERER	64
RAHM- UND CREMEROLLEN	253
REFRAKTOMETER	268
REHRÜCKENFORMEN	139
REIBEN	48
RIEFENHÖLZER	208
RINGELBLUMEN FORMEN	143
RINGREIN	129
RODONFORMEN	135
ROHRBODEN FÜR SPRINGFORMEN	136
ROHRFORMEN	253
ROLLHÖLZER	208
ROLLTOP SET	345
ROLLWALZEN	209
RONDEN	129
ROSENTÜLLEN	297

d STICHWORTREGISTER

Artikel	Seite	Artikel	Seite	Artikel	Seite
THEKENABTRENNUNGEN	330				
THEKENAUFSSTELLER	344, 345				
THEKENBLECHE	320, 321				
THEKEN-DISPLAYS	94				
THEKEN-PRÄSENTATIONSSTÄNDER	344				
THEKENPRÄSENTER	345				
THERMO-ECO-HAFTETIKETTEN	393				
THERMOMETER	268 – 273				
THERMOROLLEN	388 – 392				
TIMER	273				
TOASTER	26				
TOMATENSCHNEIDER	63				
TORTELETTIS-FORMEN	146				
TORTENBODENSÄGEN	246				
TORTENBOXEN	110				
TORTENFORMEN	138				
TORTENGITTER	249				
TORTENGITTERSTANZE	200				
TORTENHEBER	342				
TORTENMESSER	88, 90				
TORTENMESSER-ABSTREIFBEHÄLTER	103				
TORTENPLATTEN	324, 325, 326, 328				
TORTENPLATTEN DREHBAR	292, 325				
TORTENRINGE	52, 240 – 246				
TORTENRINGE-SET	241				
TORTENRINGPALETTEN	89, 101				
TORTENSCHNITTEN	242				
TORTENSCHNITTENSTÄNDER	242				
TORTENSPITZEN	332, 333				
TORTENSTÄNDER	333 – 338				
TORTENTEILER	248				
TORTENUNTERSETZER	327				
TORTENZANGEN	342				
TOURNIERMESSER	99				
TRANSFERFOLIEN	381				
TRANSPORTROLLER	106, 121				
TRANSPORTWAGEN	122				
TRENNSPRAY FÜR FORMEN UND BLECHE	31, 130				
TRICHTER	233				
TRÜFFELFÜLLER	34				
TRÜFFELGITTER	249				
TÜLLEN	294 – 307				
TÜLLENBÜRSTEN	293				
TÜLLENKASSETTEN-SET	307				
TUNKGABELN	350				
		V			
		VERBINDUNGSSCHLAUCH	309		
		VERBINDUNGSSTEG	334		
		VERBINDUNGSSTIFT FÜR SCHOKOLADE-FORM	354		
		VERSCHLUSS-CLIPS	292		
		VESPERMESSER	94		
		VITRINE	344		
		VORRATSBEHÄLTER	69, 111		
		VORRATSDOSEN	228, 351		
		W			
		WAFFEL-EISEN	32, 33		
		WANDAUFHÄNGER	228		
		WANDHAKEN	45		
		WANDHALTERUNG FÜR MESSER-ABSTREIFGERÄT	103		
		WASSERSPRÜHPISTOLEN	254		
		WEIHNACHTSSTERN FORMEN	140		
		WELLENMESSER	87		
		WELFHÖLZER	208		
		WIENER-KAISERSEMMELEDRÜCKER	198		
		WINKELPALETTEN	89, 101		
		WOK	26		
		WOLFSZAHNFORM	138		
		WRAP-HALTER	328		
		WURSTSTÄNDER	340		
		WURSTZANGEN	343		
		Z			
		ZANGEN	341		
		ZETTELHALTER	60		
		ZIMTSTERN-AUSSTECHEK	188		
		ZUCKERSTREUER	61		
		U			
		UNIVERSALMESSER	86, 98		
		UNIVERSALREIBEN	49		
		UNIVERSALSCHEREN	102		

gb ALPHABETICAL INDEX

product	page	product	page	product	page
A					
ADAPTER FOR TUBES	293, 303	BREAD KNIVES	87	CONTAINER	228, 351
ADAPTOR BARS	19	BRIOCHE MOULDS	139, 150	COOKING PAPER	29
AIR SPRAYER	229	BRUSH FOR TUBES	293	COOKING SPATULAS	59, 217
AIRBRUSH	309	BRUSHES	202, 203	COOKING SPOONS	54
AIRBRUSH COMPRESSOR	309	BRUSHES SILICONE	202	COOLING PACKS	109
AIRBRUSH FOOD COLOURING	308, 310	BUCKETS	112	COOLING PLATES	81
AIRBRUSH-SET	308	BUCKETS FOR DISPENSER	46	COOLING TOP	106, 108
ANGULAR KNIVES	91	C			
APPLE CORER	65	CAKE BOXES	110	COOLING TRAYS	341
APPLE PEELING AND SLICING MACHINE	255	CAKE DISPLAYS	124, 125	COUNTER DISPLAYS	94
APPLE SLICERS	65	CAKE KNIFE	86, 87, 91, 97	COVER DISPOSABLE FOR UTILITY RACKS	123
APRONS	279	CAKE LIFTERS	342	COVER FOR UTILITY RACKS	123
ASPIC MOULDS	150	CAKE MOULDS	137, 151	CREAM CHARGERS	36
B					
BABA MOULDS	150	CAKE MOULDS – ENAMEL	145	CREAM COVERS	331, 339
BACKING TRAYS EMAILLE	115	CAKE PLATES	324, 325, 326, 328	CREAM DISPENSER	40, 41, 266, 267
BACKING TRAYS GRANITE EMAILLE	114	CAKE PLATES TURNABLE	292, 325	CREAM HORNS	253
BAGS FOR CONTACT GRILLS	29	CAKE SAW	246	CREAM PIPES	253
BAGUETTE TRAYS	120	CAKE SPATULAS	101	CREAM ROLLS	253
BAKER BLADE	95	CAKE STANDS	333 – 337	CREAM SCRAPERS	211
BAKER'S KNIVES	85, 92	CAKE STANDS MUFFIN	336	CREAM TART MOULD	50
BAKING CASES	132	CAKE TONGS	342	CREAM WHIPPERS	36
BAKING FRAMES	243, 245	CAN OPENERS	62	CREPE MAKERS	30
BAKING LINERS	129	CASSEROLE	22	CREPE SLIDERS	31
BAKING MATS	130, 170	CASSEROLE POT	22	CREPE SPATULAS	54
BAKING MITTENS	274 – 277	CENTER SCREW FOR CHOCOLATE MOULDS	354	CROISSANT CUTTERS	205
BAKING MITTENS SILICONE	73, 277	CHAIN	45	CUTLERY TRAYS	60
BAKING MOULDS	133	CHALK PENS	340	CUTTERS	213, 214, 216, 351
BAKING RELEASE PAPERS	126, 127	CHEESE FLAN MOULDS	136	CUTTERS FOR PATE	49
BAKING TRAY SPLINT	125	CHEF'S KNIVES	96, 97	CUTTERS, SET PLASTIC	178, 179
BAKING TRAYS ALUMINIUM	117, 118, 119	CHOCOLATE DIPPING MACHINE	348, 349	CUTTERS, SET STAINLESS STEEL	180 – 187
BAKING TRAYS SILICONE	117, 118, 119	CHOCOLATE FOUNTAINS	346	CUTTING BOARDS	104, 105
BAKING TRAYS TYNECK	117, 118, 119	CHOCOLATE GRATES	249	CUTTING ROLLERS	204
BASTING SPOONS	55	CHOCOLATE MOULD MAGNET	381	CUTTING SHEETS	190, 191
BIRD'S BEAK PEELING KNIVES	99	CHOCOLATE MOULDS	355 – 381	D	
BLENDERS	38, 39	CHOCOLATE TRANSFER SHEETS	381	DECORATING BAGS	287
BLOWTORCHS	37	CHRISTMAS STAR MOULDS	140	DECORATING PINS	208
BOARD SCRAPERS	105	CLEANING BRUSH FOR BREAD PROOFING BASKETS	220	DECORATING TUBES	303
BOAT MOULDS	149	CLINGFILM TEAR-OFF-DISPENSER	77	DESSERT- / TART RINGS	52, 241, 244, 247
BONING KNIVES	99	CLINGFILMS	76 – 77	DIPPING FORK SET	350
BOTTLE WARMERS	42	CLIP FOR CHOCOLATE MOULDS	354	DIPPING FORKS	350
BOTTLES	229	CLIP FOR DISPOSABLE GLOVES ZIP	278	DISPENSERS FOR GREASEPROOF PAPER	40 – 47
BOTTOM FOR SPRING CAKE MOULDS	145	COLANDERS	236	DISPLAY PLATES	21, 315, 316, 317, 319, 322, 323
BOTTOM WITH DOME FOR SPRING MOULDS	136	COMB SCRAPERS	211	DISPLAY TRAYS	320, 321
BOWL STRAINER	57	CONFECTIONARY FUNNELS	34	DISPOSABLE GLOVES	278
BOWLS	66, 67, 224, 225, 226	CONFECTIONER'S KNIVES	87, 90	DISPOSABLE GLOVES ZIP	278
BREAD- AND DOUGHMARKERS	199	CONICAL STRAINERS	58	DISPOSABLE PASTRY BAGS	289 – 291
BREAD BRUSHES	201	CONNECTION	334	DISPOSABLE PASTRY BAGS PERGAMYN	287
		CONTACT GRILLS	28	DISPOSABLE PASTRY BAGS ZIPPER	289
				DOILIES	332, 333

product	page	product	page	product	page
DOLLYS	106, 121	G		LATTICE CUTTERS	205
DOSING METER PRALINENFIX	347	GARLIC PRESSES	65	LATTICE PIE TOP CUTTERS	200
DOSING METER EDHARD	256 – 265	GARNISHING TUBES	298 – 301	LEVER SOUCE DISPENSERS	40, 41, 46
DOUBLE INDUCTION HOB	25	GN LID	16, 17, 19	LID FOR BOWLS	66, 224
DOUGH AND PIZZA CUTTERS	82, 207	GN-CONTAINER MELAMINE	20	LID FOR BUCKET	112, 113
DOUGH CONTAINERS	83, 112, 121, 225	GN-CONTAINER PC	17	LID FOR DOUGH CONTAINER	83
DOUGH DISPENSERS	31	GN-CONTAINER PE	16	LID FOR ICE CREAM CONTAINER	387
DOUGH MARKERS	198	GN-CONTAINER STAINLESS STEEL	18	LID FOR KNIFE CLEANER	103
DOUGH- OR DECORATION COMBS	213	GN-CONTAINER STAINLESS STEEL PERFORATED	19	LID FOR MEASURING CUPS	68, 232
DOUGH SCRAPERS	136, 210, 211, 212, 216	GOURMET BOUILLON-SIEVES	56	LID FOR SNACK TRAY	110
DOUGH WHEEL CUTTERS	26	GOURMET SIEVES	57	LIDS	23
DOUGHNUT CUTTERS	182	GOURMET SPOONS	72	LINERLESS-ENDLESS	393
DOUGHRULERS	200	GRATERS	48	LOAF CAKE MOULDS	138, 145, 147
DREDGERS	59	GRATES	115, 249	LOW FORAGE HATS	280
E		GREASEPROOF PAPER	127	M	
EASTER BUNNY MOULDS	140	GRILL TONGS	343	MADELEINE MOULDS	142
EGG CUTTERS	64	GUGELHUPF MOULDS	135	MAGNET BARS	103
EGG SLICERS	64	GYROS KNIVES	84	MARIGOLD	143
EGG WHITE BOWLS	231	H		MARKING PENS	312
EXTENSION FRAME FOR EPP BOXES	109	HAIR PROTECTIONS	281	MARZIPAN KNIVES	250
F		HEART MOULDS	138, 143	MARZIPAN MODELLING	250
FABRIC FOR ROUND BREAD PROOFING BASKETS	220	HEDGEHOG MOULDS	139	MARZIPAN MODELLING SET	251
FANCY CAKE MOULDS	138	HOLDER FOR CREAM COVERS	386	MEASURING CUPS	68, 232
FASTENING CLIPS	292	HOLDERS	171	MIXING BOWLS	66, 67, 224, 225, 226
FILLETING KNIVES	98	I		MIXING MACHINE	27
FISH TONGS	54	ICE CREAM CONE HOLDERS	385, 386	MODELLING TOOLS	252
FLOUR- AND COCOA-SIEVES	237	ICE CREAM CONTAINERS	387	MOUSSE-FRAME-SETS	51
FLOUR- AND SUGAR-SIEVES	237	ICE CREAM DIPPERS	382	MOUTH BOTTLES	42, 61
FLOUR BRUSHES	201	ICE CREAM PADDLES	282	MUFFIN BAKING MOULDS	132, 142
FLOUR SCOOPS	234, 235	ICE CREAM SCOOPS	383 – 384	MUFFIN BAKING MOULDS HALLOWEEN	142
FLOUR SIEVES	237	INDUCTION HOB	24 – 26	MUFFIN TRAYS	131, 133
FLOWER-NAIL-SET	293	INDUSTRIAL CAN OPENERS	62	N	
FONDANT FUNNELS	252	J		NAPKIN HOLDERS	386
FOOD COLOURS	312	JAM BOWLS	230	O	
FOOD SPRAYS	313	K		OLIVE STONER	65
FOOTBALL FIELD MOULDS	143	KAISERSEMMELE-MARKER	198, 199	OVEN BLADES	79, 239
FOOTBALL MOULDS	143	KEBAP KNIVES	84	OVEN BROOMS	281
FOURWAY GRATERS	49	KITCHEN PINCERS	54, 343	OVEN CLOTHES	275
FRAMES	200	KITCHEN SCISSOR	102	P	
FRENCH FRIES COLANDERS	59	KNIFE CLEANERS	103	PAN TURNERS	55, 89
FRENCH TUBES	296	KNIFE STERILIZER	102, 226	PANS FLIPPER	100
FRITTER TUBES	297	L		PAPER STICKS FOR LOLLIES	380
FRUIT FLAN PANS	137, 147, 150	LABEL-HOLDER	60	PASTA FORKS	54
FRYPAN, ALUMINIUM	23	LADLES	55, 56	PASTA LADLES	54
FRYPAN, ALUMINIUM CAST	23	LAMB MOULD SET	141	PASTRY BAG HOLDER	288
FRYPAN, STAINLESS STEEL	23	LAMB MOULDS	140, 141	PASTRY BAGS "DOMESTIC"	287
FUNNELS	233			PASTRY BAGS "EXPORT"	285

product	page	product	page	product	page
PASTRY BAGS "MASTERFLEX"	284	SAUCE STRAINER	58	STACKABLE BASKETS	113
PASTRY BAGS "NYLON SOFT"	286	SAUCEPANS	67, 227, 351	STAND FOR BREZELS	340
PASTRY BAGS "PREMIUM"	286	SAUCE-WARMERS	35	STAND FOR SAUSAGES	340
PASTRY BAGS "STANDARD"	285	SAUSAGE TONGS	343	STAR CUTTERS	188
PATE MOULDS	49	SAUTEUSE	23	STAR RIBBON TUBES	297, 301
PATENT MOULDS	151	SAVARIN MOULDS	151	STAR TUBES	294, 296, 306
PETITS FOUR MOULDS	148	SAW BLADES	246	STICK, MADE OF PAPER	171
PIPING TUBES	307	SCOOPS	383	STICK, MADE OF WOOD	176
PIZZA CHOPPERS	82	SCRAPERS FLEXIBLE	212	STOCK POTS	22
PIZZA DOUGH BOXES	83	SCRAPERS WITH	211, 212	STRAINERS	67, 224, 225
PIZZA FLIPPERS	100	SCRAPERS WITH REINFORCED GRIP	211, 212	STRUCTURING BOARDS	250
PIZZA MOULDS	80, 13	SERVING PLATES OVAL	323	SUGAR DISPENSERS	61
PIZZA OVEN BRUSHES	81	SERVING SPOON	54	SUGAR PANS	230
PIZZA OVENS	83	SET OF DECORATING CUTTERS	183 –187	SUPPORT FOR CAKE PLATES	242
PIZZA PANS	81	SET OF DISPOSABLE PASTRY BAGS	289	SUPPORT FOR LAMB MOULD	141
PIZZA PEELS	79	SET OF PETITS – FOURS CUTTERS	188	SUPPORT FOR MIXING BOWLS	227
PIZZA SCREENS	81	SHARPENING STEEL	102	SUPPORT FOR PIZZA- AND CAKE MOLDS	81
PLAIN TUBES	306	SHELF FOR BREAD-TROLLEY	239	SWEETS TONGS	341
PLASTIC RIBBONS	331	SHOW CASES	344, 345	SWIVEL PEELERS	62
PLEATED HATS	280, 281	SIEVES	56, 57, 58, 236, 237	SYRUP BOWLS	231
PLUM STONER	255	SILICON MATS	163		
POTATO MASHER	59	SILICONE BAKING MOULDS	152 – 177	T	
POWDER COLOURS	311	SILICONE BAKING MOULDS FOR CHOCOLATE	353	TART- / QUICHE MOULDS	146, 147
PREZELS CUTTING SET	94	SILICONE FEET FOR TRAYS	21, 314, 319	TART COASTERS	327
PROOFING BASKETS	218, 219, 221	SKIMMERS	54, 56	TART DIVIDERS	248
PROTECTION COVERS	330	SLICE WITH DISTANCE CONTROLLER	93	TART RINGS	52, 240 – 246
PROTECTION PLATES	340	SLICER	49	TARTLET MOULDS	146
PUMP DISPENSERS	44 – 47	SLICING MACHINES "GUITARE"	352	TEAR-OFF DISPENSERS	128
		SNACK – SALESRACK	329	THERMOMETERS	268 – 273
Q		SNACK SALES	321	TIMER	273
QUICHE MOULDS – ENAMEL	145	SNACK TRANSPORTBOX	110	TOASTER GRILL	26
		SOUCE DISPENSERS	46	TOMATO SLICER	63
R		SOUCE POTS	22	TONGS	341
RASISHES DECORATOR	64	SOUP LADLES	54	TOOTH OF WOLF SHEET MOULD	138
REFRACTOMETERS	268	SPAGHETTI SPOONS	54	TORCH	37
RELEASE SPRAYS	31, 130	SPARE BLADE FOR BOARD SCRAPER	105	TRAYS – MELAMINE	318
REPLACEMENT JOINT	124	SPATULAS	31, 60, 88, 100, 213, 214, 351	TROLLEYS	106, 113, 121, 128
REPLACEMENT LIDS	83, 107 – 109	SPATULAS ANGULAR	89, 101	TROLLEYS FOR BAKING RELEASE PAPER	128
RIDGED BAKING MOULDS	139	SPATULAS CAKE RING	89, 101	TROLLEYS FOR BUCKETS	113
RINGREIN PAPER	129	SPATULAS SILICONE	215, 216	TRUFFLE FILLERS	34
RODON MOULDS	135	SPATULAS SILICONE SPOON	215	TRUFFLE TUBE PRALINENFIX	347
ROLL KNIVES	95	SPEED PEELER	62	TUBES	294 – 307
ROLLER DOCKERS	204	SPIRAL MIXERS	27	TURNER SLOTTED	54
ROLLING PINS	208	SPONGE CAKE MOULD	135, 147	TWEEZER	343
ROLLTOP SET	345	SPOONS	217		
ROSE TUBES	297	SPRAY GUNS	74, 75, 349	U	
RUBBER FOR KNIFE CLEANER	103	SPRAYING BOTTLES	229	UNIVERSAL KNIVES	86, 98
		SPREADER	95	UTILITY RACKS	122
S		SPRING CAKE MOULDS	136		
SALAD DRYER	63	SPRING CAKE MOULDS – ENAMEL	145	V	
SANDWICH SLICERS	64			VEGETABLE KNIVES	99



gb ALPHABETICAL INDEX

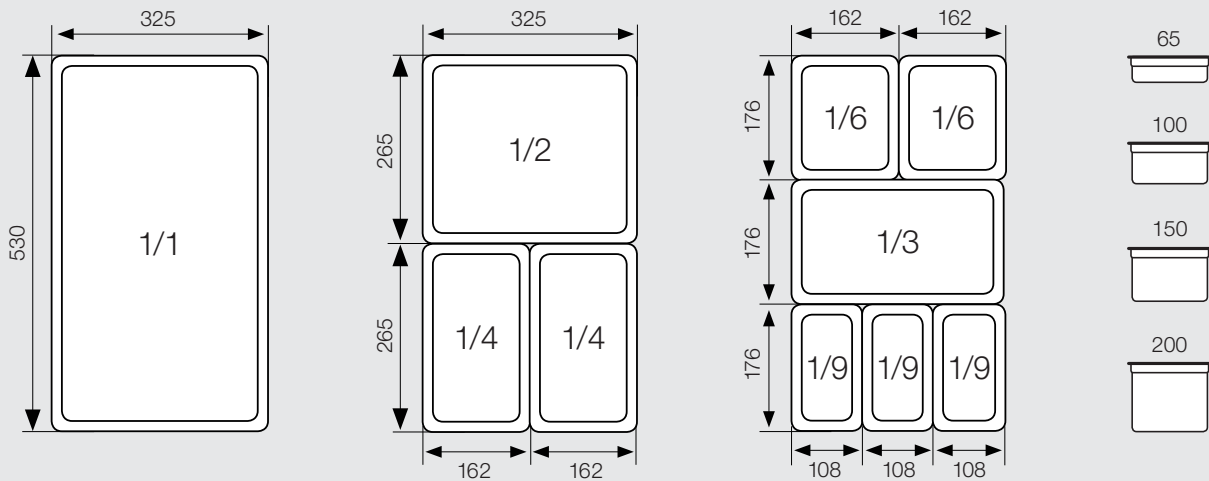

product	page
W	
WAFFLE MAKERS	32, 33
WALL BRAKET FOR KNIFE CLEANER	103
WALL HOOK	45
WALL RACKS FOR CONTAINER	228
WALL RACKS FOR PASTRY BAGS	288
WATER SPRAY GUNS	254
WHISKS	70, 71, 222, 223
WOK PAN	26
WOODEN STICK FOR OVEN BROOMS	281
WRAP HOLDER	328
Y	
YULE LOG MOULD	50

Küchenzubehör & Utensilien
Kitchen Accessories & Tools
Accessori per Cucina & Utensileria
Cocina Accesorios y Herramientas



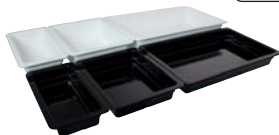



<p>DE GN-BEHÄLTER AUS POLYPROPYLEN GB GN-CONTAINERS MADE OF POLYPROPYLEN IT CONTENITORI GN IN POLIPROPILENE ES CONTENEDORES GASTRONORM POLIPROPILENO</p> <p>Material: Polypropylen (PP). Ideal zum Lagern und Aufbewahren aller Lebensmittel. Einsetzbar von - 30 °C bis ca. + 75 °C, Liter-Skalierung an der Seite. Robust, formstabil und stapelbar.</p> <p>Made of polypropylene (PP). Ideal for storing and keeping all kinds of food. Withstands temperatures from - 30 °C up to ca. + 75 °C, scale on the side. Durable, will not bend or dent, stable and stackable.</p>	 <div style="border: 1px solid black; padding: 5px; display: inline-block;">PP</div>
<p>DE GN-BEHÄLTER AUS POLYCARBONAT GB GN-CONTAINERS MADE OF POLYCARBONATE IT CONTENITORI GN IN POLICARBONATO ES CONTENEDORES IN GASTRONORM POLICARBONATO</p> <p>Material: Polycarbonat (PC). Ideal zum Lagern und Aufbewahren aller Lebensmittel. Einsetzbar von - 40°C bis ca. + 100 °C, Liter-Skalierung an der Seite. Robust, formstabil und stapelbar.</p> <p>Made of polycarbonate (PC). Ideal for storing and keeping all kinds of food. Withstands temperatures from - 40°C up to ca. + 100 °C, scale on the side. Durable, will not bend or dent, stable and stackable.</p>	 <div style="border: 1px solid black; padding: 5px; display: inline-block;">PC</div>
<p>DE GN-BEHÄLTER AUS EDELSTAHL GB GN-CONTAINERS MADE OF STAINLESS STEEL IT CONTENITORI GN IN ACCIAIO INOX ES CONTENEDORES GASTRONORM ACERO INOXIDABLE</p> <p>Aus rostfreiem Chrom-Nickel-Edelstahl 18/10, schwere Qualität, mit elektrolytisch polierter Oberfläche für den professionellen Einsatz.</p> <p>Made of stainless steel 18/10, heavy quality, surface electrolytically polished for professional use.</p>	 <div style="border: 1px solid black; padding: 5px; display: inline-block;">CNS 18/10</div>
<p>DE GN-SCHALEN AUS MELAMIN GB GN-CONTAINERS MADE OF MELAMINE IT CONTENITORI GN IN MELAMINA ES CONTENEDORES GASTRONORM MELAMINA</p> <ul style="list-style-type: none"> • schnitt- und kratzfest, stapelbar • temperaturbeständig von - 30 °C bis + 70 °C <p>• scratch- and cut proof, stackable • temperature resistant from - 30 °C up to + 70 °C</p>	 <div style="border: 1px solid black; padding: 5px; display: inline-block;">MF</div>

DE	GN-BEHÄLTER AUS POLYPROPYLEN	 
GB	GN-CONTAINERS MADE OF POLYPROPYLEN	
IT	CONTENITORI GN IN POLIPROPILENE	
ES	CONTENEDORES GASTRONORM POLIPROPILENO	





#	GN	↑ mm		
530000	1/1	65	8,5	14
530001	1/1	100	13,0	8
530002	1/1	150	19,5	7
530003	1/1	200	26,0	6
530010	1/2	65	3,9	28
530011	1/2	100	5,9	16
530012	1/2	150	8,9	14
530013	1/2	200	11,8	12
530020	1/3	65	2,4	12
530021	1/3	100	3,6	12
530022	1/3	150	5,3	12
530023	1/3	200	7,0	12
530030	1/4	65	1,7	12
530031	1/4	100	2,5	12
530032	1/4	150	3,7	12
530033	1/4	200	5,5	12
530040	1/6	65	1,0	12
530041	1/6	100	1,5	12
530042	1/6	150	2,2	12
530043	1/6	200	3,4	12
530050	1/9	65	0,8	12
530051	1/9	100	1,3	12

DE	GN DECKEL	 
GB	GN LID	
IT	COPERCHIO GN	
ES	TAPA GN	





#	GN	
530005	1/1	12
530015	1/2	12
530025	1/3	12
530035	1/4	12
530045	1/6	24
530055	1/9	24



DE	GN EINSATZ / ABTROPFGITTER	 
GB	GN INSERT / DRAINER PLATE	
IT	GN FALSI FONDI FORATI	
ES	GN FONDO PERFORADO	





#	GN	
530060	1/1	12
530061	1/2	12
530062	1/3	12
530063	1/4	12
530064	1/6	24

DE	GN-BEHÄLTER AUS POLYCARBONAT	 
GB	GN-CONTAINERS MADE OF POLYCARBONATE	
IT	CONTENITORI GN IN POLICARBONATO	
ES	CONTENEDORES IN GASTRONORM POLYCARBONATO	

1

#	GN	↑ mm		
530100	1/1	65	8,5	6
530101	1/1	100	13	6
530102	1/1	150	19,5	6
530103	1/1	200	25,6	6
530110	1/2	65	3,9	12
530111	1/2	100	5,9	12
530112	1/2	150	8,9	12
530113	1/2	200	11,7	12
530120	1/3	65	2,4	12
530121	1/3	100	3,6	12
530122	1/3	150	5,3	12
530130	1/4	65	1,7	12
530131	1/4	100	2,5	12
530132	1/4	150	3,7	12
530140	1/6	65	1	12
530141	1/6	100	1,5	12
530142	1/6	150	2,2	12
530150	1/9	65	0,57	12
530151	1/9	100	0,85	12



DE	GN DECKEL	 
GB	GN LID	
IT	COPERCHIO GN	
ES	TAPA GN	

#	GN	
530105	1/1	12
530115	1/2	12
530125	1/3	12
530135	1/4	12
530145*	1/6	24
530155*	1/9	24

* ohne Griff / without handle



DE	GN DECKEL MIT SILIKONDICHTUNG, DICHTSCHLIESSEND	
GB	GN LID WITH SILICONE SEAL, TIGHTLY CLOSING	
IT	COPERCHIO GN CON GUARNIZIONE IN SILICONE, CHIUSURA ERMETICA	
ES	GN TAPA CON JUNTA DE SILICONE, CIERRE HERMÉTICO	

#	GN	
530160	1/1	1
530161	1/2	1



DE	GN-BEHÄLTER AUS EDELSTAHL
GB	GN-CONTAINERS MADE OF STAINLESS STEEL
IT	CONTENITORI GN IN ACCIAIO INOX
ES	CONTENEDORES GASTRONORM ACERO INOXIDABLE

CNS
18/10



#	GN	↑ mm			
530270	2/1	20	4,5	12	
530271	2/1	40	10,0	12	
530272	2/1	65	16,5	12	



530200	1/1	20	1,9	12	
530201	1/1	40	4,5	12	
530202	1/1	65	7,4	12	
530203	1/1	100	12,6	12	
530204	1/1	150	18,0	12	
530205	1/1	200	25,0	12	



530210	2/3	20	1,25	12	
530211	2/3	40	3,0	12	
530212	2/3	65	5,25	12	
530213	2/3	100	8,0	12	
530214	2/3	150	11,5	12	
530215	2/3	200	16,25	12	



530220	1/2	20	0,85	12	
530221	1/2	40	1,75	12	
530222	1/2	65	3,5	12	
530223	1/2	100	5,5	12	
530224	1/2	150	8,5	12	
530225	1/2	200	11,0	12	



530230	1/3	20	0,6	12	
530231	1/3	40	1,5	12	
530232	1/3	65	2,25	12	
530233	1/3	100	3,5	12	
530234	1/3	150	5,5	12	
530235	1/3	200	7,25	12	





530240	1/4	20	0,4	12	
530241	1/4	40	1,0	12	
530242	1/4	65	1,5	12	
530243	1/4	100	2,5	12	
530244	1/4	150	3,75	12	
530245	1/4	200	5,25	12	

530250	1/6	65	1,0	12	
530251	1/6	100	1,5	12	
530252	1/6	150	2,25	12	
530253	1/6	200	3,0	12	

530260	1/9	65	0,5	12	
530261	1/9	100	0,8	12	

DE	GN-BEHÄLTER AUS EDELSTAHL – GELOCHTE AUSFÜHRUNG	CNS 18/10
GB	GN-CONTAINERS MADE OF STAINLESS STEEL – PERFORATED	
IT	CONTENITORI GN IN ACCIAIO INOX – FORATI	
ES	CONTENEDORES GASTRONORM ACERO INOXIDABLE – PERFORADO	

#	GN	↑ mm		
530300	1/1	65	7,4	12
530301	1/1	100	12,6	12
530302	1/1	150	18,0	12
530310	2/3	65	5,25	12
530311	2/3	100	8,0	12
530312	2/3	150	11,5	12
530320	1/2	65	3,5	12
530321	1/2	100	5,5	12
530322	1/2	150	8,5	12



DE	GN-DECKEL	CNS 18/10
GB	GN LID	
IT	COPERCHIO GN	
ES	TAPA GN	

#	GN	
530206	1/1	12
530216	2/3	12
530226	1/2	12
530236	1/3	12
530246	1/4	12
530256	1/6	12
530266	1/9	12



DE	GN-DECKEL – MIT LÖFFELAUSSPARUNG	CNS 18/10
GB	GN LID – WITH HOLE FOR LADLE	
IT	COPERCHIO GN – CON USCITA PER MESTOLO	
ES	TAPA GN – CUCHARÓN	

#	GN	
530207	1/1	12
530217	2/3	12
530227	1/2	12
530237	1/3	12
530247	1/4	12
530257	1/6	12
530267	1/9	12



DE	STEG FÜR GN-BEHÄLTER	CNS 18/10
GB	ADAPTOR BAR	
IT	SEPARATORE	
ES	BARRA ADAPTA DORA	

#	GN	
530490	1/1	1
530491	1/2	1





DE	GN-SCHALEN AUS MELAMIN	MF
GB	GN-CONTAINERS MADE OF MELAMINE	
IT	CONTENITORI GN IN MELAMINA	
ES	CONTENEDORES GASTRONORM MELAMINA	

Alle Artikel aus Melamin sind:

- spülmaschinengeeignet
- schnitt- und kratzfest, stapelbar
- temperaturbeständig von -30 °C bis +70 °C
- inklusive Silikonfüße

All products made of melamine are:

- dishwasher safe
- scratch- and cut proof, stackable
- temperature resistant from -30 °C up to +70 °C
- including silicone feet



#	GN	● schwarz / black ○ weiss / white	↑ mm	⊞	🛒	
530400	1/1	● schwarz / black	65	8,5	12	
530401	1/1	● schwarz / black	100	13	12	
530410	1/1	○ weiss / white	65	8,5	12	
530411	1/1	○ weiss / white	100	13	12	
530420	1/2	● schwarz / black	65	3,9	12	
530421	1/2	● schwarz / black	100	5,9	12	
530430	1/2	○ weiss / white	65	3,9	12	
530431	1/2	○ weiss / white	100	5,9	12	
530440	1/3	● schwarz / black	65	2,4	12	
530441	1/3	● schwarz / black	100	3,6	12	
530450	1/3	○ weiss / white	65	2,4	12	
530451	1/3	○ weiss / white	100	3,6	12	
530460	1/4	● schwarz / black	65	1,7	12	
530461	1/4	● schwarz / black	100	2,5	12	
530470	1/4	○ weiss / white	65	1,7	12	
530471	1/4	○ weiss / white	100	2,5	12	
530480	1/6	● schwarz / black	100	1,5	12	
530481	1/6	○ weiss / white	100	1,5	12	



Angaben in mm



DE AUSLAGETABLETTS UND AUSLAGESCHALEN
 GB DISPLAY PLATES
 IT VASSOI DI PRESENTAZIONE
 ES BANDEJA DE PRESENTACIÓN

MF

Für Metzgertheke / Fleischertheke mit 84 cm Tiefe. Silikonfüße optional.

Alle Artikel aus Melamin sind:

- spülmaschinengeeignet
- schnitt- und kratzfest, stapelbar
- temperaturbeständig von -30 °C bis +70 °C

For counters in butcher shops with 84 cm depth, silicone feet optional

All products made of melamine are:

- dishwasher safe
- scratch- and cut proof, stackable
- temperature resistant from -30 °C up to +70 °C



#	↔ mm		
227130	280 x 210 x 22	● schwarz / black	48
227131	280 x 210 x 43	● schwarz / black	24
227132	280 x 210 x 76	● schwarz / black	24
227133	420 x 280 x 22	● schwarz / black	18
227134	420 x 280 x 43	● schwarz / black	12
227135	420 x 280 x 76	● schwarz / black	12
227136	280 x 280 x 43	● schwarz / black	24
227137	280 x 280 x 76	● schwarz / black	12
227138	280 x 140 x 43	● schwarz / black	24
227139	280 x 140 x 76	● schwarz / black	24
227140	210 x 140 x 43	● schwarz / black	48
227141	210 x 140 x 76	● schwarz / black	36
227142	Silikonfüße / silicone feet		12



DE	KOCHTÖPFE
GB	STOCK POTS
IT	PENTOLE
ES	OLLA RECTA

Absolute Profi-Qualität, Edelstahl 18/10

- satinierte Oberfläche
- Mehrfach punktgeschweißte Kalt-Griffe
- 8 mm Sandwichboden (Edelstahl, Aluminium, magnetischer Stahl),
- induktionsgeeignet, Schüttrand

High professional quality, stainless steel

- satinized surface
- multiple cold welded handles
- 8 mm sandwich bottom (stainless steel, aluminum, magnetic steel)
- suitable for induction

#	Ø mm	↑ mm	📦 l	🛒
531000	160	150	2,75	1
531001	200	190	5,75	1
531002	240	240	10,5	1
531003	280	280	17	1
531004	320	320	25	1
531005	360	360	36	1
531006	400	400	47,5	1



DE	FLEISCHTÖPFE
GB	SAUCEPOTS
IT	CASSERUOLE ALTE
ES	CACEROLA ALTA

#	Ø mm	↑ mm	📦 l	🛒
531010	160	110	2	1
531011	200	130	3,75	1
531012	240	150	6	1
531013	280	170	10	1
531014	320	190	14,5	1
531015	360	220	20,5	1



DE	BRATENTÖPFE
GB	CASSEROLE POTS
IT	CASSERUOLE BASSE
ES	CACEROLA BAJA

#	Ø mm	↑ mm	📦 l	🛒
531020	160	75	1,5	1
531021	200	90	2,5	1
531022	240	105	4,25	1
531023	280	120	7	1
531024	320	150	11	1



DE	STIELKASSEROLLEN
GB	CASSEROLES
IT	CASSERUOLE BASSE
ES	CACEROLA BAJA

#	Ø mm	↑ mm	📦 l	🛒
531030	160	75	1,5	1
531031	180	80	1,75	1
531032	200	90	2,5	1

DE	DECKEL
GB	LIDS
IT	COPERCHI
ES	TAPA

#	Ø mm	
531060	160	1
531061	200	1
531062	240	1
531063	280	1
531064	320	1
531065	360	1
531066	400	1



DE	SAUTEUSEN
GB	SAUTEUSES
IT	SAUTEUSE
ES	SAUTEUSE

<input checked="" type="checkbox"/>	#	Ø mm	↑ mm		l	
<input checked="" type="checkbox"/>	531040	160	60	0,75	1	1
<input checked="" type="checkbox"/>	531041	180	60	1	1	1
<input checked="" type="checkbox"/>	531042	200	60	1,25	1	1



DE	BRATPFANNEN, ANTIHAFT
GB	FRYPANS, NON-STICK
IT	PADELLE, ANTIADERENTI
ES	SARTÉN, ANTIADHERENTE

Edelstahlpfanne

- Hochwertige 3-lagige Antihafbeschichtung
- Kaltgriff aus Edelstahl

Made of stainless steel

- High-quality 3-layer non-stick coating
- Cold handle made of stainless steel

<input checked="" type="checkbox"/>	#	Ø mm	↑ mm	
<input checked="" type="checkbox"/>	531050	240	45	1
<input checked="" type="checkbox"/>	531051	280	50	1
<input checked="" type="checkbox"/>	531052	320	55	1



Alupfanne für optimale Wärmeleitung

- Hochwertige 3-lagige Antihafbeschichtung
- Kaltgriff aus Edelstahl

Aluminum pan for optimal heat conduction

- High-quality 3-layer non-stick coating
- Cold handle made of stainless steel

<input checked="" type="checkbox"/>	#	Ø mm	↑ mm	
<input checked="" type="checkbox"/>	531070	240	49	1
<input checked="" type="checkbox"/>	531071	280	53	1
<input checked="" type="checkbox"/>	531072	320	60	1
<input checked="" type="checkbox"/>	531073	360	66	1



Alugußpfanne für fettfreies Kochen und Braten

- Kratzfeste Antihafbeschichtung mit Steinpartikeln, kein Anbrennen oder Ankleben
- Schnell, gleichmäßige Hitzeverteilung und lange Wärmespeicherung
- Kaltgriff aus Edelstahl

Aluminium cast pan for fat-free cooking and frying

- Scratch-resistant non-stick coating with stone particles, no burning or sticking
- Fast, even heat distribution
- Cold handle made of stainless steel

<input checked="" type="checkbox"/>	#	Ø mm	↑ mm	
<input checked="" type="checkbox"/>	531076	240	44	1
<input checked="" type="checkbox"/>	531077	280	47	1
<input checked="" type="checkbox"/>	531078	320	55	1



Art. 531078

Gewerbliche Induktionsgeräte Industrial Induction Counter Tops



2800 WATT
Art.-Nr. 147000



DE	INDUKTIONSKOCHFELD
GB	INDUCTION HOB
IT	PIASTRA AD INDUZIONE
ES	PLACE DE INDUCCION

- | | |
|--|---|
| <ul style="list-style-type: none"> • Für den voll gewerblichen Einsatz • Starke Glaskeramik-Oberfläche • Edelstahlgehäuse • Touchpad Bedienfeld und Digitalanzeige • Heizstufen 1 – 12 oder 3 voreingestellte Stufen (550 W, 1500 W, 2800 W) • Timerfunktion (bis 99 min.) • Topftest-Funktion • Kabellänge: 1,4 m. • Spannung 230 V, 50/60 Hz • 12 Monate Vollgarantie, 12 Monate Teilegarantie (außer Glasschäden) | <ul style="list-style-type: none"> • For commercial use • Strong ceramic surface • Stainless steel case • Touchpad control panel and digital display • Heat settings 1–12 or 3 preset levels (550 W, 1500 W, 2800 W) • Timer function (up to 99 min.) • Pan-test function • Cable length: 1,4 m. • Voltage 230 V, 50/60 Hz • 12 month full warranty, 12 month parts warranty (except glass damages) |
|--|---|



#	↔ mm		kg	
147000	365 x 77 x 460	2800	6,0	1



<p>GEWERBEQUALITÄT</p> <ul style="list-style-type: none"> • Hochwertige Glaskeramik • Edelstahlgehäuse • Kabellänge: 1,4 Meter <p>COMMERCIAL QUALITY</p> <ul style="list-style-type: none"> • High-quality ceramic glass • Cable length: 1,4 meters 	<p>GLASKERAMIK</p> <ul style="list-style-type: none"> • Kein Einbrennen • Einfache Reinigung mit einem feuchten Stofftuch <p>CERAMIC</p> <ul style="list-style-type: none"> • No burning in • Simple cleaning with a towel 	<p>FUNKTIONEN</p> <ul style="list-style-type: none"> • Timerfunktion bis 99 Minuten <p>FEATURES</p> <ul style="list-style-type: none"> • Timer function up to 99 minutes 	<p>SICHERHEIT</p> <ul style="list-style-type: none"> • Alle Geräte haben eine automatische Toperkennung • Nur ferromagnetische Töpfe können erhitzt werden <p>SAFETY</p> <ul style="list-style-type: none"> • All units have an automatic pan detection • Only ferromagnetic pans may be heated
<p>EINFACHE BEDIENUNG</p> <ul style="list-style-type: none"> • Einfache und schnelle Einstellung auf der Glasoberfläche oder dem Display <p>EASY HANDLING</p> <ul style="list-style-type: none"> • Easy and quick setting on the glass surface or the display 	<p>ZEITSPAREND</p> <ul style="list-style-type: none"> • Deutlich schneller als Elektroherde <p>TIME-SAVING</p> <ul style="list-style-type: none"> • Much faster than an electric stove 	<p>ENERGIESPAREND</p> <ul style="list-style-type: none"> • Schnelles + direktes Erhitzen • Energiesparend • Umweltschonend <p>ENERGY SAVING</p> <ul style="list-style-type: none"> • Fast and direct heating • Energy-saving • Environmentally friendly 	<p>ÜBERALL EINSETZBAR</p> <ul style="list-style-type: none"> • Alle Induktionsgeräte mit 230 Volt-Schucko-Stecker • Kabellänge: 1,4 Meter <p>USEABLE EVERYWHERE</p> <ul style="list-style-type: none"> • All induction devices with 230 volt safety plug • Cable length: 1,4 m

DE	INDUKTIONSKOCHFELD
GB	INDUCTION HOB
IT	PIASTRA AD INDUZIONE
ES	PLACE DE INDUCCION

- Für den voll gewerblichen Einsatz
 - Starke Glaskeramik-Oberfläche
 - Edelstahlgehäuse
 - Touchpad Bedienfeld und Digitalanzeige
 - Heizstufen 1 – 12
 - Timerfunktion (bis 99 min.)
 - Topftest-Funktion
 - Kabellänge: 1,4 m.
 - Spannung 230 V, 50/60 Hz
 - 12 Monate Vollgarantie, 12 Monate Teilegarantie (außer Glasschäden)
 - Größe Induktionskochfeld: 210 mm
- For commercial use
 - Strong ceramic surface
 - Stainless steel case
 - Touchpad control panel and digital display
 - Heat settings 1-12
 - Timer function (up to 99 min.)
 - Pan-test function
 - Cable length: 1,4 m.
 - Voltage 230 V, 50/60 Hz
 - 12 month full warranty, 12 month parts warranty (except glass damages)
 - Inductor dimension: 210 mm

#	↔ mm		 kg	
147010	280 x 104 x 367	3000	4,5	1
147020	390 x 104 x 450	3500	6,1	1



3000 WATT
Art.-Nr.
147010





3500 WATT
Art.-Nr.
147020



DE	DOPPELINDUKTIONSKOCHFELD
GB	DOUBLE INDUCTION HOB
IT	DUPLICE PIASTRA AD INDUZIONE
ES	DOBLE PLACE DE INDUCCION

- Für den voll gewerblichen Einsatz
 - Starke Glaskeramik-Oberfläche
 - Edelstahlgehäuse
 - Touchpad Bedienfeld und Digitalanzeige
 - Heizstufen 1 – 32
 - Warmhaltefunktion (+ / - 70° C)
 - 2 x 210 mm Induktionsspulen
 - Timerfunktion (bis 99 min.)
 - Topftest-Funktion
 - Kabellänge: 1,4 m.
 - Spannung 230 V, 50/60 Hz
 - 12 Monate Vollgarantie, 12 Monate Teilegarantie (außer Glasschäden)
- For commercial use
 - Strong ceramic surface
 - Stainless steel case
 - Touchpad control panel and digital display
 - Heat settings 1–32
 - Warming function
 - 2 x 210 mm induction spool
 - Timer function (up to 99 min.)
 - Pan-test function
 - Cable length: 1,4 m.
 - Voltage 230 V, 50/60 Hz
 - 12 month full warranty, 12 month parts warranty (except glass damages)

#	↔ mm		 kg	
147030	590 x 385 x 105	3000	10,0	1



3000 WATT
2 x 1500
Art.-Nr.
147030





3500
WATT
Art.-Nr.
147100



DE	INDUKTIONSKOCHFELD "WOK"
GB	INDUCTION HOB "WOK"
IT	PIASTRA AD INDUZIONE "WOK"
ES	PLACE DE INDUCCION "WOK"

- Für den voll gewerblichen Einsatz
 - Durchmesser 350 mm
 - Starke Glaskeramik
 - Edelstahlgehäuse
 - Touchpad Bedienfeld und Digitalanzeige
 - 20 Leistungsstufen (50 – 3500 W)
 - Timerfunktion (bis 99 min.)
 - Topftest-Funktion
 - Kabellänge: 1,4 m.
 - Spannung 230 V, 50/60 Hz
 - 12 Monate Vollgarantie, 12 Monate Teilgarantie (außer Glasschäden)
- For commercial use
 - Diameter 350 mm
 - Strong ceramic
 - Stainless steel case
 - Touchpad control panel and digital display
 - 20 power levels (50 – 3500 W)
 - Timer function (up to 99 min.)
 - Pan-test function
 - Cable length: 1,4 m.
 - Voltage 230 V, 50/60 Hz
 - 12 month full warranty, 12 month parts warranty (except glass damages)

#	↔ mm	🔌	⚖️ kg	🛒
147100	390 x 156 x 429	3500	9,9	1

DE	WOK
GB	WOK
IT	WOK
ES	WOK

Material: Edelstahl
Wok mit halbrund gearbeitetem Boden
Geeignet für Wok-Induktionskochplatte # 147100

Made of stainless steel,
WOK with semi-round bottom
Suitable for induction hob # 147100

#	Ø mm	↑ mm	🔌	🛒
147105	350	100	5,0	1

DE	TOASTER / ÜBERBACKGERÄT
GB	TOASTER / TOASTER
IT	TOSTAPANE
ES	TOSTADORA

- Aussengehäuse Edelstahl
 - mechanische Zeitschaltuhr
 - für bis zu 12 Toasts
 - Ober- und Unterhitze
 - schnelle Quarzheizung
 - Temperatur regelbar von 0° bis 210°C
 - 2200 Watt; 50 / 60 Hz; 230 Volt
- Stainless steel outer housing
 - mechanical timer
 - for up to 12 toasts
 - upper and lower heat
 - fast quartz heating
 - temperature adjustable from 0° to 210°C
 - 2200 W; 50 / 60 Hz; 230 volts



#	↓ mm	→ mm	↑ mm	🛒
150640	430	580	305	1

DE	PLANETEN-RÜHRMASCHINE „CHEF 9000“
GB	MIXING AND KNEADING MACHINE „CHEF 9000“
IT	IMPASTATRICE ELETTRONICA „CHEF 9000“
ES	BATIDORA MEZCLADORA „CHEF 9000“

- | | |
|---|--|
| <ul style="list-style-type: none"> • Volumen: 7,5 Liter • Schüssel Ø: 235 mm / Höhe: 205 mm • Rührgeschwindigkeit stufenlos regelbar • Gehäuse aus lackiertem Stahl • Rührschüssel aus rostfreiem Edelstahl • Sicherheitsschutzgitter mit Mikroschalter • inklusive Schneebesens, Haken und Rührbesen • Spannung 230 V, 50 Hz | <ul style="list-style-type: none"> • Capacity: 7,5 liters • Bowl Ø: 235 mm / H: 205 mm • Variable speed • Housing made of varnished steel • Mixing bowl made of stainless steel • Safety screen for protection and security • Including whisk, hook and beater • Voltage 230 V, 50Hz |
|---|--|

#	↔ mm	⚡	⚖ kg	🛒
159900	420 x 250 x 420 mm	325 W	17,5	1



DE	SPIRALTEIGMASCHINEN
GB	SPIRAL MIXER
IT	IMPASTATRICI A SPIRALE
ES	BATIDORA



- | | |
|--|--|
| <p>Kessel, Kneter und Antrieb aus verstärktem Edelstahl</p> <ul style="list-style-type: none"> • Kugelgelagertes Getriebe • Antrieb mit Induktionsmotor • Gehäuse pulverbeschichtet | <p>High resistance stainless steel bowl, spiral and shaft</p> <ul style="list-style-type: none"> • Ball bearing transmission • induction motor • Body made of non-toxic powdered epoxy. |
|--|--|

#	153640	153650
	Alexo Mix8	Alexo Mix12
🗑️	8	12
Teig-Kapazität / dough capacity kg	6	10
Ø Schüssel / Ø bowl	26	28
⚡ (Induktionsmotor / induction motor)	250	300
🔌 / Hz	220 V / 50 – 60	220 V / 50 – 60
⚖ kg	30	34
Umdrehungen / min. / RPM	68 – 208	68 – 208
→ mm	280	300
↗ mm	490	510
↑ mm	390	450



DE	KONTAKTGRILL
GB	CONTACT-GRILL
IT	GRIGLIE A CONTATTO
ES	CONTACTO GRILL



- Edelstahlgehäuse
- gusseiserne Backplatte
- einstellbare Plattenhöhe
- herausnehmbare Auffangschale
- einstellbare Griffspannung
- Batteriebetriebener und herausnehmbarer akustischer Timer *
- Stainless Steel Housing
- Cast iron plate
- Height of plate may be adjusted
- Removable drip cup
- Adjustable handle
- Battery-operated and removable timer *, including acoustic signal



Art. 150900



Art. 150910



Art. 150920





Art. 150930

#	CE	150900 *	150910 *	150920 *	150930 *
		Kontaktgrill – klein gewellt / gewellt	Kontaktgrill – klein gewellt / glatt	Kontaktgrill – gross gewellt / gewellt	Kontaktgrill – gross gewellt / glatt
Grillfläche / grill area mm		240 x 260	240 x 260	290 x 380	290 x 380
↓ mm		420	420	420	420
→ mm		290	290	410	410
↑ mm		245	245	245	245
⚡		2000 W 50 / 60 Hz / 230 Volt	2000 W 50 / 60 Hz / 230 Volt	2400 W 50 / 60 Hz / 230 Volt	2400 W 50 / 60 Hz / 230 Volt
°C		60 bis 300	60 bis 300	60 bis 300	60 bis 300

DE	BEUTEL FÜR DEN KONTAKTGRILL ODER OFEN "SNACKMULTIBAG"
GB	POUCH FOR THE CONTACT GRILL OR OVEN "SNACKMULTIBAG"
IT	SACCHETTI PER GRIGLIAIO FORNO "SNACKMULTIBAG"
ES	BOLSA DE HORNO "SNACKMULTIBAG"

- Der Kontaktgrill bleibt sauber: Auslaufen der Käse bleibt im SnackMultiBag und verschmutzt den Kontaktgrill nicht mehr. Der Kontaktgrill muss nicht mehr mühsam geputzt werden.
- Kein Geschmack von verbranntem Käse.
- Das Papier ist hitzeresistent bis 220°C: Der SnackMultiBag ist bis 220°C bestens hitzeresistent und komplett ofentauglich.
- Das Papier ist Fett abstoßend: Das Material ist dicht gegen das Auslaufen von schmelzendem Käse.
- Verschiedene Formate: Der SnackMultiBag kann auf Anfrage in verschiedenen Formaten hergestellt werden.
- The contact grill stays clean: Leaking cheese stays in the bag and does not get onto the contact grill.
- No more burnt cheese on the contact grill. Therefore no more smell of burnt cheese and no work to clean the contact grill.
- The SnackMultiBag is heat resistant and certified up to 220°C: The SnackMulti-Bag is adequately heat resistant for any standard oven.
- The paper is grease repellent: The material is grease repellent, melted cheese will stay in the bag.
- Different formats: On demand, the SnackMultiBag can be produced in different formats.

#	←→ mm	
105000	105 x 40 x 320	600
105010	170 x 40 x 160	600
105020	170 x 40 x 205	500

 Individueller Druck ab 25.000 Stück und individuelles Format ab 100.000 Stück möglich!
Individual prints starting at 25,000 pcs. and customized formats as of 100,000 units possible!



1



DE	KOCHPERGAMENT
GB	COOKING PAPER
IT	CARTA PER COTTURA
ES	PAPEL DE HORNO PARA COCINAR

Kochpergament, fett dicht, koch- und dampf-
beständig. Es eignet sich für die Tiefkühlung,
für den Backofen, den Dampfgarer und die
Mikrowelle. Beidseitig silikoniert
Grammatur: 41 g/m². Max. 220 °C

Cooking paper is fatproof, resistant to boiling
and steam. It is suitable for freezer, oven,
steam cooker and microwave. Silicone
coated on both sides Grammage: 41 g / m².
Max. 220 °C

#	←→ mm		
107910	GN 1/1 – 325 x 530	Bogen / sheets	500
107911	380 x 50 m	Rolle / roll	12
107912	GN 1/2 – 330 x 270	Spenderbox / box	100



NEW



Art. 150600

CE



DE	CREPES-EISEN – ELEKTRISCH
GB	CREPE MAKER
IT	CREPIERA TONDA
ES	MÁQUINA PARA CREPES

Platten-Durchmesser: 40 cm,
Teflon-Beschichtung, Aussengehäuse
Edelstahl, Temperatur stufenlos regelbar
(140°C – 300°C), geringer Energieverbrauch,
inklusive Spatula und Verteiler

plate diameter 40 cm, teflon-coated,
body housing made of stainless steel,
temperature continuously adjustable
(140°C – 300°C), low energy consumption,
including drawer and stick

#	150600	150610
Ø mm	400	400
↓ mm	400	445
→ mm	400	430
↑ mm	125	175
⚡	2700 W 50 / 60 Hz 230 V	2700 W 50 / 60 Hz 230 V
°C	140 – 300	140 – 300



Zubehör

NEW



Art. 150610

CE

DE	CREPES-SCHIEBER
GB	CREPE SLIDERS
IT	STENDI PASTELLA PER CREPE
ES	CORREDERA

#	↔ mm		
157760	180 x 185	Holz / wood	1
157770	180 x 180	Edelstahl / stainless steel	1



1

DE	CREPES-WENDER
GB	CREPE SPATULA
IT	SPATOLA PER CREPE
ES	ESPÁTULA CREPE

#	↗ mm	→ mm	
262636	360	34	1



DE	TEIGDOSIERER
GB	DOUGH DISPENSER
IT	DOSATORE PER PASTE
ES	DOSIFICADORE PARA LA PASTA

Zum manuellen Dosieren von flüssigem Teig
Behälter aus Edelstahl
Inklusive Ständer

For manual dough portioning
Body made of stainless steel
Including stand

#	Ø mm	↑ mm	⬇ l	
152975	167	395	2,0	1



DE	BACK-TRENNSPRAY FÜR FORMEN UND BLECHE
GB	RELEASE SPRAY FOR BAKING TINS AND TRAYS
IT	STACCANTE IN SPRAY ANTI ADERENTE
ES	DESMOLDEANTE EN SPRAY

Der perfekte Trennspray für Bäckereien, Konditoreien, Küchen und Gastronomie. Speziell für WALTER-Backformen geeignet. Kein Anbacken oder Ankleben der Backwaren; keine Rückstände in der Form oder auf dem Blech. Reines Lebensmittel, 100 % geschmacksneutral. Zutaten: Pflanzliche Öle; Carnaubawachs; Emulgator: Sonnenblumenlecithine; Treibgas: Propan/Butan.

Nur zur gewerblichen Verarbeitung. Nicht für Luftfracht zugelassen.

The ideal release spray for bakeries, confectioneries, hotel – and restaurant kitchens. Especially suitable for Walter Baking Moulds. Prevents baked goods from sticking to baking moulds / baking trays. 100 % safe for consumption and neutral taste. Ingredients: Vegetable Oils; Carnauba Wax; Emulsifier: Sunflower Lecithin; Propellant: Propane/Butane

For professional use only. Not permitted for transport via Airfreight.

#	⬇ ml		
266960	500	Butan / Propan	12



DE	WAFFEL-EISEN MIT DIGITALEM TIMER
GB	WAFFLE MAKERS WITH DIGITAL TIMER
IT	MACCHINE PER CIALDE CON TIMER DIGITALE
ES	GOFRERA PROFESIONAL



- Edelstahlgehäuse
 - Mit isoliertem Griff
 - Abnehmbare Fettauffangschale
 - Gusseiserne Backplatte, fest montiert
 - Schnelle und zweiseitige Heizungsversorgung
 - Gleichmäßige Temperaturverteilung
 - Heizung regelbar (60° bis 300°C)
 - Batteriebetriebener und herausnehmbarer akustischer Timer *
- Stainless steel case
 - With insulated handle
 - Removable grease tray
 - Cast iron baking plate, permanently mounted
 - Fast and two-sided heating supply
 - Even temperature distribution
 - Heating adjustable (60° to 300°C)
 - Battery-operated and removable timer *, including acoustic signal



Art. 150700



Art. 150710



Art. 150720



#	CE	150700 *	150710 *	150720 *
		„QUADRO“	„HERZ“	„BELGIEN“
Waffeln / Waffle mm		2 100 x 185	4 x ▲ 100	2 100 x 185
↓ mm		420	420	420
→ mm		300	300	300
↑ mm		295	295	295
⚡		1600 W 50 / 60 Hz / 230 Volt	1600 W 50 / 60 Hz / 230 Volt	1600 W 50 / 60 Hz / 230 Volt
°C		60° bis 300°C	60° bis 300°C	60° bis 300°C

DE	WAFFEL-EISEN MIT DIGITALEM TIMER – 180° DREHBAR
GB	WAFFLE MAKERS WITH DIGITAL TIMER – 180°
IT	MACCHINE PER CIALDE CON TIMER DIGITALE – 180°
ES	GOFRERA PROFESIONAL – 180°

- Edelstahlgehäuse
- Mit isoliertem Griff
- Abnehmbare Fettauffangschale
- Gusseiserne Backplatte, fest montiert
- Schnelle und zweiseitige Heizungsversorgung
- Gleichmäßige Temperaturverteilung
- Heizung regelbar (60° bis 300° C)
- Batteriebetriebener und herausnehmbarer akustischer Timer*
- Stainless steel case
- With insulated handle
- Removable grease tray
- Cast iron baking plate, permanently mounted
- Fast and two-sided heating supply
- Even temperature distribution
- Heating adjustable (60° to 300° C)
- Battery-operated and removable timer*, including acoustic signal



#	CE	150790 *
		„180° – drehbar“ „QUADRO“
Waffeln / Waffle mm		2 110 x 185
↓ mm		540
→ mm		305
↑ mm		300
		1800 W 50 / 60 Hz / 230 Volt
°C		60° bis 300° C



DE	LIKÖR- UND FONDANTRICHTER
GB	CONFECTIONERY FUNNEL
IT	IMBUTI COLATORI
ES	EMBUDOS COLADORES



Material: Edelstahl
ergonomischer Griff aus Kunststoff, mit 3
Dosiertüllen (2, 4 und 6 mm), inklusive
Ständer und Auffangschale

made of stainless steel,
ergonomic handle made of plastic,
with three different nozzles
(2, 4 und 6 mm), wire rack and
dripping dish

#	Ø mm	↑ mm	📦 l	🛒
199920	190	220	1,9	1



Material: Edelstahl
mit 3 Dosiertüllen (4,5 und 6 mm),
inklusive Ständer.

made of stainless steel,
with three different nozzles
(4,5 and 6 mm), wire rack.

#	Ø mm	↑ mm	📦 l	🛒
199999	190	230	1,5	1

DE	TRÜFFELFÜLLER
GB	TRUFFLE FILLER
IT	IMBUTI COLATORI
ES	EMBUDOS COLADORES



Material: Edelstahl, lebensmittelechter
Kunststoff. Stufenlose und genaue Mengen-
einstellung von 1 bis 17 g. Universell zum
Füllen mit Quark, Pudding, Ganache, Likör,
Marmelade, Creme. Gewicht: 0,7 kg

Made of stainless steel, food-safe plastic
Stepless and precise adjustment 1 – 17 g
For cottage cheese, pudding, ganache,
liqueurs, jam, cream
Weight: 0,7 kg

#	Ø mm	↑ mm	📦 l	🛒
199950	300	200	1,0	1

DE	SOSSEN-WÄRMER
GB	SAUCE-WARMER
IT	SALSA PIÙ CALDA
ES	CALENTADOR DE SALSAS

Material: Edelstahl

Zum Warmhalten und Dosieren von flüssigen Speisen wie Soßen, Cremes, Schokolade, Füllungen, etc.

Temperatur von + 40° C bis + 70° C einstellbar, inklusive herausnehmbarer Auffangschale

Kein Wasserbad – Temperatureaustausch erfolgt über Direktkontakt / Luft

Trichter: Volumen 2 Liter, inklusive Deckel und 3 Dosiertüllen

Made of stainless steel

For keeping warm and dosing liquid foods such as sauces, creams, chocolate, fillings, etc.

Temperature adjustable from + 40° C to + 70° C, including removable drip tray

No water bath - temperature exchange via direct contact / air

Funnel: Volume 2 litres, including lid and 3 dosing nozzles



#	150590
→ mm	350
↗ mm	285
↑ mm	370
📦 l	8,0
🔌	300 W
🔌	220 – 240 V / 50/60 Hz
⚖️ kg	4,8
🛒	1





DE	SAHNEGERÄTE
GB	CREAM WHIPPERS
IT	SIFONE DA PANNA
ES	SIFÓN MONTADOR DE NATA

#	l		
196000	0,5	1	
196010	1,0	1	



DE	SAHNEKAPSELN
GB	CREAM CHARGERS
IT	CARTUCCIE (PER SIFONE DA PANNA)
ES	RECARGA PARA SIFÓN

#	Menge / amount		
196015	10	1 Set	
196020	24	1 Set	
196030	50	1 Set	



Nicht für Luftfracht zugelassen. / Not permitted for transport via Airfreight.

DE	KARAMELLISIERER / GASBRENNER
GB	SUGAR / BLOWTORCH / CAMELIZER
IT	CANNELLO
ES	FLAMBEADOR

für Crème Brulée, Karamellisieren von Speisen aller Art etc.
einfaches und schnelles Befüllen mit Feuerzuggas, Gehäuse aus Stahl, Fuß aus Kunststoff, einfach zu bedienen, mit Kindersicherung, verschleißfreie Piezo-Zündung, Flamme einstellbar, Flamme bis ca. 1450 °C

for Crème Brulée, caramelizing all kinds of food
easy and quick refill with lighter gas, body made of steel, easy to use, child proof safety lock system, self-igniting Piezo Ignition, safety adjustable flame, flame up to 1450 °C

#	↑ mm	Ø mm	
<input checked="" type="checkbox"/> 153090	165	45	1
<input checked="" type="checkbox"/> 153091	151	32	1



Art. 153090



Art. 153091



1

DE	KARAMELLISIERER / GASBRENNER-AUFSATZ
GB	SUGAR / BLOWTORCH / CAMELIZER
IT	CANNELLO
ES	FLAMBEADOR

für Crème Brulée, Karamellisieren von Speisen aller Art etc.
einfach zu bedienen, mit Kindersicherung, verschleißfreie Piezo-Zündung, Flamme einstellbar, Flamme bis ca. 1450 °C

for Crème Brulée, caramelizing all kinds of food
easy to use, child proof safety lock system, self-igniting Piezo Ignition, safety adjustable flame, flame up to 1450 °C

#	↔ mm	
<input checked="" type="checkbox"/> 153092	155	1



NEW

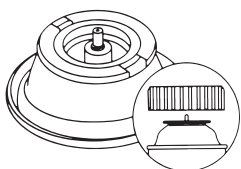

i direkter Anschluss an handelsübliche Gaskartuschen mit EU-Schraubgewinde „UNEF 7/16“ (Typ D) / Direct connection to standard gas cartridges with EU screw thread „UNEF 7/16“ (Type D)



Anwendungsbeispiel / example of use

DE	STABMIXER
GB	BLENDER
IT	MIXER
ES	MEZCLADOR



- Professionelle Qualität
 - Gehäuse aus stabilem Kunststoff
 - Rührstab und Messer aus Edelstahl
 - Leicht zu reinigen
 - Luftgekühlter Motor
 - Für die Zubereitung von Eis, Suppen, Musen, Soßen, Füllungen, Mayonnaise, etc.
- Professional quality
 - Housing made of sturdy plastic
 - Stainless steel rod and knife
 - Easy to clean
 - Air-cooled motor
 - For the preparation of ice cream, soups, muses, sauces, fillings, mayonnaise, etc.



Art. 153600 + Stab / blender





Art. 153610



Art. 153620

#	CE	153610	153620	153600
		MIX 250 S mit Mixstab / with blender	MIX 250 VSS mit Mixstab und Schneebesen / with blender and whisk	MIX 400 V Motorblock / motor
		250 W	250 W	400 W
		230 V 50–60 Hz	230 V 50–60 Hz	230 V 50–60 Hz
Geschwindigkeit einstellbar Variable speed		nein / no	ja / yes	ja / yes
Umdrehungen / min. RPIM		15.000	2.500 – 15.000	2.000 – 15.000
 l		20	20	50
Ø mm		75	75	100
 mm 		285	285	350
 mm 		270	290 / 270	–
 kg		1,0	1,0	2,1



Zubehör für MIX 400 V / #	153601	153602	153603	153604
	ST30 Rührstab / blender	ST40 Rührstab / blender	ST50 Rührstab / blender	SB33 Schneebesen / whisk
Ø mm	100	100	100	120
 mm	340	440	540	330
 kg	0,9	1,0	1,2	1,0



Art.-Nr. 152400

DE	HEBEL-DOSIERSPENDER
GB	LEVER SAUCE DISPENSERS
IT	DOSATORI PER CREME
ES	DOSIFICADOR

- Hebelbedienung
- Auslauf schwenkbar
- Behälter aus Edelstahl 18/10
- Dosierung einstellbar / 40 ml
- Antitropftülle
- Lever operation
- Container made of stainless steel 18/10
- Dosage adjustable / 40 ml
- Dripless valve

#	↔ mm	Ø mm	📦 l	🛒
152400	183 x 161 x 400	180	5,0	1
152401	405 x 205 x 421	180	2 x 5,0	1
152402	605 x 205 x 421	180	3 x 5,0	1
152450	260 x 240 x 408	260	10,0	1



Art.-Nr. 152450



Art.-Nr. 152401



Art.-Nr. 152402



DE	GEBÄCKFÜLLER
GB	CREAM DISPENSER
IT	DOSATORE PER CREME
ES	DOSIFICADOR DE PORCIONES

Speziell für Krapfen, Croissants und andere Gebäckarten.

- mit Hebelbedienung
- zylindrischer Edelstahl-Behälter 18/10 mit Klammern
- Dosierung einstellbar / 40 ml
- leichte Reinigung

For filling Berliner, croissants and other pastries

- with lever
- Cylindrical container made of stainless steel 18/10
- Dosage adjustable / 40 ml
- Easy cleaning

#	↔ mm	Ø mm	📦 l	🛒
152480	183 x 160 x 463	180	5,0	1
152481	183 x 160 x 463	180	4,5	1



DE	HEBEL-DOSIERSPENDER
GB	LEVER SAUCE DISPENSERS
IT	DOSATORI PER CREME
ES	DOSIFICADOR

- Hebelbedienung
- Auslauf schwenkbar
- **Ohne** GN-Behälter aus Edelstahl
- Geeignet für Behälter mit Tiefe 200 mm
- Dosierung einstellbar / 40 ml
- Antitropftülle
- Lever operation
- Drain totable
- **Without** GN container
- Suitable for containers with a depth of 200 mm
- Dosage adjustable / 40 ml
- Dripless valve

#	↔ mm	↑ mm	GN	
152413	183 x 330	365	1/3	1
152414	270 x 168	350	1/4	1
152416	183 x 168	350	1/6	1
152417	270 x 330	380	1/2	1



Art. 152416

1

Anwendungsbeispiele



Art. 152417



Art. 152413



Art. 152414

DE	DOSIERER FÜR BROTAUFSTRICH
GB	CREAM DISPENSER
IT	DOSATORE PER CREME
ES	DOSIFICADOR DE PORCIONES

- Passend für ca. 3 kg Eimer
Brottaufstrich (Nuss-Nougat-Creme)
- gebogen 180°, Edelstahl
 - 1-teilig mit Hebelbedienung
 - Auslauf schwenkbar
 - inklusive separater Dosiertülle
 - Dosierung einstellbar (35 ml)
 - leichte Reinigung

- Suitable for approx. 3 kg buckets
Sandwich spread (Nut Nougat Cream)
- curved 180°, stainless steel
 - 1-part with lever operation
 - outlet can be swivelled
 - including separate dosing spout
 - Adjustable dosage (35 ml)
 - easy cleaning

#	↑ mm	Ø mm	 l	
152482	380	260	3,0	1



Anwendungsbeispiel



DE	FLASCHENWÄRMER, ELEKTRISCH
GB	BOTTLE WARMER, ELECTRIC
IT	SCALDABIBERONONCHETTO ELETTRICO
ES	CALIENTABIBERONES ELÉCTRICO

- Außengehäuse Edelstahl
 - Temperatur stufenlos regelbar (40 – 90°C)
 - Kein Wasserbad – Temperatureaustausch erfolgt über Direktkontakt / Luft
 - Geringer Energieverbrauch
 - Inklusive Quetschflasche (470 ml) aus PP
 - Öffnungsdurchmesser: 86 mm
 - Öffnungstiefe: 195 mm
- Outer casing stainless steel
 - Temperature infinitely variable (40 – 90°C)
 - No water bath - temperature exchange via direct contact / air
 - Low energy consumption
 - Including squeeze bottle (470 ml) made of PP
 - Opening diameter: 86 mm
 - Opening depth: 195 mm



Art.-Nr. 150620



Art.-Nr. 150630



Art.-Nr. 150635

#	CE	150620	150630	150635
		Flaschenwärmer 1-fach	Flaschenwärmer 2-fach	Flaschenwärmer 3-fach
		Aussengehäuse Edelstahl	Aussengehäuse Edelstahl	Aussengehäuse Edelstahl
Zubehör		Quetschflasche 1 x 470 ml	Quetschflasche 2 x 470 ml	Quetschflasche 3 x 470 ml
→ mm		210	305	445
↓ mm		165	165	165
↑ mm		330	330	330
⚡		200 W 50 / 60 Hz / 230 Volt	400 W 50 / 60 Hz / 230 Volt	600 W 50 / 60 Hz / 230 Volt
°C		40° bis 90°C	40° bis 90°C	40° bis 90°C



DE	QUETSCHFLASCHE
GB	SQUEEZE DISPENSER
IT	SPREMERE BOTTIGLIA
ES	DISPENSADOR A PRESIÓN

Material: Polypropylen, transparent

Made of polypropylene, transparent

#	Öffnung / mouth	↑ mm	⚖ g	Ø mm	🗑 ml	🛒	
150625	1	281	85	80	950	1	
150621	3	291	74	80	950	1	

1

DE	WARMHALTEGERÄT MIT HEBELBEDIENUNG
GB	HEATED SAUCE DISPENSER
IT	DOSATORE TEMPERATO PER CREME
ES	DOSIFICADOR DE CALENTADORES

- Speziell für Kuvertüre, Suppen, Saucen und Dips
- Beheiztes Warmhaltegerät mit Hebelbedienung
 - Thermostat stufenlos einstellbar von 0 – 120 °C
 - Anzeige mit Kontrollleuchte
 - Leistung: 230 V, 50 Hz
 - Dosierung: 40 ml
 - Antitropftülle
- For filling couverture, soups, sauces and dips
- Heated container with lever
 - Temperature adjustable: 0 – 120 °C
 - Display with control light
 - Power: 230 V, 50 Hz
 - Dosage: 40 ml
 - Dripless valve
- Attention: Waterbath function**

#	↔ mm	Ø mm	l	🛒
152470	183 x 161 x 624	180	3,0	1



DE	GEBÄCKFÜLLER – WARMHALTEGERÄT MIT HEBELBEDIENUNG
GB	CREAM DISPENSER
IT	DOSATORE TEMPERATO PER CREME
ES	DOSIFICADOR DE CALENTADORES

- Speziell für Kuvertüre, Schokolade, Nougatcreme, Vanillecreme
- Beheiztes Warmhaltegerät mit Hebelbedienung
 - Thermostat stufenlos einstellbar von 0 – 120 °C
 - Anzeige mit Kontrollleuchte
 - Leistung: 230 V, 50 Hz
 - Dosierung: 40 ml
- Especially for couverture, chocolate, nougat cream, vanilla cream
- Heated container with lever
 - Temperature adjustable: 0 – 120 °C
 - Display with control light
 - Power: 230 V, 50 Hz
 - Dosage: 40 ml
 - Dripless valve
- Attention: Waterbath function**

NEW

#	↔ mm	Ø mm	l	🛒
152460	183 x 161 x 624	180	3,0	1



DE	DRUCKKNOPF-DOSIERSPENDER MIT GN-BEHÄLTER
GB	PUMP DISPENSERS WITH GN-CONTAINER
IT	DOSATORI PER CREME CON CONTENITORE GN
ES	DOSIFICADOR CON GN CONTENEDORES

- GN 1/6-Behälter, Material: Edelstahl
- Druckknopf-Bedienung (Edelstahl)
- Dosierung einstellbar / 30 ml
- 1/6 GN container made of stainless steel
- Push-button (stainless steel)
- Dosage adjustable / 30 ml

#	↔ mm	📏 l	🛒
152410 ●	178 x 166 x 323	3,0	1
152541 ○	178 x 166 x 323	3,0	1
152542 ●	178 x 166 x 323	3,0	1
152411	340 x 185 x 345	2 x 3,0	1
152412	504 x 185 x 345	3 x 3,0	1



Art. 152410



Art. 152411



Art. 152412

DE	DRUCKKNOPF-DOSIERSPENDER
GB	PUMP DISPENSERS
IT	DOSATORI PER CREME
ES	DOSIFICADOR

- Druckknopf-Bedienung (Edelstahl)
- Dosierung einstellbar / 30 ml
- Ø Behälter: 107 mm
- Push-button (stainless steel)
- Dosage adjustable / 30 ml
- Ø container: 107 mm

#	↔ mm	📏 l	🛒
152420 ●	107 x 107 x 358	2,25	1
152543 ○	107 x 107 x 358	2,25	1
152544 ●	107 x 107 x 358	2,25	1
152421	294 x 147 x 378	2 x 2,25	1
152422	442 x 147 x 378	3 x 2,25	1



Art. 152420



Art. 152421



Art. 152422

DE	DRUCKKNOPF-DOSIERSPENDER MIT SICHTFENSTER
GB	PUMP DISPENSERS
IT	DOSATORI PER CREME
ES	DOSIFICADOR

- zylindrischer Glasbehälter mit Edelstahlhülle
- Druckknopf-Bedienung (Kunststoff)
- Ø Behälter: 98 mm
- Cylindrical container made of stainless steel and glass
- Push-button (plastic)
- Ø container: 98 mm

#	↔ mm	📦 l	🛒
152430 ●	98 x 98 x 440	2,0	1
152545 ○	98 x 98 x 440	2,0	1
152547 ●	98 x 98 x 440	2,0	1
152431	293 x 147 x 465	2 x 2,0	1
152432	443 x 147 x 465	3 x 2,0	1



Art.-Nr. 152430



Art.-Nr. 152431



Art.-Nr. 152432

DE	DOSIERSYSTEM
GB	SAUCE DISPENSER
IT	DOSATORE
ES	DOSIFICACIÓN

- Polypropylen, zur Befestigung am Bügel, Behälter inklusive Einhand-Dosierspender; für alle Arten von Saucen, Senf, Ketchup, Mayonnaise
- Polypropylene, bracket fixing, container including one-hand dispensing device; for all kinds of sauces, mustard, ketchup, mayonnaise

#	↔ mm	📦 l	🛒
152970	170 x 170 x 330 mm	5,5	1

#	Zubehör / accessories	🛒
152971	Aufhängekette /Chain	1
152972	Wandhaken / Wall hook	1





DE HEBEL-DOSIERSPENDER
 GB LEVER SAUCE DISPENSER
 IT DOSATORE PER CREME
 ES DOSIFICADOR



- Inklusive PP-Behälter
- Hebelbedienung
- Auslauf schwenkbar
- Dosierung einstellbar / 40 ml
- Antitropftülle
- Included PP-Container
- Lever operation
- Adjustable pump
- Dosage adjustable / 40 ml
- Dripless valve

#	↑ mm	Ø mm	ml	📦 I	🛒
152490	440	250	40	10	1
152492	380	275	40	5	1



DE DRUCKKNOPF-DOSIERSPENDER
 GB PUMP DISPENSER
 IT DOSATORE PER CREME
 ES DOSIFICADOR

- Inklusive PP-Behälter
- Druckknopf-Bedienung
- Dosierung einstellbar
- Included PP-Container
- Push-button (stainless steel)
- Dosage adjustable

#	↑ mm	Ø mm	ml	📦 I	🛒
152495	400	265	30	10	1
152496	340	225	30	5	1



DE EIMER
 GB BUCKET
 IT SECCHI
 ES CUBO

#	📦 I	🛒
152491	10	1
152497	5	1



Anwendungsbeispiel:
 Lieferung ohne Behälter

example: delivery without container

DE DECKEL INKLUSIVE PUMPE
 GB SOUCE DISPENSER PUMP INCLUDING COVER
 IT COPERCHIO CON POMPA
 ES CUBIR CON LA BOMBA

- Deckel aus Aluminium
- Für 10 kg und 12 kg Eimer
- Inklusive Pumpe
- Cover made of aluminum
- For 10 kg and 12 kg buckets
- Including pump

#	Ø mm	ml	🛒
154702	280	30	1

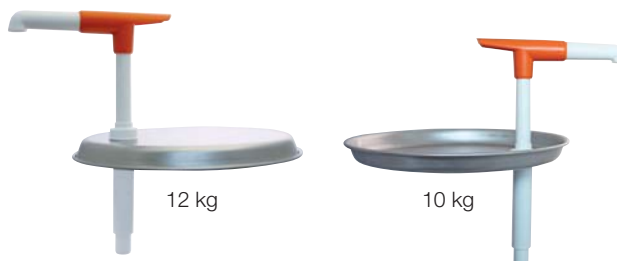

DE	DRUCKKNOPF-DOSIERSPENDER
GB	PUMP DISPENSERS
IT	DOSATORE PER CREME
ES	DOSIFICADOR

- Druckknopf-Bedienung
- Schwenkbar
- Spülmaschinengeeignet
- Push-button
- Traversable
- Dishwasher safe

Deckel: Kunststoff (PE)

Lid made of PE

#	↗ mm	→ mm	↑ mm	♻️ l	🛒
154710	120	155	150*	2,0	1
154711	120	155	210*	3,0	1
154712	120	155	340*	5,0	1

* ohne Pumpe / without pump



Deckel: Edelstahl

Lid made of stainless steel

#	↗ mm	→ mm	↑ mm	♻️ l	🛒
154720	120	155	150*	2,0	1
154721	120	155	210*	3,0	1
154722	120	155	340*	5,0	1

* ohne Pumpe / without pump



DE	DOSIERSPENDER
GB	DISPENSERS
IT	DOSATORI
ES	DISPENSADORES











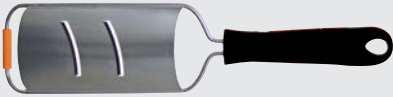

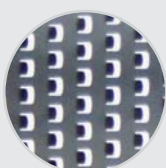

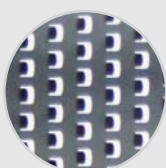
- Druckknopf-Bedienung, schwenkbar
- Spülmaschinengeeignet
- Hub: 30 ml
- Unterbehälter: PS, transparent
- Push-button, traversable
- Dishwasher safe
- Dosage: 30 ml
- Container: PS, transparent

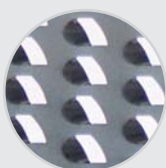

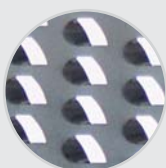
#		♻️ ml	🛒
152923	rund / round	1500	1
152924	rund / round	2200	1
152933	quadratisch / square	1450	1
152934	quadratisch / square	2000	1

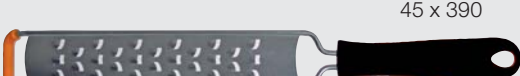

DE	REIBEN
GB	GRATERS
IT	GRATTUGIE
ES	RALLADOR

		#		↔ mm	
1. Hobel / shaver 	Schokolade, harter Käse, Gurken, Knoblauch, Ingwer, Trüffel, Butter / Chocolate, hard cheeses, cucumbers, garlic, ginger, truffles, butter	292000		75 x 320	1
		<input checked="" type="checkbox"/>			
2. fein / fine 	Zitrusfrüchte, Gewürze / Citrus zest, spices	292001		75 x 320	1
		<input checked="" type="checkbox"/>			
3. grob / coarse 	Käse, Karotten, Kokos, Schokolade / Hard cheeses, carrots, coconut, chocolate	292002		45 x 390	1
		<input checked="" type="checkbox"/>			
3. grob / coarse 	Käse, Karotten, Kokos, Schokolade / Hard cheeses, carrots, coconut, chocolate	292003		75 x 320	1
		<input checked="" type="checkbox"/>			
4. sehr grob / extra coarse 	Zucchini, Kartoffeln, weicher Käse, Karotten, Äpfel, Kohl / Zucchini, potatoes, soft cheeses, carrots, apples, cabbage	292004		45 x 390	1
		<input checked="" type="checkbox"/>			
4. sehr grob / extra coarse 	Zucchini, Kartoffeln, weicher Käse, Karotten, Äpfel, Kohl / Zucchini, potatoes, soft cheeses, carrots, apples, cabbage	292005		75 x 320	1
		<input checked="" type="checkbox"/>			
5. Stern / star 	harter Käse, Zitrusfrüchte, Knoblauch, Muskatnuss / hard cheeses, citrus zest, garlic, nutmeg	292006		45 x 390	1
		<input checked="" type="checkbox"/>			
5. Stern / star 	harter Käse, Zitrusfrüchte, Knoblauch, Muskatnuss / hard cheeses, citrus zest, garlic, nutmeg	292007		75 x 320	1
		<input checked="" type="checkbox"/>			
		292008		45 x 390	1
		<input checked="" type="checkbox"/>			





DE	UNIVERSAL-REIBE
GB	GRATER
IT	GRATUGIA UNIVERSALE
ES	RALLADOR UNIVERSAL

Material: Edelstahl, Griff ABS,
4-seitig

made of stainless steel, handle made of ABS,
4-way

#	↗ mm	→ mm	↑ mm	
151140	220	90	70	1



DE	GEMÜSEHOBEL (MANDOLINE)
GB	SLICER FOR VEGETABLES
IT	AFFETTATRICE PER VERDURE
ES	CORTADORA

Material: Edelstahl, inklusive 3 Messer

made of stainless steel, including 3 cutting
blade units

#	↗ mm	kg	
151195	400	1,5	1



DE	PASTETENAUSSTECHER
GB	CUTTERS FOR PATE
IT	TAGLIAPASTA PER PATÈ
ES	CORTADOR PARA PATÉ

Material: Edelstahl; Materialstärke: 0,4 mm
Höhe: 50 mm

made of stainless steel; thickness: 0,4 mm
height: 50 mm

#	↔ mm	⊓ mm	
199892	66	40	1
199893	Pastetenhalter/mould	40	1
199894	73	47	1
199895	Pastetenhalter/mould	45	1



DE	CREME-FORMEN
GB	YULE LOG MOULDS
IT	STAMPI PER TRONCO, TONDI
ES	MOLDES MEDIA CAÑA PARA CREMA REDONDOS

Material: Edelstahl

made of stainless steel

Ausführung: geschlossene Form

model: self-contained

Design: rund

design: round



#	↗ mm	→ mm	↑ mm		
193030	500	50	37	1	
193031	500	60	45	1	
193032	500	70	50	1	
193033	500	80	62	1	

Material: Edelstahl

made of stainless steel

Ausführung: offene Form

model: removable ends

Design: rund

design: round



#	↗ mm	→ mm	↑ mm		
193040	500	85	70	1	

Design: Trapez

design: trapezoidal



#	↗ mm	→ mm	↑ mm		
193041	600	90	75	1	

DE	DARIOLFORMEN
GB	CREAM TART MOULDS (DARIOL MOULDS)
IT	STAMPI PER DARIOLE
ES	MOLDES PARA DARIOLES

Material: Edelstahl

made of stainless steel



#	↑ Ø mm	↓ Ø mm		↑ mm		
199409	45	35	45	40	1	
199410	55	40	70	50	1	
199411	65	45	100	60	1	
199412	85	60	150	80	1	

Material: Aluminium

made of aluminum



#	↑ Ø mm	↓ Ø mm		↑ mm		
997950	50	40	70	50	6	
997951	60	45	110	52	6	
997952	70	55	150	60	6	
997953	80	60	190	75	6	

DE	SCHAUMSPEISERINGE-SET
GB	MOUSSE-FRAME-SET
IT	SET CORNICI PER DOLCI
ES	JUEGO DE CUADRADOS PARA POSTRES

Material: Edelstahl
3 Formen + 1 Drücker

stainless steel
3 frames + 1 pusher

#		↔ mm	↑ mm	
166500	Quadrat / square	55	45	1 Set
166501	Dreieck / triangle	55	45	1 Set
166502	Sechseck / hexagon	75	45	1 Set
166503	Rund / round	70	45	1 Set
166504	Herz / heart	75	45	1 Set
166505	Oval / oval	78	45	1 Set
166506	Rechteck abgerundet / rectangular curved	68	45	1 Set
166507	Dreieck abgerundet / triangular curved	65	45	1 Set
166508	quadrat abgerundet / square curved	65	45	1 Set
166509	Tropfen / drop	73	45	1 Set

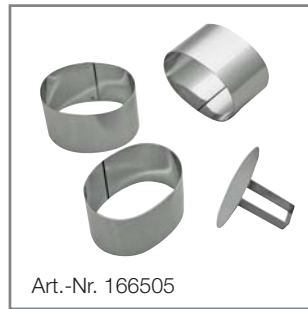
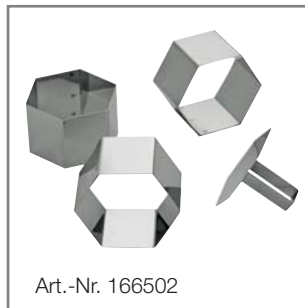

DE	DESSERT - / TORTENRINGE
GB	DESSERT / TART RINGS
IT	ANELLI PER TORTE E DESSERT
ES	AROS PARA TARTAS

Material: Edelstahl

made of stainless steel

#		↔ mm	↑ mm	
155060	Achteck / octagon	∅: 160	50	5
155100	Sechseck / hexagon	∅: 160	50	5
155110	Sechseck / hexagon	∅: 180	50	5
155120	Sechseck / hexagon	∅: 200	50	5
155200	Herz / heart	∅: 180	50	5
155210	Herz / heart	∅: 200	50	5
155220	Herz / heart	∅: 230	50	5
155300	Dreieck / triangle	160	50	5
155310	Dreieck / triangle	180	50	5
155320	Dreieck / triangle	200	50	5

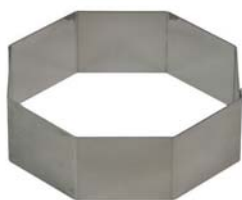

Art.-Nr. 155060



Art.-Nr. 155100 bis 155120

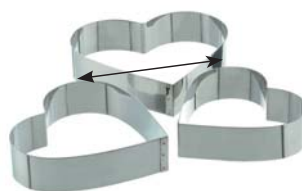

Art.-Nr. 155200 bis 155220



Art.-Nr. 155300 bis 155320

#		↗ mm	↑ mm	⏊ mm	
155330	Tropfen / tear-drop	160	50	1,2	5
155331	Tropfen / tear-drop	180	50	1,2	5
155332	Tropfen / tear-drop	200	50	1,2	5
155340	Dreieck, gewölbt / triangle, convex	160	50	1,2	5
155341	Dreieck, gewölbt / triangle, convex	180	50	1,2	5
155342	Dreieck, gewölbt / triangle, convex	200	50	1,2	5
155350	Viereck, gewölbt / square, convex	140	50	1,0	5
155351	Viereck, gewölbt / square, convex	160	50	1,0	5
155352	Viereck, gewölbt / square, convex	180	50	1,0	5



Art.-Nr. 155330 bis 155332



Art.-Nr. 155340 bis 155342



Art.-Nr. 155350 bis 155352

DE	DESSERTRING
GB	DESSERT RING
IT	ANELLI PER DOLCI
ES	ARO PARA POSTRES

NICHT zum Backen geeignet!
NOT for baking!

1

Material: PS, Farbe Elfenbein
Nicht zum Backen im Ofen geeignet!

made of PS, ivory
Not suitable for baking in ovens!



#	Ø mm	↑ mm	
200950	75	30	20

Material: Reinaluminium, nahtgeschweißt, extra stark

made of pure aluminum, welded seam, extra strong



#	Ø mm	↑ mm	∩ mm	
156075	75	30	2	5
156076	75	40	2	5

“MINI”
Material: Edelstahl; Materialstärke: 0,8 mm

“MINI”
made of stainless steel; thickness: 0,8 mm

#		↔ mm	↑ mm	
155450	Rund / round	Ø 70	45	1
155451	Oval / oval	74 x 56	45	1
155452	Tropfen / drop	77 x 54	45	1
155453	Dreieck / triangle	68	45	1
155454	Herz / heart	55 x 67	45	1
155455	Sechseck / hexagon	54	45	1
155456	Quadrat / square	54	45	1





DE	VORLEGEBESTECK HITZEBESTÄNDIG
GB	CUTLERY, HEAT-RESISTANT
IT	POSATERIA RESISTENTE AL CALORE
ES	CUBERTERÍA REFRACTARIA

Material: PPA, schwarz

Made of PPA, black

Hitzebeständig bis + 270 °C (*+ 220 °C)

Heat resistant up to + 270 °C (*+ 220 °C)

#		↔ mm		
<input checked="" type="checkbox"/>	172460	Bratgutwender / slotted turner	310 x 85	1
<input checked="" type="checkbox"/>	172461	Suppenkelle / soup ladle	300 x 90 x 35	1
<input checked="" type="checkbox"/>	172462	Spaghettilöffel / spaghetti spoon	300 x 72	1
<input checked="" type="checkbox"/>	172463	Schaumlöffel / skimmer	325 x 108	1
<input checked="" type="checkbox"/>	172464	Servierlöffel / serving spoon	300 x 65	1
<input checked="" type="checkbox"/>	172465	Kochlöffel / cooking spoon	300 x 62	1
<input checked="" type="checkbox"/>	172466	Crêpe-Spachtel* / crepe spatula*	320 x 36	1
<input checked="" type="checkbox"/>	172370	Pinzette* / kitchen pincers*	305 x 18	1
<input checked="" type="checkbox"/>	172371	Fischzange* / fish tong*	27,7 x 15,0	1

* Hitzebeständig bis + 220 °C / Heat resistant up to + 220 °C



DE	FLEISCHGABEL UND NUDELGREIFER
GB	TWO TIN FORK AND PASTA LADLE
IT	FORCHETTONI PER CARNE E CUCCHIAI PER PASTA
ES	TENEDOR MONOBLOC

Material: Edelstahl, fugenlos

made of stainless steel

#	↗ mm	↔ mm		
<input checked="" type="checkbox"/>	198060	340	1	
<input checked="" type="checkbox"/>	198061	315	75	1

DE	SCHÖPFER
GB	LADLES
IT	CUCCHIAIONI IN UNIPEZZO
ES	CACILLOS MONOBLOC

Material: Edelstahl, fugenlos

made of stainless steel

	#	Nr. /no.	↗ mm	↔ mm	
<input checked="" type="checkbox"/>	198021	1	330	65 x 90	1
<input checked="" type="checkbox"/>	198022	2	330	65 x 90	1
<input checked="" type="checkbox"/>	198030	3	400	65 x 90	1
<input checked="" type="checkbox"/>	198032	4	450	65 x 90	1
<input checked="" type="checkbox"/>	198033	5	450	65 x 90	1



DE	WENDER
GB	TURNERS
IT	PALETTE IN UNIPEZZO
ES	ESPÁTULAS MONOBLOC

Material: Edelstahl, fugenlos

made of stainless steel

	#	Nr. /no.	↗ mm	↔ mm	
<input checked="" type="checkbox"/>	198040	1	360	80 x 95	1
<input checked="" type="checkbox"/>	198041	2	445	100 x 100	1
<input checked="" type="checkbox"/>	198042	3	470	100 x 100	1
<input checked="" type="checkbox"/>	198043	4	470	100 x 100	1



DE	SAUCEN-LÖFFEL
GB	BASTING SPOONS
IT	MESTOLI IN UNIPEZZO
ES	CAZILLOS PARA VERSAR MONOBLOC

Material: Edelstahl, fugenlos

made of stainless steel

	#	↗ mm	↔ mm	
<input checked="" type="checkbox"/>	198050	300	Ø 80	1
<input checked="" type="checkbox"/>	198051	310	70 x 110	1





DE	SCHÖPFER
GB	LADLES
IT	MESTOLI IN UNIPEZZO
ES	CACILLOS MONOBLOC

Material: Edelstahl, fugenlos

made of stainless steel

	#	Ø mm	↗ mm		
<input checked="" type="checkbox"/>	198801	65	340	0,08	1
<input checked="" type="checkbox"/>	198802	80	380	0,12	1
<input checked="" type="checkbox"/>	198803	90	420	0,20	1
<input checked="" type="checkbox"/>	198804	100	450	0,25	1
<input checked="" type="checkbox"/>	198805	120	500	0,50	1
<input checked="" type="checkbox"/>	198806	140	530	0,75	1
<input checked="" type="checkbox"/>	198807	160	580	1,00	1
<input checked="" type="checkbox"/>	198808	180	610	1,50	1



DE	SCHAUMLÖFFEL
GB	SKIMMERS
IT	SCHIUMAROLE IN UNIPEZZO
ES	ESPUMADERA MONOBLOC

Material: Edelstahl, fugenlos

made of stainless steel

	#	Ø mm	↗ mm	
<input checked="" type="checkbox"/>	198820	80	340	1
<input checked="" type="checkbox"/>	198821	100	390	1
<input checked="" type="checkbox"/>	198822	120	450	1
<input checked="" type="checkbox"/>	198823	140	500	1
<input checked="" type="checkbox"/>	198824	160	560	1
<input checked="" type="checkbox"/>	198825	180	580	1



DE	BACK- UND SCHAUMLÖFFEL
GB	SKIMMERS
IT	SCHIUMAROLE A FILO
ES	ESPUMADERA A FILO

Material: Edelstahl

made of stainless steel

	#	Ø mm	
<input checked="" type="checkbox"/>	198880	160	1
<input checked="" type="checkbox"/>	198881	200	1
<input checked="" type="checkbox"/>	198882	240	1
<input checked="" type="checkbox"/>	198883	280	1



DE	GOURMET-PASSIERSIEBE
GB	GOURMET BOUILLON-SIEVES
IT	COLINI PASSABRODO
ES	COLADORES PARA PASAR CALDO

zum Abseihen feiner Saucen, Dämpfen, Einmachen etc.. Material: feinmaschiges Nylonnetz, spülmaschinengeeignet, hitzebeständig bis +150 °C

kitchen net for straining, steaming, jam making etc.

Made of fine woven nylon cloth, dishwasher proof, heatresistant up to +150 °C

	#	Ø mm	
<input checked="" type="checkbox"/>	199095	200	1
<input checked="" type="checkbox"/>	199096	240	1

1

DE	PASSIERSIEBE
GB	GOURMET SIEVES
IT	COLINI PASSABRODO
ES	COLADORES PARA PASAR CALDO

Material: Edelstahlgriff und Auflagehaken, **extra breiter Rand** made of stainless steel, with handle and hook, **extra-wide frame**



	#	Ø mm	⊞ mm	🛒
<input checked="" type="checkbox"/>	199328	180	0,84	1

Material: Edelstahlgriff und Auflagehaken made of stainless steel, with handle and hooks



	#	Ø mm	⊞ mm	🛒
<input checked="" type="checkbox"/>	199329	220	1,5	1
<input checked="" type="checkbox"/>	199330	260	1,5	1
<input checked="" type="checkbox"/>	199331	300	1,5	1



Material: Edelstahlgriff und Auflagehaken made of stainless steel, with handle and hooks



	#	Ø mm	🛒
<input checked="" type="checkbox"/>	199370	160	1
<input checked="" type="checkbox"/>	199371	180	1
<input checked="" type="checkbox"/>	199372	200	1
<input checked="" type="checkbox"/>	199373	220	1
<input checked="" type="checkbox"/>	199374	240	1
<input checked="" type="checkbox"/>	199375	260	1



DE	GROSSKÜCHENSIEBE
GB	BOWL STRAINERS
IT	COLAPASTA RINFORZATI
ES	COLADOR REFORZADO

Material: Edelstahl mit Schutzbügel made of stainless steel, with guard



	#	Ø mm	🛒
<input checked="" type="checkbox"/>	198840	260	1
	198841	Ersatzsieb / spare strainer insert	1





DE	SPITZSIEBE
GB	CONICAL STRAINERS
IT	CORNETTI CINESI
ES	COLADORES CHINOS

Material: Edelstahl made of stainless steel

#	Ø mm		
<input checked="" type="checkbox"/> 199321	230	1	



Material: Edelstahl made of stainless steel

#	Ø mm		
<input checked="" type="checkbox"/> 199380	100	1	
<input checked="" type="checkbox"/> 199381	140	1	
<input checked="" type="checkbox"/> 199382	180	1	
<input checked="" type="checkbox"/> 199383	230	1	
<input checked="" type="checkbox"/> 199384	230 extra fein / extra fine	1	



DE	GAZE-SIEBE
GB	CONICAL STRAINERS
IT	CORNETTI CINESE A RETE
ES	COLADORES CHINO A RED

Material: Edelstahl made of stainless steel

#	Ø mm		
<input checked="" type="checkbox"/> 198860	210	1	
<input checked="" type="checkbox"/> 198861	250	1	



DE	KÜCHENSIEBE
GB	SAUCE STRAINERS
IT	COLATUTTI
ES	COLADORES

Material: Edelstahl made of stainless steel

#	Ø mm		
<input checked="" type="checkbox"/> 198870	80	1	
<input checked="" type="checkbox"/> 198871	100	1	
<input checked="" type="checkbox"/> 198872	120	1	
<input checked="" type="checkbox"/> 198873	150	1	
<input checked="" type="checkbox"/> 198874	180	1	
<input checked="" type="checkbox"/> 198875	200	1	

DE	STREUER
GB	SHAKER
IT	SPARGITORE
ES	DISPENSADOR

Material: Aluminium, mit Schraubdeckel made of aluminum, with screw cap

#	Ø mm	↑ mm	
198890	80	190	1



1

DE	POMMESFRITES-ABTROPFSCHÜSSEL
GB	FRENCH FRIES COLANDER
IT	BACINELLA PER DRENAGGIO DI PATATINE FRITTE
ES	COLADOR PATATAS FRITAS

Material: Edelstahl, Sammelbehälter abnehmbar, mit Griffen made of stainless steel, detachable drip tray, with handles

#	Ø mm	
198891	400	1



DE	KARTOFFELSTAMPFER
GB	POTATO MASHER
IT	PRESSAPATATE
ES	PRENSADOR DE PATATAS

Material: Edelstahl, extra schwere Ausführung made of stainless steel, heavy quality

#	↗ mm	
198892	580	1



DE	RÜHRSPATELN
GB	PADDELS
IT	SPATOLE
ES	ESPÁTOLA



* Sperrgut

Material: Polypropylen, weiß, hitzebeständig bis 100°C Made of polypropylene, white, heat resistant up to 100° C
Perforiert perforated

#	↗ mm	
228128	1000	1
228129 *	1200	1





DE	BESTECKKASTEN
GB	CUTLERY TRAY
IT	PORTA POSATE
ES	BANDEJA PORTA CUBIERTOS

Material: PE, grau, mit 4 Fächern made of polyethylene, colour grey, with 4 partitions

#	↗ mm	
250100	330 x 530 x 100	1

DE	ZETTELHALTER
GB	LABEL HOLDERS
IT	PORTA ETICHETTE
ES	PORTA-ETIQUETAS

aus eloxiertem Aluminium, für Wandbefestigung made of anodised aluminum, for wall mounting



#	↗ mm	
191011	500	1
191012	750	1
191013	1000	1

Material: Edelstahl made of stainless steel



#	↗ mm	→ mm	↑ mm	kg	
191120	625	15	95	0,76	1
191121	1000	15	95	1,40	1

DE	SPACHTELN
GB	SPATULAS
IT	SPATOLE TRIANGOLARI, MANIGLIA NERO, INOX
ES	ESPÁTULAS TRIANGULARES, MANGO NEGRO

Material: Edelstahl, Kunststoffgriff schwarz (PP) made of stainless steel, black plastic handle (PP)



#	→ mm	
<input checked="" type="checkbox"/> 200500	40	1
<input checked="" type="checkbox"/> 200501	60	1
<input checked="" type="checkbox"/> 200502	80	1
<input checked="" type="checkbox"/> 200503	100	1
<input checked="" type="checkbox"/> 200504	120	1

DE	QUETSCHFLASCHE
GB	SQUEEZE DISPENSER
IT	SPREMERE BOTTIGLIA
ES	DISPENSADOR A PRESIÓN

Material: Polypropylen

Made of polypropylene

#	Öffnung / mouth	↑ mm	g	Ø mm	ml	
150625	1 ○	281	85	80	950	1
150621	3 ○	291	74	80	950	1

200490	1 ○	195	30	52	250	1
200491	1 ○	240	42	62	500	1
200492	1 ○	265	61	72	750	1
200493	1 ●	240	42	62	500	1
200494	1 ●	265	61	72	750	1
200495	1 ●	240	42	62	500	1
200496	1 ●	265	61	72	750	1



Art. 150625

Art. 150621

1



DE	ZUCKERSTREUER
GB	SUGAR DISPENSERS
IT	SPARGIZUCCHERI
ES	DOSIFICADOR PARA AZÚCAR CON TAMIZ

Material: Edelstahl

made of stainless steel

#		↑ mm	Ø mm	mm	l	
199026	mit Sieb / with meshes	75	55	0,8	0,15	1
199027	mit Sieb / with meshes	90	65	0,8	0,25	1
199028	mit Sieb / with meshes	128	68	0,8	0,35	1

199059	kleine Lochung / small holes	75	55	1,5	0,15	1
199060	kleine Lochung / small holes	88	68	1,5	0,25	1
199061	kleine Lochung / small holes	128	68	1,5	0,35	1

199065	große Lochung / large holes	75	55	2,5	0,15	1
199063	große Lochung / large holes	90	65	2,5	0,25	1
199064	große Lochung / large holes	100	70	4,0	0,30	1





DE	FLASCHEN- UND DOSENÖFFNER
GB	BOTTLE AND CAN OPENER
IT	APRIBOTTIGLIE E APRISCATOLE
ES	ABREBOTTILLAS Y ABRELATAS

Material: verchromter Stahl, schwarzer Kunststoffgriff, leichte Ausführung
 made of chrome-plated steel black handle made of plastic

#		kg		
151190		0,25	1	



DE	PROFI-DOSENÖFFNER
GB	PROFESSIONAL CAN OPENERS
IT	APRISCATOLE INDUSTRIALI
ES	ABRELATAS INDUSTRIAL

Material: vernickelter Stahl oder Edelstahl
 made of nickel plated steel or stainless steel

#		mm	kg	
151170	vernickelt/nickel plated steel	600	2,5	1
151175	Edelstahl/stainless steel	600	2,5	1
151171	Ersatz-Messer/knife			1
151172	Zahnrad/gear wheel			1



DE	PENDELSCHÄLER
GB	SWIVEL PEELER
IT	PELATAPATE
ES	PELADOR

Material: Metall, Klinge rostfrei
 Made of metal, blade stainless steel

#	→ mm	↗ mm	
<input checked="" type="checkbox"/> 260868	50	157	1



DE	SPARSCHÄLER
GB	SPEED PEELER
IT	PELATAPATE
ES	PELADOR

Material: Edelstahl
 Made of stainless steel

#	→ mm	↗ mm	
<input checked="" type="checkbox"/> 260869	42	110	1

DE	SALATSCHLEUDER
GB	SALAD SPINNER
IT	CENTRIFUGA PER VERDURE
ES	SECADOR PARA VERDURAS

- Material: Polypropylen
- Deckel transparent
 - Für Salat, Obst und Gemüse
 - Filter abnehmbar

- Made of polypropylene
- Cover transparent
 - For salad, fruits and vegetables
 - Removable filter

#	↑ mm	Ø mm	🔄 l	🛒
290150	400	420	20	1



DE	TOMATENSCHNEIDE-GERÄT
GB	TOMATO SLICER
IT	AFFETTA POMODORI
ES	CORTA TOMATE

- Material: Edelstahl; Schnittbreite: 5,5 mm
- Einfache Bedienung
 - Leicht zu reinigen
 - Aus hochwertigem Edelstahl
 - Ergonomischer Hartkunststoff Griff
 - GummifüÙe für eine sichere Standfestigkeit

- Made of stainless steel; slices 5,5 mm
- Simple operation
 - Easy to clean
 - Made of premium stainless steel
 - Ergonomic handle made of plastic rubber feet for secure stability

#	↔ mm	🛒
151065	450 x 210 x 210	1
151066	Ersatzmesser / replacement blades	1





DE	BROT-/SANDWICH-SCHNEIDGERÄT
GB	BREAD/SANDWICH SLICER
IT	TAGLIA PANINI
ES	CORTADOR DE PAN

Material: Edelstahl
schneidet das Baguette in 2 Teile

made of stainless steel
cuts the baguette in two parts

#	↗ mm	→ mm	↑ mm	⚖ kg	🛒
153570	205	60	105	1,36	1



DE	EIERTEILER
GB	EGG SLICER
IT	TAGLIA UOVA
ES	CORTADOR DE HUEVOS

für runde und ovale Scheiben
Material: beschichtetes Aluminium, einzeln gespannte Drähte aus Edelstahl

for round and oval slices, made of coated aluminum, individually mounted wires made of stainless steel

#	↗ mm	→ mm	↑ mm	🛒
199361	130	82	25	1



DE	EIERSTÜCKLER
GB	EGG CUTTER
IT	TAGLIA UOVA
ES	CORTADOR DE HUEVOS

zum Teilen von harten gekochten Eiern in 6 gleiche Stücke. Material: beschichtetes Aluminium, Drähte aus Edelstahl

to divide hard boiled eggs into 6 equal parts, made of coated aluminum, wires made of stainless steel

#	↗ mm	→ mm	↑ mm	🛒
199362	180	65	25	1



DE	RADIESCHENVERZIERER
GB	RADISHES DECORATOR
IT	TAGLIA RAVANELLO
ES	CORTADOR RABANITO

Material: beschichtetes Aluminium, Drähte aus Edelstahl

made of coated aluminum, wires made of stainless steel

#	↗ mm	→ mm	↑ mm	🛒
199363	180	55	25	1

DE	APFELTEILER
GB	APPLE SLICER
IT	TRANCIA SPICCHI PER MELA
ES	CORTADOR DE MANZANAS

zum Teilen in 10 gleiche Stücke und Entfernen des Kerngehäuses. Material: Aluminium, beschichtet, Messer aus Edelstahl

cores the fruit and cuts it into 10 equal parts, made of coated aluminum, blades stainless steel

#	↔ mm	∅ mm	
199031	170	90	1



1

DE	APFEL AUSSTECHER
GB	APPLE CORER
IT	SVUOTA MELA
ES	SACA CORAZÓN DE MANZANAS

für schnelles Ausstechen des Kerngehäuses, Material: Edelstahl, Griff aus PP, schwarz

quick and clean coring, made of stainless steel, handle made of PP, black

#	↗ mm	∅ mm	
199032	200	20	1



DE	KNOBLAUCHPRESSE
GB	GARLIC PRESS
IT	SPREMIAGLIO
ES	PRESADOR DE AJO

Material: beschichtetes Aluminium

made of coated aluminum

#	↗ mm	→ mm	
199364	155	25	1



DE	OLIVENENTSTEINER
GB	OLIVE STONER
IT	SNOCCIOLATORE
ES	QUITA HUESO, ACEITUNA

für große und kleine Oliven
Material: beschichtetes Aluminium

usable for big and small olives
made of coated aluminum

#	↗ mm	
199365	185	1





DE RÜHRSCHÜSSELN
 GB MIXING BOWLS
 IT BACINELLE TONDE, POLIPROPILENE
 ES CALDEROS SEMIESFÉRICOS, PLÁSTICO



Material: PP, natur-weiß, bruchsicher und hygienisch, stapelbar, für Mikrowellengeräte geeignet

made of PP, natural white, break resistant, hygienic, stackable, suitable for microwave



#	l	Ø mm	↑ mm	
290000	1,0	190	79	1
290010	2,5	240	115	1
290020	4,5	280	135	1
290030	6,0	325	147	1
290040	9,0	360	165	1
290050	13,0	400	185	1

DE DECKEL
 GB LID
 IT COPERCHI
 ES TAPA

Material: PP

made of PP



#	für Art.Nr. / for Art.No.	Ø mm	
290070	290000 (1,0 l)	190	1
290071	290010 (2,5 l)	240	1
290072	290020 (4,5 l)	280	1
290073	290030 (6,0 l)	325	1
290074	290040 (9,0 l)	360	1
290075	290050 (13,0 l)	400	1

DE	FRÜCHTE ABLAUF-SET, RUND
GB	FRUIT STRAINER SET, ROUND
IT	SET PER SCOLARE LA FRUTTA
ES	BOL Y TAMIZ PARA FILTRAR LOS ZUMOS DE LAS FRUTAS

Material: PP, weiß, bruchstark und hygienisch, Sieb mit praktischem Griff, alle Komponenten einzeln erhältlich

made of PP, white, break resistant, hygienic, stackable, strainer with 2 handles, each part available separately

#		Ø mm	↓ ↑ l	🛒
290040	Schüssel/round Bowl	360	9,0	1
200022	Seiher/strainer	280		1



DE	SEIHER
GB	STRAINER
IT	COLAPASTA IN PLASTICA
ES	COLADOR, PLÁSTICO

Material: PP, weiß, 2 Muschelgriffe passende Schüssel Art-Nr. 221026+290040

made of polypropylene, with 2 shell shaped grips, corresponding bowl code 221026+290040

#	↑ Ø mm	↓ Ø mm	↑ mm	🛒
200022	360	280	185	1



DE	RÜHRSCHÜSSEL
GB	MIXING BOWL
IT	BACINELLE TONDE IN PLASTICA
ES	CALDEROS SEMIESFÉRICOS, PLÁSTICO

Material: ABS, weiß, inkl. Ausgießer und praktischem Handgriff, Ringfuß, antirutsch

made of ABS, white, incl. sprout and convenient handle, nonslip base

#		Ø mm	↓ ↑ l	🛒
290300	Schüssel/round Bowl	240	4,25	1



DE	KASSELLE
GB	SAUCEPAN
IT	CASSERUOLA IN POLIPROPILENE
ES	CACEROLA



Material: PP, weiß, mit geprägter Skala in Innenseite und zusätzl. blauem Skalendruck auf der Außenseite, bruchstark und hygienisch, für Mikrowellengeräte geeignet Volumen: 2,0 Liter

made of PP, with inside scale and blue stamped litre and ml scale outside, break resistant, suitable for microwave volume: 2,0 ltr.

#	↗ mm	Ø mm	↑ mm	🛒
290200	335	190	120	1



i Ausgießer beidseitig somit für Links- und Rechtshänder geeignet. / For right- and left handed.



Art. 200010 bis 200015

DE	MESSBECHER
GB	MEASURING CUPS
IT	CARAFFE GRADUATE
ES	JARRAS GRADUADAS, ASA CERRADA

Material: PP, Farbe natur, geprägte Skala und blauem Skalendruck, Liter- und Milliliter-Einteilung, bis 95°C erhitzen

made of PP, translucent, with stamped and blue printed litre and ml scale, temperature resistant up to 95°C

#		l	
206010	ohne Griff / without handle	0,12	10
200010	mit geschlossenem Griff / closed handle	0,25	25
200011	mit geschlossenem Griff / closed handle	0,5	16
200012	mit geschlossenem Griff / closed handle	1,0	12
200013	mit geschlossenem Griff / closed handle	2,0	12
200014	mit geschlossenem Griff / closed handle	3,0	10
200015	mit geschlossenem Griff / closed handle	5,0	5
206011	mit offenem Griff / open handle	0,5	16
206012	mit offenem Griff / open handle	1,0	12
206013	mit offenem Griff / open handle	2,0	12
206014	mit offenem Griff / open handle	3,0	10
206015	mit offenem Griff / open handle	5,0	5



Art. 206011 bis 206015



206010

DE	MESSBECHER-DECKEL
GB	MEASURING CUPS-LIDS
IT	COPERCHI
ES	TAPA



#	für Artikel / for article	
206112	200012 + 206012 / 1,0 l	32
206113	200013 + 206013 / 2,0 l	16

DE	MESSBECHER
GB	MEASURING CUPS
IT	CARAFFE GRADUATE, IMPILABILI
ES	JARRAS GRADUADAS, APILABLES

Material: PP, Farbe natur, mit offenem Griff, stapelbar, Liter- und Milliliter-Einteilung, bis 95°C erhitzen

made of PP, translucent, with open handle, stackable, with litre- and ml-scale, temperature resistant up to 95°C



#	l	
200149	0,5	10
200150	1,0	10
200170	2,0	10
200179	3,0	10

DE	RÜHRCHÜSSELN
GB	MIXING BOWLS
IT	BACINELLE CONICHE, INOX
ES	CALDEROS CÓNICOS, INOX

Material: Edelstahl, mit abgerundetem Rand
Schüsselform: konisch

made of stainless steel, rounded edge
cone-shaped

#	Ø mm	🗑️ l	🛒
199002	160	0,5	1
199003	180	0,9	1
199004	200	1,2	1
199005	225	1,6	1
199006	235	2,0	1
199007	280	3,0	1
199008	320	5,0	1
199009	360	7,0	1
199010	395	8,2	1



1

DE	SCHLAGSCHÜSSELN
GB	MIXING BOWLS
IT	BACINELLE SEMISFERICHE, INOX
ES	CALDEROS SEMIESFÉRICOS, INOX

Material: Edelstahl, mit abgerundetem Rand
Schüsselform: rund

made of stainless steel, rounded edge
round shape

#	📏 mm	🗑️ l	🛒
199000	125	0,3	1
199011	140	0,5	1
199012	165	0,9	1
199013	185	1,25	1
199014	200	1,85	1
199015	230	2,6	1
199017	255	3,2	1
199018	280	4,5	1
199019	330	6,7	1



DE	VORRATSBEHÄLTER
GB	DISPENSER
IT	CONTENITORI CON COPERCHIO
ES	CONTENEDORES CON TAPA

Material: Polypropylen (PP), mit Klappdeckel
(PC), spülmaschinengeeignet

made of polypropylene (PP), with lid (PC),
dishwasher proof

#	↔ mm	🗑️ l	🛒
230150	500 x 160 x 95	4 x 0,7	1
230160	500 x 160 x 95	6 x 0,45	1



DE	SCHNEEBESEN
GB	WHISKS
IT	FRUSTE
ES	BATIDORES

Material: Edelstahl; schwarzer thermo-
plastischer, Griff mit Aufhängeöse,
hitzebeständig bis 200°C, wasserdicht;
spülmaschinenfest; schwere Qualität,
Drahtstärke 1,6 mm; 24 Drähte

made of stainless steel; black coloured thermo-
plastic handle, hook, heat resistant
up to 200°C, water proof,
dishwasher proof; heavy quality,
wire thickness 1,6 mm; 24 wires



	#	↗ mm	
<input checked="" type="checkbox"/>	170080	250	12
<input checked="" type="checkbox"/>	170081	300	12
<input checked="" type="checkbox"/>	170082	350	12
<input checked="" type="checkbox"/>	170083	400	12
<input checked="" type="checkbox"/>	170084	450	12
<input checked="" type="checkbox"/>	170085	500	12



Material: Edelstahl; handlicher Griff, für leichte
Massen; **Drahtstärke 1,6 mm, 24 Drähte**

made of stainless steel; for light mixtures;
wire thickness 1,6 mm, 24 wires

	#	↗ mm	
<input checked="" type="checkbox"/>	170040	250	1
<input checked="" type="checkbox"/>	170041	300	1
<input checked="" type="checkbox"/>	170042	350	1
<input checked="" type="checkbox"/>	170043	400	1
<input checked="" type="checkbox"/>	170044	450	1



BALLOONFORM mit schwarzem Kunststoffgriff
"Exoglas", Ruten aus Edelstahl, hitzebeständig
bis 220°C, wasserdicht, sehr handlich
Drahtstärke 1,5 mm, 12 Drähte

BALLOON-SHAPED black handle made of
"exoglas", wires stainless steel, heat resistant
up to 220°C, water proof, easy handling
wire thickness 1,5 mm, 12 wires

	#	↗ mm	
	170016	450	1

DE	RÜHRBESEN
GB	WHISKS
IT	FRUSTE
ES	BATIDORES

Material: Edelstahl; schwarzer thermo-
plastischer, Griff mit Aufhängeöse,
hitzebeständig bis 200°C, wasserdicht;
spülmaschinenfest; schwere Qualität,
Drahtstärke 2,0 mm; 16 Drähte

made of stainless steel; black coloured
thermoplastic handle, hook, heat resistant
up to 200°C, water proof, dishwasher proof;
heavy quality,
wire thickness 2,0 mm; 16 wires

	#	↗ mm	
<input checked="" type="checkbox"/>	170070	250	12
<input checked="" type="checkbox"/>	170071	300	12
<input checked="" type="checkbox"/>	170072	350	12
<input checked="" type="checkbox"/>	170073	400	12
<input checked="" type="checkbox"/>	170074	450	12
<input checked="" type="checkbox"/>	170075	500	12



1

Drähte gefasst, für schwere Massen,
Drahtstärke 2,3 mm, 16 Drähte

wires connected – for heavy mixtures
wire thickness 2,3 mm, 16 wires

	#	↗ mm	
<input checked="" type="checkbox"/>	170050	350	1
<input checked="" type="checkbox"/>	170051	400	1
<input checked="" type="checkbox"/>	170052	450	1
<input checked="" type="checkbox"/>	170053	500	1
<input checked="" type="checkbox"/>	170054	600	1



mit schwarzem Kunststoffgriff "Exoglas",
Ruten aus Edelstahl, hitzebeständig bis 220°C,
wasserdicht, sehr handlich
Drahtstärke 1,8 mm, 16 Drähte

black handle made of "exoglas",
wires stainless steel, heat resistant up to 220°C,
water proof, easy handling
wire thickness 1,8 mm, 16 wires

	#	↗ mm	
	170010	250	1
	170011	300	1
	170012	350	1
	170013	400	1
	170014	450	1
	170015	500	1



DE	FLACHBESEN
GB	FLAT WHISK
IT	FRUSTE
ES	BATIDORES

Speziell für das Unterheben von schweren
Massen und Saucen, Cremes und Mehl.
Auch für Fettgebäck bestens geeignet.
Drahtstärke 2,0 mm, 4 Drähte

Especially for mixing heavy masses and
sauces, creams and flour.
wire thickness 2,0 mm, 4 wires

	#	↗ mm	
<input checked="" type="checkbox"/>	170079	270	12





DE	FEINKOSTLÖFFEL
GB	GOURMET SPOONS
IT	CUCCHIAI GOURMET
ES	CHARCUTERÍA CUCHARA

aus hochwertigem Kunststoff,
 spülmaschinenfest, mit Haken

made of plastic, dishwasher proof, with hook

#		↔ mm		
203210	● schwarz / black	240	6	
203211	○ weiß / white	240	6	
203212	○ transparent / transparente	240	6	



aus hochwertigem Kunststoff,
 spülmaschinenfest, mit Haken

made of plastic, dishwasher proof, with hook

#		↔ mm		
203220	○ weiß / white	340	1	



DE	ABTROPFLÖFFEL
GB	GOURMET SPOON
IT	CUCCHIAIONE GOURMET
ES	CHARCUTERÍA CUCHARA

aus hochwertigem Kunststoff,
 spülmaschinenfest, mit Haken

made of plastic, dishwasher proof, with hook

#		↔ mm		
203230	● schwarz / black	250	6	

DE	GASTROHANDSCHUH „SILIKON“
GB	GASTRO MITTENS „SILICONE“
IT	GUANTI GASTRO IN „SILICONE“
ES	GUANTES GASTRO „SILICONA“



- Material: Silikon mit Baumwollfutter
- Für Rechts- und Linkshänder
 - Zwischen Daumen und Zeigefinger verstärkt
 - Wasserdicht
 - Flexibles Material
 - Hitzebeständig bis + 250° C
 - Handreinigung max. 30 – 40°C

- Made of silicone with cotton lining
- For right- and left-handed
 - Reinforced between thumb and index finger
 - Waterproof
 - Flexible material
 - Heat resistant up to + 250° C
 - manual cleaning max. 30 – 40°C



1

#	↗ mm	→ mm	
310099	380	150	1



DE	BACKHANDSCHUHE SILIKON
GB	BAKING MITTENS SILICONE
IT	GUANTI DA FORNO IN SILICONE
ES	GUANTES ANTICALORICAS, SILICONA



- 100% Silikon, hitzebeständig bis + 300 °C, flexibles Material, wasserdicht, spülmaschi-
nentauglich, hygienisch, sterilisierbar

- 100% silicone, heat resistant up to + 300 °C, flexible, waterproof, dishwasher proof, hygienic, can be sterilised



#	↗ mm	→ mm	
310031	285	160	1
310032	385	180	1

DE	BACKHANDSCHUH NEOPREN
GB	BAKING MITTENS NEOPRENE
IT	GUANTI DA FORNO IN NEOPRENE
ES	GUANTES ANTICALORICAS NEOPRENO



- Material: Neopren, schwarz
- Für Rechts- und Linkshänder
 - Hitzebeständig bis + 260 °C
 - rutschfest
 - wasserabstoßendes und fleckenresistentes Material
 - Handreinigung max. 30 – 40°C

- Made of neoprene, black
- For right- and left-handed
 - Heat resistant up to + 260 °C
 - non-slip
 - Water repellent and stain resistant material
 - manual cleaning max. 30 – 40°C



#	↗ mm	→ mm	
310085	350	145	1

DE	SPRÜHPISTOLE "ALEXO 200"
GB	SPRAY GUN "ALEXO 200"
IT	PISTOLA POLVERIZZATRICE ELETTRICA "ALEXO 200"
ES	PISTOLA PULVERIZADORA ELÉCTRICA "ALEXO 200"



CE

verarbeitbare Materialien:
Butter, Öle, Fette, Wachse, Gelee, Konfitüre,
Trennmittel und Emulsionen

absolut lebensmitteltauglich,
für warme Flüssigkeiten bis 65 °C
Fördermenge: 260 g/min
Inhalt: 700 ml
Leistung: 60 Watt
Staudruck: 0 – 160 bar
Gewicht: 1,1 kg

usability:
butter, oil, fat, wax, jelly, jam,
releasing agent and emulsion –
for foodstuffs,
usable for liquids max. 65 °C
dispense quantity: 260 g/min
volume: 700 ml
Power: 60 W
Pressure: 0 – 160 bar
Weight: 1,1 kg

wird mit Rundstrahldüse R6 geliefert

supplied with ray nozzle R6

#			
153900	Sprühpistole/spray gun	1	



DE	ZUBEHÖR FÜR SPRÜHPISTOLE "ALEXO 200"
GB	ACCESSORY FOR SPRAY GUN "ALEXO 200"
IT	PEZZI DI RICAMBIO PER PISTOLA POLVERIZZATRICE ELETTRICA "ALEXO 200"
ES	RECAMBIOS PARA PISTOLA PULVERIZADORA ELÉCTRICA "ALEXO 200"

#			
---	--	--	--



153901	Flüssigkeitsaustritt 0,4 mm feinster Wasserstaub Rundstrahldüse R4 / ray nozzle R4	1	
--------	--	---	--



153902	Flüssigkeitsaustritt 0,6 mm Rundstrahldüse R6 / ray nozzle R6	1	
--------	--	---	--



153903	Flüssigkeitsaustritt 0,8 mm für dickflüssigere Flüssigkeiten Rundstrahldüse R8 / ray nozzle R8	1	
--------	--	---	--



153904	zum Reinigen von Backöfen / Combi-Dämpfer Flachstrahldüse F7S / ray nozzle F7S	1	
--------	---	---	--

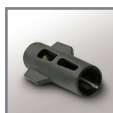

153905	Reinigungsdüse / cleaning nozzle	1	
--------	----------------------------------	---	--



153906	Düsenverlängerung / nozzle extension	1	
--------	--------------------------------------	---	--



153908	Behälter mit Gewinde / tank	1	
153935	Behälter Deckel / Cover	1	
153909	Drall mit Ventillfeder / spin with spring	1	



DE	SPRÜHPISTOLE "ALEXO 400"
GB	SPRAY GUN "ALEXO 400"
IT	PISTOLA POLVERIZZATRICE ELETTRICA "ALEXO 400"
ES	PISTOLA PULVERIZADORA ELÉCTRICA "ALEXO 400"

verarbeitbare Materialien:
Butter, Öle, Fette, Wachse, Gelee, Konfitüre,
Trennmittel und Emulsionen
absolut lebensmitteleuglich,
für warme Flüssigkeiten bis 65 °C
Fördermenge: 350 g/min
Inhalt: 700 ml
Leistung: 90 Watt
Staudruck: 0 – 180 bar
Gewicht: 1,4 kg

usability:
butter, oil, fat, wax, jelly, jam,
releasing agent and emulsion – for foodstuffs,
usable for liquids max. 65 °C,
the removeable parts are dishwasher safe
dispense quantity: 350 g/min
volume: 700 ml
Power: 90 W
Pressure: 0 – 180 bar
Weight: 1,4 kg

wird mit Rundstrahldüse R8 geliefert

supplied with ray nozzle R8



#	Ø mm		
153960	700 / 1400	1	

DE	ANSAUGVORRICHTUNG FÜR "ALEXO 200 + 400"
GB	INDUCTION PIPE FOR "ALEXO 200 + 400"
IT	DISPOSITIVO DI ASPIRAZIONE PER "ALEXO 200 + 400"
ES	DISPOSITIVO DE ASPIRACION PARA "ALEXO 200 + 400"

150 cm Schlauchlänge,
40 cm Rohrlänge (Edelstahl)

hose 150 cm length,
stainless steel pipe 40 cm

#		
153961	1	



Folien Clingfilms Pellicola alimentare Film alimentare

HACCP



DE	FRISCHHALTEFOLIE
GB	CLINGFILMS
IT	PELLICOLE PER ALIMENTI
ES	FILM ESTIRABLE

Material: lebensmittelechte Haftfolie (PE)
hervorragende Hafteigenschaften, atmungsaktiv
geeignet auch zum Verpacken fetthaltiger
Produkte

high quality clingfilm (PE)
excellent adhesive strength, breathable,
usable also for greasy products

“UNIFOL” - PERFORIERT

Materialstärke: 12 µ

“UNIFOL” - PERFORATED

thickness: 12 µ

#	Perforation /perforation mm	↗ m	
131030	250 x 250	500	4
131040	300 x 300	500	4
131050	350 x 350	500	4
131060	400 x 400	500	4
131070	450 x 450	500	4
131080	600 x 600	350	4



“UNIFOL” - ENDLOS

Materialstärke: 12 µ

“UNIFOL” - ENDLESS

thickness: 12 µ

#	→ mm	↗ m	
132040	300	300	4
132070	450	300	4
132090	600	300	4

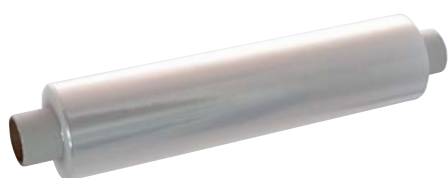

“EUROFOL” - PERFORIERT

Materialstärke: 10 µ

“EUROFOL” - PERFORATED

thickness: 10 µ

#	Perforation /perforation mm	↗ m	
131812	250 x 250	500	4
131813	300 x 300	500	4
131814	360 x 360	500	4
131815	400 x 400	500	4
131816	450 x 450	500	4

“EUROFOL” - ENDLOS

Materialstärke: 10 µ

#	→ mm	↗ m	
131800	290	300	4
131801	440	300	4
131802	590	300	4



1

“EUROFOL” - ENDLESS

thickness: 10 µ

DE	FOLIEN-ABREISSVORRICHTUNG
GB	CLINGFILM TEAR-OFF-DISPENSERS
IT	PORTA PELLICOLE
ES	SOPORTE PARA FILM ESTIRABLE

aus Metall, robuste Ausführung
für Großrollen, mit Schneidekopf

made of metal, for jumbo-rolls, with cutter



#	für / for ↔ mm	
158310	400	1
158320	500	1
158330	860	1

Aus Metall, stabile Ausführung
für perforierte Folien, max. 11 cm Ø
Wandmontage oder als Tischgerät
verwendbar, Breite ca. 20 cm

made of metal, only for
perforated rolls, max. 11 cm Ø
wall fastening and tabletop unit,
width approx. 20 cm



#		
158010	einfach / single	1
158020	doppelt / double	1

aus Metall, stabile Ausführung, mit Säge
für Endlosfolien Ø max. 80 mm

made of metal, with saw, for endless rolls
Ø max. 80 mm

#	für / for ↔ mm		
158110	300	einfach / single	1
158120	450	einfach / single	1
158130	600	einfach / single	1
158210	300	doppelt / double	1
158220	450	doppelt / double	1



Material: Edelstahl, stabile Ausführung, mit
Säge; für Endlosfolien Ø max. 80 mm

made of stainless steel, with saw;
for endless rolls Ø max. 80 mm

#	für / for ↔ mm		
158410	300	einfach / single	1
158420	450	einfach / single	1



Pizza-Zubehör
 Pizza Accessories
 Pizza Accessori
 Accesorios de pizza







DE	PIZZAÖFEN
GB	PIZZA OVEN
IT	FORNI PER PIZZA
ES	HORNO PIZZA



Pizzaöfen für das optimale Backen von frischen oder gefrorenen Flammkuchen und Pizzen. Für den Einsatz in Snack-Bars, Pubs und Cafés hervorragend geeignet.

For the best baking of fresh or frozen tarte flambée and pizzas. Perfect for working in traditional pizzerias and in take-away pizza shops, snack-bars, pubs and cafés.



#	157950	157960
↑ mm	350 x 80 x 410	350 x 80 x 410
↔ mm	520 x 210 x 580	520 x 350 x 580
Anzahl / No. Kammern	1	2
	1750 W	3500 W
	230 – 240 V 50 / 60 Hz	230 – 240 V 50 / 60 Hz
°C	0 – 320	0 – 320
 kg	15	30
Anzahl / No. Pizzen		

DE	PIZZASCHAUFELN
GB	PIZZA PEELS
IT	PALE PER PIZZA
ES	PALA PIZZA

Material: Schaufel und Stiel aus Aluminium Made of aluminium

#	↖ mm	↔ mm		
200647	240 x 170	510	1	

Material: Schaufel aus Aluminium, Stiel aus Holz Made of aluminium, handle made of wood

#	↖ mm	↔ mm		
200640	350 x 305	910	1	
200641	455 x 405	1320	1	



Material: Schaufel und Stiel aus Aluminium, Made of aluminium

#	↖ mm	↔ mm		
200642	280 x 230	910	1	
200643	350 x 305	1320	1	



2

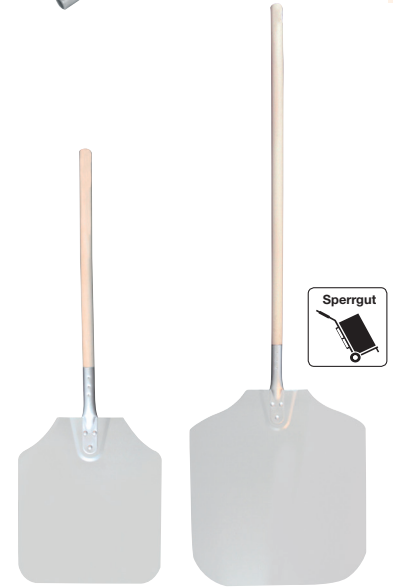

DE	HANDSCHIESSER
GB	OVEN BLADES
IT	PALE PER FORNO
ES	PALA PARA HORNEAR

Material: Buchenholz made of beech wood

#	↗ mm	→ mm		
203411	500	120	1	
203412	500	140	1	
203413	500	160	1	
203414	500	180	1	
203415	950	180	1	
203416	950	200	1	
203417	1150	180	1	
203418	1150	200	1	



DE	PIZZABLECHE	
GB	PIZZA MOULDS	
IT	STAMPI E TEGLIE PER PIZZA IN LAMIERA BLU	
ES	MOLDES Y BANDEJAS PARA PIZZA, DE HIERRO AZUL	

Material: Blaublech.
 Nach Benutzung mit Küchenpapier ausreiben, gut abtrocknen, dann innen und außen mit Speiseöl einreiben.
 Vor Erstgebrauch bei ca. 200° C 10 min. einbrennen und einölen.
 Temperatur bis + 500° C.

Made of blue sheet metal
 After use, rub out with kitchen paper, dry well, then inside and rub the outside with cooking oil.
 Before first use: bake at approx. 200° C for 10 min. and then oil.
 Heat resistant up to + 500° C.

Materialstärke: 0,8 mm

thickness: 0,8 mm



#	↑ Ø mm	↓ Ø mm	↑ mm	
997140	140	125	25	10
997160	160	145	25	10
997180	180	165	25	10
997200	200	180	25	10
997220	220	200	25	10
997240	240	220	25	10
997260	260	240	25	10
997280	280	260	25	10
997300	300	280	25	10
997320	320	300	25	10
997360	360	340	25	10
997400	400	380	25	10
997450	450	425	35	10
997500	500	475	35	10

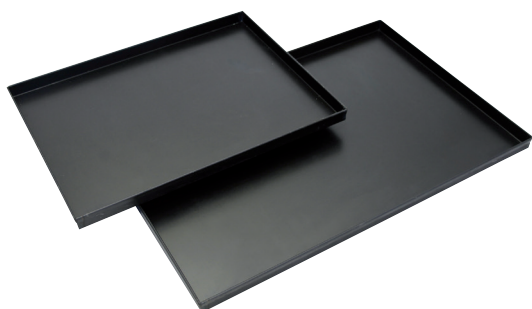

Materialstärke: 0,8 mm

thickness: 0,8 mm

#	→ mm	↓ mm	↑ mm	
997900	400	600	25	1
997901	340	450	25	1
997902	350	500	25	1
997903	300	400	25	1

DE	PIZZABLECHE	
GB	PIZZA MOULDS	
IT	STAMPI E TEGLIE PER PIZZA IN LAMIERA BLU	
ES	MOLDES Y BANDEJAS PARA PIZZA, DE HIERRO AZUL	

Material: Aluminium, nicht spülmaschinenfest
 Perforation: 3 mm

Made of aluminum, not dishwasher safe
 Perforation: 3 mm



#	↑ Ø mm	↓ Ø mm	↑ mm	
997630	180	160	25	10
997631	200	180	25	10
997632	220	200	25	10
997633	240	220	25	10
997634	260	240	25	10
997635	280	260	25	10
997636	300	280	25	10
997637	320	300	25	10
997638	340	320	25	10
997639	360	340	25	10
997640	400	385	25	10

DE	PIZZA GITTER
GB	PIZZA SCREENS
IT	RETINE PER PIZZA
ES	RED PARA PIZZA



Material: Aluminium, nicht spülmaschinenfest Made of aluminum, not dishwasher safe

#	Ø mm		
997620	250	12	
997621	280	12	
997622	300	12	
997623	330	12	
997624	355	12	
997625	405	12	



2

DE	STÄNDER FÜR KUCHEN- UND PIZZABLECHE
GB	SUPPORT FOR CAKE- AND PIZZA MOLDS
IT	SUPORTO PER TEGLIE PIZZA E TORTIERE
ES	RACK PARA PLACES PIZZA Y TARTA



Material: Edelstahl Made of stainless steel
 14 Auflagen von Blechen und Pfannen 14 shelves
 Auflage: 210 x 240 mm Shelf dimension: 210 x 240 mm
 Abstand: 40 mm Distance: 40 mm
Auch zur Wandmontage geeignet. **Also suitable for wall mounting.**

#	↔ mm		
154813	310 x 330 x 770	1	



DE	AUSKÜHLPLATTE FÜR PIZZA / FLAMMKUCHEN
GB	COOLING PIZZA PLATES
IT	PIASTRE DI RAFFREDDAMENTO PER PIZZA
ES	PLACA DE ENFRIAMIENTO DE PIZZA

Material: Edelstahl 18/10 Made of stainless steel, practical display
 Praktisches Display mit Lüflöchern with air holes for cooling hot pizza
 zum Auskühlen

#	Ø mm	↑ mm		
159700	320	50	1	
159701	320	100	1	
159702	320	150	1	



DE	PIZZA-BLECHZANGE
GB	PIZZA-SHEET TONG
IT	PINZA PER TEGLIE
ES	PINZA PARA PLACAS

#	↗ mm		
200646	200	1	



DE	TEIG- UND PIZZASCHNEIDER
GB	DOUGH AND PIZZA CUTTERS
IT	ROTELLE TAGLIA PASTA E PIZZA
ES	RUEDECILLA (PARA MASA Y PIZZA)

Material: Edelstahl, mit Kunststoffgriff mit Handschutz und Aufhängeöse
sehr robuste Ausführung

made of stainless steel, plastic handle and hook, with hand protection
very strong quality



Art. 200005

#		Ø mm	
<input checked="" type="checkbox"/>	200005 einfach, glatt / single, plain	55	1
<input checked="" type="checkbox"/>	200006 einfach gewellt / single serrated	55	1
<input checked="" type="checkbox"/>	200007 doppelt glatt und gewellt / double, plain and serrated	55	1
<input checked="" type="checkbox"/>	200115 einfach, glatt / single, plain	120	1



Art. 200006



Art. 200007



Art. 200115

Material: Edelstahl, mit ergonomischem Griff aus schwarzem PP; ca. 200 mm lang

made of stainless steel, ergonomic handle made of black PP; ca. 200 mm length



#		Ø mm	
200510	einfach, glatt / single, plain	40	1
200511	einfach, glatt / single, plain	55	1
200512	einfach, glatt / single, plain	65	1
200515	einfach gewellt / single serrated	40	1
200516	einfach gewellt / single serrated	55	1
200517	einfach gewellt / single serrated	65	1



NEW

Material: Edelstahl, mit ergonomischem Griff aus schwarzem PP; ca. 255 mm lang

made of stainless steel, ergonomic handle made of black PP; ca. 255 mm length

#		Ø mm	
200116	einfach, glatt / single, plain	125	1

DE	PIZZATEILER
GB	PIZZA CHOPPER
IT	TRONCHI TAGLIAPIZZA
ES	CORTADOR DE PIZZA

Material: Edelstahl
Materialstärke: 1,0 mm, runder Griff

made of stainless steel
thickness 1,0 mm, round handle



#	→ mm	↑ mm	
200625	304	95	1
200626	348	93	1
200627	400	97	1

DE	SCHNEIDER ISOBOX "PIZZA"
GB	SCHNEIDER ISOBOX "PIZZA"
IT	SCHNEIDER CONTENITORI ISOTERMICI ISOBOX "PIZZA"
ES	CONTENEDOR ISOTÉRMICO SCHNEIDER ISOBOX "PIZZA"

für Pizza oder Torten

for pizza or cakes

#	↔ mm	⏏ mm	⏏ l	⚖ g	🛒
280040	410 x 410 x 240	350 x 350 x 175	21	600	1
280041	410 x 410 x 330	350 x 350 x 265	32	800	1
280042	Ersatzdeckel / replacement lid		410 x 410 mm		1



2

DE	TEIGWANNE RECHTECKIG
GB	DOUGH CONTAINER RECTANGULAR
IT	CONTENITORE PER IMPASTO, RETTANGOLARE
ES	BANDEJA PARA MASA, RECTANGULAR

Material: PP, weiß

made of PP, white

#	↗ mm	↔ mm	↑ mm	⏏ l	🛒
202170	600	400	77	14	1
202172	600	400	95	18	1
202173	600	400	130	24	1



DE	DECKEL FÜR TEIGWANNE
GB	LID FOR DOUGH CONTAINER
IT	COPERTURA PER CONTENITORE PER IMPASTO
ES	COBERTURA DE LA BANDEJA PARA MASA

Material: PP, weiß

made of PP, white

#	↗ mm	↔ mm	🛒
202171	600	400	1



DE	PIZZA-OFENBÜRSTEN
GB	PIZZA OVEN BRUSHES
IT	SPAZZOLE PER FORNI DA PIZZA
ES	CEPILLO PARA PARRILLA

Borsten aus Messingdraht, Schaber aus Edelstahl

Bristles made of brass wire, stainless steel scraper

#	↗ mm	🛒
200644	1040	1



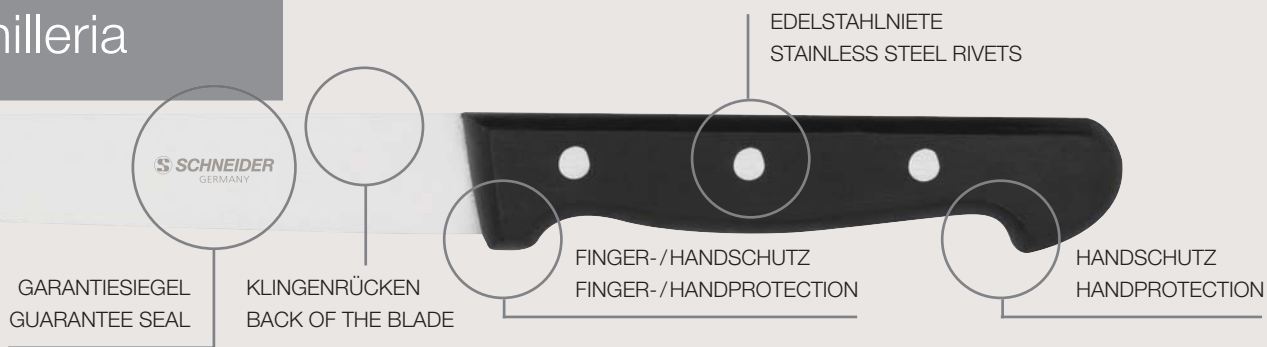

Messer Knives Coltelleria Cuchilleria

- Klingen aus erstklassigem Chrom-Molybdän-Stahl, Messerhärte 52 HRC.
- Ergonomische Schalen-Griffe (POM) mit 2 oder 3 Edelstahlnieten
- Raw blades made of first class chrome-molybdenum steel, knife hardness 52 HRC.
- ergonomically shaped handles made of POM with 2 or 3 stainless steel rivets



DE	KEBAP-MESSER
GB	KEBAB KNIVES
IT	COLTELLO KEBAB
ES	CUCHILLO PARA KEBAB

	#		↗ mm*	→ mm*	🛒
<input checked="" type="checkbox"/>	262350	glatte Schneide, harte Klinge / straight edge 	500	33	1
<input checked="" type="checkbox"/>	262360	glatte Schneide, flexible Klinge / flexible edge 	550	33	1



DE	GYROS-MESSER
GB	GYROS KNIFE
IT	COLTELLO GYROS
ES	CUCHILLO PARA GYROS









	#		↗ mm*	→ mm*	🛒
<input checked="" type="checkbox"/>	262436	Welle / wave 	360	33	1



↗ mm*: Klingenlänge / blade length | → mm*: Klingenbreite / blade width

DE	BÄCKERMESSER
GB	BAKER'S KNIVES
IT	COLTELLO PASTICCERIA
ES	CUCHILLO PARA PASTELERÍA













	#		↗ mm*	→ mm*	🛒
☑	264026	glatte Schneide/ straight edge 	260	33	1
☑	264031	glatte Schneide/ straight edge 	310	33	1
☑	264036	glatte Schneide/ straight edge 	360	33	1
☑	264131	feine Säge/ saw edge 	310	33	1
☑	264136	feine Säge/ saw edge 	360	33	1
☑	264226	Welle / wave 	260	33	1
☑	264231	Welle / wave 	310	33	1
☑	264236	Welle / wave 	360	33	1



3



	#		↗ mm*	→ mm*	🛒
☑	264331	Welle / wave 	310	34	1
☑	264336	Welle / wave 	360	34	1
☑	264431	feine Säge/ saw edge 	310	34	1
☑	264436	feine Säge/ saw edge 	360	34	1
☑	264531	glatte Schneide/ straight edge 	310	34	1
☑	264536	glatte Schneide/ straight edge 	360	34	1
☑	264631	feine Säge, glatte Schneide/ saw edge and straight edge 	310	34	1
☑	264636	feine Säge, glatte Schneide/ saw edge and straight edge 	360	34	1
☑	264731	Wellenschliff, glatte Schneide/ straight edge and wavy edge 	310	34	1
☑	264736	Wellenschliff, glatte Schneide/ straight edge and wavy edge 	360	34	1
☑	264831	Wellenschliff, feine Säge/saw and wavy edge 	310	34	1
☑	264836	Wellenschliff, feine Säge/saw and wavy edge 	360	34	1



↗ mm*: Klingenlänge / blade length | → mm*: Klingenbreite / blade width

DE	KUCHENBLECHMESSER
GB	CAKE KNIFE
IT	COLTELLO DA TORTA E PASTICCERIA
ES	CUCHILLO PARA TARTA Y PASTELERÍA



#		↗ mm*	→ mm*	
<input checked="" type="checkbox"/> 264931	Welle / wave	310	33	1



DE	KUCHENMESSER
GB	CAKE-KNIVES
IT	COLTELLO DA TORTA E PASTICCERIA
ES	CUCHILLO PARA TARTA Y PASTELERÍA



#		↗ mm*	→ mm*	
<input checked="" type="checkbox"/> 265023	glatte Schneide / straight edge	230	34	1
<input checked="" type="checkbox"/> 265028	glatte Schneide / straight edge	280	34	1



#		↗ mm*	→ mm*	
<input checked="" type="checkbox"/> 265123	feine Säge / thin saw edge	230	34	1
<input checked="" type="checkbox"/> 265128	feine Säge / thin saw edge	280	34	1



#		↗ mm*	→ mm*	
<input checked="" type="checkbox"/> 265223	Welle / wave	230	34	1
<input checked="" type="checkbox"/> 265228	Welle / wave	280	34	1



DE	UNIVERSALMESSER
GB	UNIVERSAL KNIFE
IT	COLTELLO UNIVERSALE
ES	CUCHILLO UNIVERSÁL

#		↗ mm*	
<input checked="" type="checkbox"/> 265326	Welle / wave	260	1



↗ mm*: Klingenlänge / blade length | → mm*: Klingenbreite / blade width

DE	KONDITORMESSER
GB	CONFECTIONER'S KNIVES
IT	COLTELLO DA TORTA E PASTICCERIA
ES	CUCHILLO PARA TARTA Y PASTERÍA



	#		↗ mm*	→ mm*	
<input checked="" type="checkbox"/>	265426	glatte Schneide/ straight edge	260	24	1
<input checked="" type="checkbox"/>	265431	glatte Schneide/ straight edge	310	24	1
<input checked="" type="checkbox"/>	265436	glatte Schneide/ straight edge	360	24	1



3

	#		↗ mm*	→ mm*	
<input checked="" type="checkbox"/>	265526	feine Säge/ thin saw edge	260	24	1
<input checked="" type="checkbox"/>	265531	feine Säge/ thin saw edge	310	24	1
<input checked="" type="checkbox"/>	265536	feine Säge/ thin saw edge	360	24	1



	#		↗ mm*	→ mm*	
<input checked="" type="checkbox"/>	265626	Welle / wave	260	24	1
<input checked="" type="checkbox"/>	265631	Welle / wave	310	24	1
<input checked="" type="checkbox"/>	265636	Welle / wave	360	24	1



DE	KÜCHENMESSER
GB	KITCHEN KNIFE
IT	COLTELLO CUCINA
ES	CUCHILLO COCINA



	#		↗ mm*	
<input checked="" type="checkbox"/>	265826	Welle / wave	260	1



DE	WELLEN-BROTMESSER
GB	BREAD KNIVES
IT	COLTELLO DA PANE
ES	CUCHILLO PARA PAN



	#		↗ mm*	
<input checked="" type="checkbox"/>	265921	Welle / wave	210	1
<input checked="" type="checkbox"/>	265926	Welle / wave	260	1



↗ mm*: Klingenlänge / blade length | → mm*: Klingenbreite / blade width



DE	KUCHENBLECHMESSER
GB	CAKE KNIVES
IT	COLTELLO DA TORTA E PASTICCERIA
ES	CUCHILLO PARA TARTA Y PASTERÍA



	#		↗ mm*	
<input checked="" type="checkbox"/>	262518	Welle / wave	180	1
<input checked="" type="checkbox"/>	262522	Welle / wave	220	1



DE	TORTENMESSER
GB	PIE KNIVES
IT	COLTELLO DA TORTA
ES	CUCHILLO PARA TARTA



	#		↗ mm*	
<input checked="" type="checkbox"/>	262600	Schneide/Säge/ plain/saw	160	1
<input checked="" type="checkbox"/>	262601	Schneide/Welle/ plain/wave	160	1
<input checked="" type="checkbox"/>	262602	Säge/Welle/ saw/wave	160	1



DE	BACK- UND GLASURPALETTEN
GB	PALETTE KNIVES
IT	PALETTA SMUSSATA
ES	ESPÁTULA SIN FILO



	#	↗ mm*	→ mm*	
<input checked="" type="checkbox"/>	262612	120	18	1
<input checked="" type="checkbox"/>	262616	160	34	1
<input checked="" type="checkbox"/>	262621	210	34	1
<input checked="" type="checkbox"/>	262626	260	34	1
<input checked="" type="checkbox"/>	262631	310	34	1
<input checked="" type="checkbox"/>	262636	360	34	1

DE	PALETTE MIT WELLENSCHLIFF
GB	PALETTE KNIFE WITH SCALLOPED EDGE
IT	PALETTA SMUSSATA
ES	ESPÁTULA SIN FILO



<input checked="" type="checkbox"/>	#		↗ mm*	→ mm*	
	262640	Welle / wave	310	34	1

↗ mm*: Klingenlänge / blade length | → mm*: Klingenbreite / blade width

DE	TORTENRINGPALETTE
GB	TARTRING SPATULAS
IT	PALETTA PER ANELLO DA TORTA
ES	ESPÁTULA PARA ARO DE TARTAS

	#	↖ mm	→ mm*		
<input checked="" type="checkbox"/>	262825	170 / 250	34	1	



3

DE	WINKELPALETTE
GB	SPATULAS ANGULAR
IT	PALETTA CUOCO CON SCALINO
ES	ESPÁTULA DE PASTELLERO CURVADA

	#	↖ mm	→ mm*		
<input checked="" type="checkbox"/>	262712	100 / 120	18	1	
<input checked="" type="checkbox"/>	262721	150 / 210	34	1	
<input checked="" type="checkbox"/>	262726	200 / 260	34	1	
<input checked="" type="checkbox"/>	262731	250 / 310	34	1	
<input checked="" type="checkbox"/>	262736	300 / 360	34	1	



DE	PFANNENWENDER
GB	PAN FLIPPERS
IT	PALETTE PER HAMBURGER
ES	ESPÁTULA HAMBURGER

	#		↖ mm	→ mm*		
<input checked="" type="checkbox"/>	262901	mit gebogener Klinge/ multi-purpose turner	200 / 260	75	1	
<input checked="" type="checkbox"/>	262902	mit gelochter Klinge/ with perforated blade	200 / 260	75	1	
<input checked="" type="checkbox"/>	262903	mit flexibler Klinge/ flexible turner	120 / 160	87	1	
<input checked="" type="checkbox"/>	262904	mit gebogener Klinge/ multi-purpose turner	240 / 300	75	1	



Art. 262901



Art. 262902



Art. 262903



Art. 262904
"extra lang"

↖ mm*: Klingenlänge / blade length | → mm*: Klingenbreite / blade width

- Klingen aus erstklassigem Chrom-Molybdän-Stahl, Vakuum-gehärtet, 2-fach geschliffen.
- ergonomischer und rutschsicherer Griff aus Kunststoff.

- Raw blades made of first class chrome-molybdenum steel, vacuum hardened, grinding in two steps.
- ergonomically shaped and slip-proof handle made of plastic.



DE	TORTENMESSER
GB	PIE KNIVES
IT	COLTELLI PER TORTE
ES	CUCHILLO PARA TARTA



	#		↗ mm*	
<input checked="" type="checkbox"/>	260610	Schneide/Säge / plain/saw	160	6
<input checked="" type="checkbox"/>	260611	Schneide/Welle / plain/wave	160	6
<input checked="" type="checkbox"/>	260612	Säge/Welle / saw/wave	160	6



DE	KONDITIONMESSER
GB	CONFECTIONER'S KNIVES
IT	COLTELLI PER PASTICCIERE
ES	CUCHILLO PARA PASTERÍA

	#		↗ mm*	
<input checked="" type="checkbox"/>	260630	Schneide / plain	300	6
<input checked="" type="checkbox"/>	260631	Säge / saw	300	6
<input checked="" type="checkbox"/>	260632	Welle / wave	300	6
<input checked="" type="checkbox"/>	260640	Schneide / plain	360	6
<input checked="" type="checkbox"/>	260641	Säge / saw	360	6
<input checked="" type="checkbox"/>	260642	Welle / wave	360	6



↗ mm*: Klingenlänge / blade length



DE	KUCHEN- UND KÜCHENMESSER
GB	CAKE AND PASTRY KNIVES
IT	COLTELLI PER TORTE E CUCINA
ES	CUCHILLO PARA TARTA Y PASTELERÍA



	#			↗ mm*	
<input checked="" type="checkbox"/>	260650	Schneide/plain		310	6
<input checked="" type="checkbox"/>	260651	Säge/saw		310	6
<input checked="" type="checkbox"/>	260652	Welle/wave		310	6



DE	BACKBLECHMESSER, ABGEWINKELT
GB	ANGULAR KNIVES, WAVY EDGE
IT	COLTELLI PER TEGLIE, CON LAMA ANGOLATA
ES	CUCHILLO ANGULAR

































	#			↗ mm*	
<input checked="" type="checkbox"/>	260720	Welle/wave		120	6
<input checked="" type="checkbox"/>	260730	Welle/wave		200	6



↗ mm*: Klingenlänge / blade length









DE	BÄCKERMESSER
GB	BAKER'S KNIVES
IT	COLTELLI PER PANETTIERE
ES	CUCHILLO PARA PASTELERÍA

	#			↗ mm*	🛒
	<input checked="" type="checkbox"/>	260500	Schneide/Säge / plain/saw 	260	6
	<input checked="" type="checkbox"/>	260501	Schneide/Welle / plain/wave 	260	6
	<input checked="" type="checkbox"/>	260502	Säge/Welle / saw/wave 	260	6
	<input checked="" type="checkbox"/>	260510	Schneide/Säge / plain/saw 	300	6
	<input checked="" type="checkbox"/>	260511	Schneide/Welle / plain/wave 	300	6
	<input checked="" type="checkbox"/>	260512	Säge/Welle / saw/wave 	300	6
	<input checked="" type="checkbox"/>	260520	Schneide/Säge / plain/saw 	360	6
	<input checked="" type="checkbox"/>	260521	Schneide/Welle / plain/wave 	360	6
	<input checked="" type="checkbox"/>	260522	Säge/Welle / saw/wave 	360	6
	<input checked="" type="checkbox"/>	260530	Schneide / plain 	260	6
	<input checked="" type="checkbox"/>	260531	Säge / saw 	260	6
	<input checked="" type="checkbox"/>	260532	Welle / wave 	260	6
	<input checked="" type="checkbox"/>	260540	Schneide / plain 	300	6
	<input checked="" type="checkbox"/>	260541	Säge / saw 	300	6
	<input checked="" type="checkbox"/>	260542	Welle / wave 	300	6
	<input checked="" type="checkbox"/>	260550	Schneide / plain 	360	6
	<input checked="" type="checkbox"/>	260551	Säge / saw 	360	6
	<input checked="" type="checkbox"/>	260552	Welle / wave 	360	6
	<input checked="" type="checkbox"/>	260560	Schneide / plain 	250	6
	<input checked="" type="checkbox"/>	260561	Welle / wave 	250	6
	<input checked="" type="checkbox"/>	260570	Schneide / plain 	310	6
	<input checked="" type="checkbox"/>	260571	Welle / wave 	310	6

↗ mm*: Klingenlänge / blade length

DE	BROTMESSER
GB	BREAD KNIVES
IT	COLTELLI DA PANE
ES	CUCHILLO PARA PAN

	#		↗ mm*	
<input checked="" type="checkbox"/>	260580	Schneide/plain 	210	6
<input checked="" type="checkbox"/>	260582	Welle/wave 	210	6
<input checked="" type="checkbox"/>	260590	Schneide/plain 	250	6
<input checked="" type="checkbox"/>	260592	Welle/wave 	250	6
<input checked="" type="checkbox"/>	260600	Brotmesser spezial 	180	6



Art. 260582

Art. 260600

3

DE	BROT- UND AUFSCHNITTMESSER MIT ABSTANDSHALTER
GB	SLICE WITH DISTANCE CONTROLLER
IT	COLTELLI DA PANE CON GUIDA DI TAGLIO
ES	CUCHILLO PARA PAN CON GUÍA DE CORTE

	#		↗ mm*	
<input checked="" type="checkbox"/>	260740	Welle/wave 	210	1
<input checked="" type="checkbox"/>	260742	Welle/wave 	250	1



Art. 260740



Art. 260742



↗ mm*: Klingenlänge / blade length

NEW



DE	THEKEN-DISPLAY „VESPERMESSER“
GB	COUNTER DISPLAY „ALLROUND UTILITY KNIFE“
IT	ESPOSITORE PER COLTELLINI DA PANE
ES	PANTALLA DE CONTADOR CUCHILLO „VESPER“

Vespermesser mit Kunststoffgriff, Micro Schliff, rostfreier Stahl, 20 Stück pro Display
 Allround utility knife with plastic handle, micro ground, stainless steel, 20 pieces per display

#	Inhalt / content	
261800	12 x schwarz , 8 x rot / 12 x black, 8 x red	1



DE	THEKEN-DISPLAY „FRÜHSTÜCKSMESSER“
GB	COUNTER DISPLAY „BREAKFAST KNIFE“
IT	ESPOSITORE PER COLTELLINI DA PANE
ES	PANTALLA DE CONTADOR CUCHILLO DE DESAYUNO

Frühstücksmesser mit Kunststoffgriff, Micro Schliff, rostfreier Stahl, 30 Stück pro Display
 Allround utility knife with plastic handle, micro ground, stainless steel, 30 pieces per display

NEW



#	Inhalt / content	
261810	10 x schwarz , rot, blau / 10 x black, red, blue	1

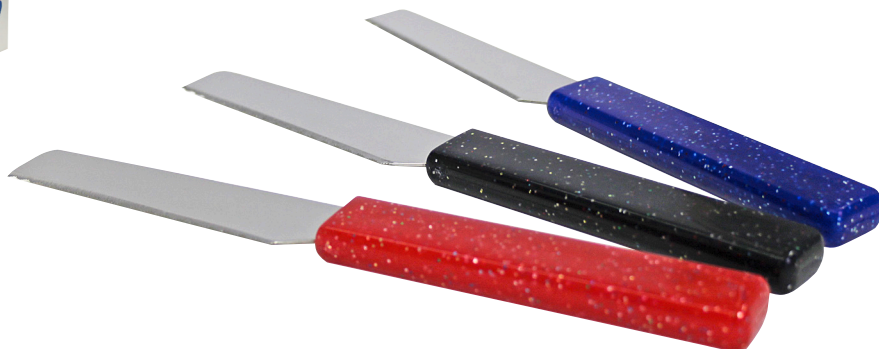

DE	BREZEL-SCHNEIDE-SET
GB	PREZEL CUTTING DEVICE SET INCLUDING KNIFE
IT	SET DA TAGLIO PER BREZEL CON COLTELLO
ES	DISPOSITIVO DE CORTE PRETZEL

Material: Edelstahl mit Schnittführung / Kunststoffscharnier. Zum praktischen Aufschneiden von Brezeln inkl. Messer (200 mm).
 made of stainless steel and plastic handle, with guide for quick slicing of pretzels. Including knife 200mm



#	↔ mm	
154810	195 x 130	1



DE	BRÖTCHENMESSER
GB	ROLL KNIVES
IT	COLTELLIINI DA PANE
ES	CUCHILLO PARA BOLLITOS DE PAN

Klinge: Bandstahl, Länge 18 cm, Wellenschliff blade: hoop steel, length 8 cm, wave edge

#		↗ mm*	
260750	● blau/blue	80	20
260880	● orange/orange	80	20
260881	● rot/red	80	20
260884	● schwarz/black	80	20



3

DE	STREICHMESSER
GB	SPREADERS
IT	COLTELLI PER SPALMARE
ES	RASQUETA

	#	↗ mm*	
<input checked="" type="checkbox"/>	260670	90	1
<input checked="" type="checkbox"/>	260671	120	1



DE	STREICHMESSER MIT WELLENSCHLIFF
GB	SPREADERS WITH WAVY EDGE
IT	COLTELLI PER SPALMARE, SEGHATTATI
ES	RASQUETA, FILO ONDULADO

	#	↗ mm*	
<input checked="" type="checkbox"/>	260672	90	1
<input checked="" type="checkbox"/>	260673	120	1



DE	BÄCKER-KLINGE
GB	BAKER BLADE
IT	LAMETTE USA E GETTA PER PANETTIERE
ES	LÁMINAS DEL PANADERO

Klinge: Edelstahl, Griff und Schutzhülle aus Kunststoff blade made of stainless steel, handle and protection cover made of plastic

#	↔ mm	
260890	125	10



↗ mm*: Klingenlänge / blade length

GLATTER SCHLIFF

Schneider bietet Ihnen den perfekten Klingenschliff für jeden Einsatzbereich und jede Anforderung. Wählen Sie aus einer Vielzahl von Klingensformen- und -längen.

SMOOTH BLADE

Schneider provides perfect blades for all types of applications and requirements. Take your pick from a variety of blade shapes and lengths.



HACCP-KENNZEICHNUNG Verwendungsgebiet:	
● schwarz	Allgemein
● rot	Rohes Fleisch
● blau	Fisch
● grün	Obst und Gemüse
● gelb	Geflügel
● braun	gekochte Lebensmittel
○ weiss	Backwaren / Milchprodukte

HACCP-MARKING Area of use:	
● black	General
● red	Raw Meat
● blue	Fish
● green	Fruits and vegetables
● yellow	Poultry meat
● brown	Cooked food
○ white	Bakery and dairy products



DE	KOCHMESSER – BREITE KLINGE
GB	CHEF'S KNIVES – WIDE BLADE
IT	COLTELLI DA CUCINA – LAMA LARGA
ES	CUCHILLO COCINERO DE HOJA ANCHA

	#		↗ mm*	
<input checked="" type="checkbox"/>	260800	● schwarz / black	200	6
<input checked="" type="checkbox"/>	260801	● schwarz / black	260	6
<input checked="" type="checkbox"/>	260802	● schwarz / black	310	6
<input checked="" type="checkbox"/>	260804	● rot / red	160	6
<input checked="" type="checkbox"/>	260812	● rot / red	200	6
<input checked="" type="checkbox"/>	260805	● blau / blue	160	6
<input checked="" type="checkbox"/>	260813	● blau / blue	200	6
<input checked="" type="checkbox"/>	260806	● grün / green	160	6
<input checked="" type="checkbox"/>	260814	● grün / green	200	6
<input checked="" type="checkbox"/>	260803	● gelb / yellow	160	6
<input checked="" type="checkbox"/>	260811	● gelb / yellow	200	6
<input checked="" type="checkbox"/>	260807	● braun / brown	160	6
<input checked="" type="checkbox"/>	260815	● braun / brown	200	6



↗ mm*: Klingenlänge / blade length

WELLENSCHLIFF

Durch regelmäßige Wellen entlang der Klinge gleitet das Messer sicher und ohne abzurutschen durch Schneidgut mit harten Schalen oder Krusten.

WAVY EDGE

The regularly grinded waves along the cutting edge enable the knife to slide securely and without slipping through hard hides and crusts.



GEZAHNTER SCHLIFF

Zum Schneiden von Obst und Gemüse mit Haut oder härterer Schale. Die Klinge gleitet mühelos durch die Schale, ohne das Schneidgut zu quetschen.

SERRATED EDGE

Suited for the cutting of fruit and vegetables with hard skin. The blade slides effortlessly through the skin without damaging the flesh.



DE	KOCHMESSER – SCHMALE KLINGE
GB	CHEF'S KNIVES – NARROW BLADE
IT	COLTELLI DA CUCINA – LAMA STRETTA
ES	CUCHILLO COCINA DE HOJA ESTRECHA

	#		↗ mm*		
<input checked="" type="checkbox"/>	260830	● schwarz / black	160	6	
<input checked="" type="checkbox"/>	260831	● schwarz / black	180	6	
<input checked="" type="checkbox"/>	260832	● schwarz / black	200	6	
<input checked="" type="checkbox"/>	260833	● rot / red	160	6	
<input checked="" type="checkbox"/>	260834	● rot / red	180	6	
<input checked="" type="checkbox"/>	260835	● rot / red	200	6	
<input checked="" type="checkbox"/>	260836	● blau / blue	160	6	
<input checked="" type="checkbox"/>	260837	● blau / blue	180	6	
<input checked="" type="checkbox"/>	260838	● blau / blue	200	6	
<input checked="" type="checkbox"/>	260839	● grün / green	160	6	
<input checked="" type="checkbox"/>	260840	● grün / green	180	6	
<input checked="" type="checkbox"/>	260841	● grün / green	200	6	



DE	KÜCHENMESSER
GB	KITCHEN KNIFE
IT	COLTELLO DA CUCINA
ES	CUCHILLO COCINA

	#		↗ mm*		
<input checked="" type="checkbox"/>	260810	Schneide/plain	130	6	



↗ mm*: Klingenlänge / blade length



DE	UNIVERSALMESSER
GB	UNIVERSAL KNIFE
IT	COLTELLI UNIVERSALI
ES	CUCHILLO UNIVERSÁL

Wellenschliff

Wave

	#		↗ mm*	
<input checked="" type="checkbox"/>	260700	● schwarz / black	250	6
<input checked="" type="checkbox"/>	260701	● rot / red	250	6
<input checked="" type="checkbox"/>	260702	● blau / blue	250	6
<input checked="" type="checkbox"/>	260703	● grün / green	250	6



DE	UNIVERSALMESSER WELLE
GB	UNIVERSAL KNIVES WAVE
IT	COLTELLI UNIVERSALI ONDULATI
ES	CUCHILLO COCINA, DENTADO

	#		↗ mm*	
<input checked="" type="checkbox"/>	260820	● schwarz / black	110	6
<input checked="" type="checkbox"/>	260819	● rot / red	110	6
<input checked="" type="checkbox"/>	260818	● blau / blue	110	6
<input checked="" type="checkbox"/>	260817	● grün / green	110	6
<input checked="" type="checkbox"/>	260816	● gelb / yellow	110	6



DE	FILIERMESSER
GB	FILLETING KNIFE
IT	COLTELLO PER FILETTARE
ES	CUCHILLO PARA FILETEAR

	#		↗ mm*	
<input checked="" type="checkbox"/>	260850	Schneide/plain	160	6



↗ mm*: Klingenlänge / blade length

DE	GEMÜSEMESSER
GB	VEGETABLE KNIVES
IT	COLTELLI PER VERDURE
ES	CUCHILLO PARA VERDURA

	#		↗ mm*	
<input checked="" type="checkbox"/>	260860	● schwarz / black	100	6
<input checked="" type="checkbox"/>	260861	● rot / red	100	6
<input checked="" type="checkbox"/>	260862	● blau / blue	100	6
<input checked="" type="checkbox"/>	260863	● grün / green	100	6
<input checked="" type="checkbox"/>	260864	● gelb / yellow	100	6
<input checked="" type="checkbox"/>	260865	○ weiss / white	100	6



3

DE	AUSBEINMESSER
GB	BONING KNIFE
IT	COLTELLI PER DISOSSO
ES	CUCHILLO PARA DESHUESAR

	#		↗ mm*	
<input checked="" type="checkbox"/>	260876	● rot / red	160	6
<input checked="" type="checkbox"/>	260877	● blau / blue	160	6



DE	TOURNIERMESSER
GB	BIRD'S BEAK PEELING KNIFE
IT	COLTELLO DA CUOCO
ES	CUCHILLO VERDURE

	#		↗ mm*	
<input checked="" type="checkbox"/>	260878	● grün / green	60	6



↗ mm*: Klingenlänge / blade length



Pflegehinweis:

Alle Messer und Paletten sind grundsätzlich spülmaschineneeignet.
 Die Reinigung in der Spülmaschine ist durch die heute zum Einsatz kommenden Reinigungsmittel jedoch wesentlich aggressiver als die Reinigung von Hand.
 Speisemittelreste wie Obstsäuren, hochkonzentriertes Reinigungsmittel oder langes Verbleiben der Messer im heißen Dampf kann auf den Klingen zu Flecken bzw. im schlimmsten Fall zu Rostbildung führen.
 Gleichzeitig führen starke chemische Reinigungsmittel zu einem elektrochemischen Abbau der Schneide.
 Daher empfehlen wir die Reinigung sofort nach Gebrauch per Hand unter fließendem Wasser mit einem sanften Lappen und einem milden Reinigungsmittel.
 Durch ein anschließend sorgfältiges trocken wischen der Messer mit einem weichen Tuch nach dem Reinigen, werden Flecken auf der Klinge vermieden. Außerdem wird die Schneide geschont und bleibt länger scharf.



DE	PIZZAWENDER
GB	PIZZA FLIPPER
IT	SPATOLA PER PASTICCIO E PIZZA
ES	ESPÁTULA PIZZA

<input checked="" type="checkbox"/>	#	↗ mm*	
<input checked="" type="checkbox"/>	260000	110	6



DE	PFANNENWENDER
GB	PAN FLIPPER
IT	SPATOLA HAMBURGER
ES	ESPÁTULA HAMBURGER

<input checked="" type="checkbox"/>	#	↗ mm*	
<input checked="" type="checkbox"/>	260010	240	6

DE	PALETTEN STUMPF
GB	SPATULAS BLUNT
IT	SPATOLE SMUSSATE
ES	ESPÁTULA SIN FILO

<input checked="" type="checkbox"/>	#	↗ mm*	
<input checked="" type="checkbox"/>	260035	115 – "MINI"	6
<input checked="" type="checkbox"/>	260030	160	6
<input checked="" type="checkbox"/>	260031	210	6
<input checked="" type="checkbox"/>	260032	260	6
<input checked="" type="checkbox"/>	260033	310	6
<input checked="" type="checkbox"/>	260034	36	6



↗ mm*: Klingenlänge / blade length

Instructions for care

All knives and cake spatulas are in general dishwasher proof.

Cleaning by hand is recommended, thus you prevent that the blade gets in contacts with aggressive detergents.

Food remnants such as ascorbic acids, highly concentrated detergents, or prolonged exposure to hot water steam, may cause the blade to stain, or even develop rust, in the worst case.

Strong chemical cleaning agents will at the same time lead to the electrochemical deterioration of the cutting edge.

Right away after each use, we therefore recommend rinsing under running water, using a soft cloth and mild detergent.

Wiping the knife with a soft cloth after cleaning will prevent the blade from developing stains. This will conserve the cutting edge which means it will remain sharper much longer.



DE	WINKELPALETTE
GB	SPATULAS ANGULAR
IT	SPATOLE PER CUOCO CON SCALINO
ES	ESPÁTULA DE PASTELLERO CURVADA

	#	↗ mm*	
<input checked="" type="checkbox"/>	260044	115 – "MINI"	6
<input checked="" type="checkbox"/>	260040	160	6
<input checked="" type="checkbox"/>	260041	210	6
<input checked="" type="checkbox"/>	260042	260	6
<input checked="" type="checkbox"/>	260043	310	6



DE	TORTENRINGPALETTE 90°
GB	TARTRING SPATULA 90°
IT	SPATOLA PER ANELLO DA TORTA 90°
ES	ESPÁTULA PARA ARO DE TARTAS 90°

	#	↗ mm*	
<input checked="" type="checkbox"/>	260050	150	6



DE	KUCHENPALETTEN
GB	CAKE SPATULAS
IT	SPATOLE PER DOLCI
ES	ESPÁTULA PARA PASTELES

	#		↗ mm*	
<input checked="" type="checkbox"/>	260020	stumpf/blunt	160	6
<input checked="" type="checkbox"/>	260021	Welle stumpf/single wave	160	6



↗ mm*: Klingenlänge / blade length



Art. 260905



Art. 260906



DE	UNIVERSALSCHERE
GB	KITCHEN SCISSOR
IT	FORBICI DA CUCINA
ES	TIJERAS DE COCINA

- Klinge aus rostfreiem Edelstahl
- Bruchfeste Kunststoffgriffe
- Justierbare Schraube
- Blades made of stainless steel
- Unbreakable plastic handles
- Adjustable screw

	#		↗ mm	
<input checked="" type="checkbox"/>	260905		71	1
<input checked="" type="checkbox"/>	260906	mit Aushebefunktion / Levering mechanism	71	1
<input checked="" type="checkbox"/>	260907		60	1



Anwendungsbeispiel für Art. 260906



DE	ABZIEHSTAHL/WETZSTAHL
GB	SHARPENING STEELS
IT	AFFILATORI
ES	AFILADOR

	#		↔ mm	
<input checked="" type="checkbox"/>	260900	rund / round	250	1
<input checked="" type="checkbox"/>	260901	rund / round	310	1

	#		↔ mm	
<input checked="" type="checkbox"/>	260902	oval / oval	250	1
<input checked="" type="checkbox"/>	260903	oval / oval	310	1



DE	MESSER-STERILISIERUNGSGERÄT
GB	KNIFE-STERILIZER
IT	STERILIZZATORE PER COLTELLI
ES	ESTAERILIZADOR

- Gehäuse aus Edelstahl, Türe aus Methacrylat
Anti-UV-Dispersion mit Magnetverschluss
Sicherheitsschalter für automatisches Ausschalten der Lampe beim Öffnen der Türe.
Zeiteinstellung 0 – 60 min.
- für ca. 20 Messer
 - Leistung: 16 Watt
 - 230 Volt / 50 Hz
- Stainless steel housing, methacrylate door
Anti-UV dispersion with magnetic closure
Safety switch for automatic shutdown of the lamp when the door is opened.
Timer 0 – 60 min.
- for approx. 20 knives
 - power: 16 W
 - 230 Volt / 50 Hz

#	↔ mm	kg	
260099	510 x 130 x 670	9	1

DE	MAGNETLEISTE
GB	MAGNET BAR
IT	BARRA MAGNETICA
ES	LISTEL MAGNETICO

inklusive Befestigungsmaterial

including fittings

#	↔ mm	
260910	500	1



3

DE	MESSER-ABSTREIFBEHÄLTER – STANDGERÄT
GB	STANDING KNIFE CLEANER – WITH SOCKET
IT	PULISCI COLTELLI – DA BANCO
ES	CONTENEDOR DE LIMPIEZA CUCHILLOS – PARA MESA

Material: Edelstahl, mit Schlitzdeckel, unbeheizt

made of stainless steel, with slot cover, without heating

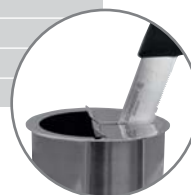

#	↑ mm	∅ mm	↔ mm	
270000	180	100	130	1

DE	MESSER-ABSTREIFBEHÄLTER – EINBAUGERÄT
GB	KNIFE CLEANER – FOR HANGING INTO COUNTERS
IT	PULISCI COLTELLI – DA INCASSO
ES	CONTENEDOR DE LIMPIEZA CUCHILLOS – EMPOTRABLE

Material: Edelstahl, mit Schlitzdeckel, unlaufender Rand 10 mm, unbeheizt, mit Außen- und Innenbehälter; der Innenbehälter wird zum Wasserwechsel herausgenommen

made of stainless steel, with slot cover, circulatory edge 10 mm, without heating, with outer and inner container; the inner container can be removed for water exchange



#	↑ mm	∅ mm	↔ mm	
270003	180	100	125	1

DE	MESSER-ABSTREIFBEHÄLTER – WANDGERÄT
GB	KNIFE CLEANER – FOR FIXING ON WALLS
IT	PULISCI COLTELLI – DA MURO
ES	CONTENEDOR DE LIMPIEZA CUCHILLOS – PARA MURO

Material: Edelstahl, mit Schlitzdeckel, unbeheizt, mit Außen- und Innenbehälter; der Innenbehälter wird zum Wasserwechsel herausgenommen, inklusive Wandhalterung

made of stainless steel, with slot cover, without heating, with outer and inner container; the inner container can be removed for water exchange, including wall fastening

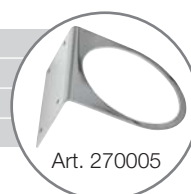

Art. 270005



#	↑ mm	∅ mm	↔ mm	
270004	180	100	135	1
270005	nur Halter passend für Art. 270003			1

#	Ersatzteile / replacement parts	
270001	Abstreifgummi / cleaning rubber	1
270002	Bodengummi / round rubber base	1
270006	Deckel / cover	1

Art. 270001

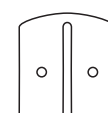

Art. 270002



Art. 270006

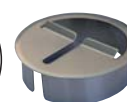



HACCP-KENNZEICHNUNG Verwendungsgebiet:	
● schwarz	Allgemein
● rot	Rohes Fleisch
● blau	Fisch
● grün	Obst und Gemüse
● gelb	Geflügel
● braun	gekochte Lebensmittel
○ weiss	Backwaren / Milchprodukte
● lila	Antiallergisch

HACCP-MARKING Area of use:	
● black	General
● red	Raw Meat
● blue	Fish
● green	Fruits and vegetables
● yellow	Poultry meat
● brown	Cooked food
○ white	Bakery and dairy products
● purple	Antiallergic

DE	SCHNEIDBRETTER
GB	CUTTING BOARDS
IT	TAGLIERI
ES	PLANCHA

PP, ohne FüÙe, spülmaschinengeeignet, geruchs- und geschmacksneutral, schont die Messerklingen.

Stärke: 1,0 cm

Made of PP, without feet, dishwasher proof, neutral smell and taste, protects the knife blades.

Thickness: 1,0 cm

#	↔ mm		
228300	450 x 300	○ weiss / white	1
228301	450 x 300	● braun / brown	1
228302	450 x 300	● grün / green	1
228303	450 x 300	● rot / red	1
228304	450 x 300	● gelb / yellow	1
228305	450 x 300	● blau / blue	1

DE	SCHNEIDBRETTER GN 1/1
GB	CUTTING BOARDS GN 1/1
IT	TAGLIERI GN 1/1
ES	PLANCHA GN 1/1

Material: HD-PE 500, mit FüÙen, spülmaschinengeeignet, schwere Qualität, geruchs- und geschmacksneutral, schont die Messer-klingen.

Stärke: 2,0 cm

Made of HD-PE 500, with feet, dishwasher proof, heavy quality, neutral smell and taste, protects the knife blades.

Thickness: 2,0 cm

#	↔ mm		
228310	530 x 325	○ weiss / white	1
228311	530 x 325	● braun / brown	1
228312	530 x 325	● grün / green	1
228313	530 x 325	● rot / red	1
228314	530 x 325	● gelb / yellow	1
228315	530 x 325	● blau / blue	1
228316	530 x 325	● lila / purple	1



DE	SCHNEIDEBRETT-SET HACCP
GB	CUTTING BOARD SET HACCP
IT	SET TAGLIERE HACCP
ES	JUEGO DE PLACAS DE CORTE HACCP

Material: HD-PE
 Die stabile Bodenplatte hält die farbigen Schneideunterlagen immer fixiert, austauschbar
 Spülmaschinengeeignet, geruchs- und geschmacksneutral, schont die Messerklingen
 Schneideunterlagen: je 3 mm Stärke
 Farben: rot, gelb, grün, blau, weiss, braun

Material: HD-PE
 The stable base plate keeps the coloured cutting pads always fixed, exchangeable
 Dishwasher safe, odourless and tasteless, protects the knife blades
 cutting pads: each 3 mm thick
 Colours: red, yellow, green, blue, white, brown

#	↔ mm	↑ mm	
228330	400 x 300	38	1



DE	SCHNEIDEBRETT-SET HACCP – ERSATZ
GB	CUTTING BOARD SET HACCP – REPLACEMENT SET
IT	SET TAGLIERE HACCP – RICAMBI
ES	JUEGO DE PLACAS DE CORTE HACCP – PIEZAS DE REPUESTO

Farben: rot, gelb, grün, blau, weiss, braun

Colours: red, yellow, green, blue, white, brown

#	↔ mm	↑ mm	
228331	400 x 300	18	1



DE	ABTROPFSTÄNDER FÜR 6 SCHNEIDEBRETTER
GB	DRAINING RACK FOR 6 CUTTING BOARDS
IT	RIPIANO DI DRENAGGIO PER 6 TAGLIERI
ES	ESCURREPLATOS PARA 6 TABLAS DE CORTE

Material: Chromnickelstahl, rostfrei

Made of stainless chrome-nickel steel

#	↔ mm	
228340	270 x 270 x 270	1



DE	SCHNEIDEBRETTHOBEL
GB	BOARD SCRAPER
IT	RASCHIETTO
ES	RASCADOR

Material: PE-HD, weiss

Made of PE-HD, white

#	↔ mm	
228130	160 x 60	1
228131	Ersatzklinge / spare blade	1



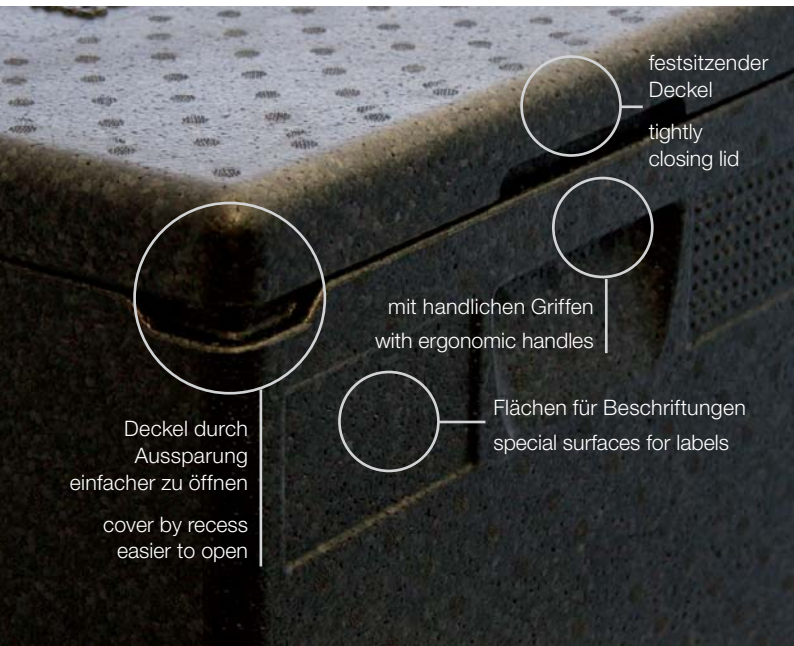

Deckel durch Aussparung einfacher zu öffnen
cover by recess easier to open

mit handlichen Griffen
with ergonomic handles

Flächen für Beschriftungen
special surfaces for labels

festsitzen-
der Deckel
tightly
closing lid



Art. 280016
Isobox extra hoch!



DE	SCHNEIDER ISOBOX "GASTRO GN 1/1"
GB	SCHNEIDER ISOBOX "GASTRO GN 1/1"
IT	SCHNEIDER CONTENITORE ISOTERMICO "GASTRO GN1/1"
ES	CONTENEDOR ISOTÉRMICO SCHNEIDER ISOBOX "GASTRO GN1/1"

für Küchen, Kantinen und Catering

for foodservice, canteens and catering

#	↔ mm	⏏ mm	♻ l	⚖ g	🛒
280011	600 x 400 x 230	538 x 337 x 167	30	900	1
280012	600 x 400 x 280	538 x 337 x 217	39	1000	1
280013	600 x 400 x 320	538 x 337 x 257	46	1100	1
280016	600 x 400 x 400	538 x 337 x 337	61	1400	1
280014	Ersatzdeckel / replacement lid				1



DE	KÜHLAUFSAETZE FÜR SCHNEIDER ISOBOXEN
GB	COOLING TOPS FOR SCHNEIDER ISOBOXES
IT	INSERTI PER CONTENITORI SCHNEIDER ISOBOX
ES	ELEMENTOS DE ENCAJE DE REFRIGERACIÓN PARA SCHNEIDER ISOBOX

#	für / for	🛒
280019	GN 1/1	1



DE	FAHRGESTELL
GB	TROLLEY
IT	CARRELLO PER CONTENITORI IMPILABILI ED ISOTERMICI
ES	CARRETILLA



für alle Stapelbehälter und Isoboxen im Grundmaß 400 x 600 mm, mit je 2 Lenk- und Bockrollen

for all stacking containers and Isoboxes with 400 x 600 mm bottom dimensions, 2 fixed and 2 steering castors

#		🛒
202092	Edelstahl / stainless steel	1
202099	rot / red	1



4

- Das optimale Transport- und Lagersystem für heiße und kalte Produkte
 - Einsetzbar von -40 °C bis +120 °C
 - Aus expandiertem Polypropylen (EPP) und daher absolut bruchstabil und langlebig
 - Hygienisch, geschmacksneutral, spülmaschinenfest
 - Leicht zu transportieren
 - Langsamer Temperaturverlust aufgrund sehr hoher Isoliereigenschaften
 - Unterstützt HACCP-Konzept
- The effective transport and storage system for hot and cold products
 - Usable from -40 °C to +120 °C
 - Made of expanded polypropylene (EPP), absolutely durable
 - Hygienic, odourless and dishwasher-proof
 - Easy to handle
 - Slow temperature loss due to high isolation properties
 - In support of HACCP-concept

DE	SCHNEIDER ISOBOX "GASTRO GN 1/2"
GB	SCHNEIDER ISOBOX "GASTRO GN 1/2"
IT	SCHNEIDER CONTENITORE ISOTERMICO "GASTRO GN1/2"
ES	CONTENEDOR ISOTÉRMICO SCHNEIDER "GASTRO GN1/2"

für Küchen, Kantinen und Catering mit Kunststofftragebügel (PE)

for foodservice, canteens and catering with plastic handle (PE)

#	↔ mm	⏏ mm	⏏ l	⚖ g	🛒
280020	400 x 320 x 345	345 x 265 x 285	26	1000	1
280021	Ersatzdeckel / replacement lid				





DE	SCHNEIDER ISOBOX "SALTO"	
GB	SCHNEIDER ISOBOX "SALTO"	
IT	SCHNEIDER CONTENITORE ISOTERMICO "SALTO"	
ES	CONTENEDOR ISOTÉRMICO SCHNEIDER "SALTO"	

für Backbleche, Stapelbehälter oder Tablets im Format 400 x 600 mm, Lieferung ohne Deckel, stapelbar, **IsoBox kann als Boden oder Deckel verwendet werden**

For baking tins, stacking containers or trays, size 400 x 600 mm, without lid **IsoBox is usable as a box or lid**

#	↔ mm	↑ mm	♻ l	⚖ g	🛒
280033	685 x 485 x 125	625 x 425 x 80	18	640	1
280034	685 x 485 x 165	625 x 425 x 120	32	700	1



DE	SCHNEIDER ISOBOX "MULTISTAR"	
GB	SCHNEIDER ISOBOX "MULTISTAR"	
IT	SCHNEIDER CONTENITORE ISOTERMICO "MULTISTAR"	
ES	CONTENEDOR ISOTÉRMICO SCHNEIDER "MULTISTAR"	

für Backbleche, Stapelbehälter oder Tablets im Format 400 x 600 mm, inklusive Deckel

for baking tins, stacking containers or trays, size 400 x 600 mm, including lid

#	↔ mm	↑ mm	♻ l	⚖ g	🛒
280030	685 x 485 x 260	625 x 425 x 200	53	1500	1
280032	685 x 485 x 360	625 x 425 x 300	80	1600	1
280031	Ersatzdeckel / replacement lid		685 x 485 mm		1



DE	KÜHLAUFsätze FÜR SCHNEIDER ISOBOXEN
GB	COOLING TOPS FOR SCHNEIDER ISOBOXES
IT	INSERTI PER CONTENITORI SCHNEIDER ISOBOX
ES	ELEMENTOS DE ENCAJE DE REFRIGERACIÓN PARA SCHNEIDER ISOBOX

#	für / for	🛒
280039	MULTISTAR	1



DE	SCHNEIDER ISOBOX "PIZZA"	
GB	SCHNEIDER ISOBOX "PIZZA"	
IT	SCHNEIDER CONTENITORE ISOTERMICO "PIZZA"	
ES	CONTENEDOR ISOTÉRMICO SCHNEIDER ISOBOX "PIZZA"	

für Pizza oder Torten

for pizza or cakes

#	↔ mm	↑ mm	♻ l	⚖ g	🛒
280040	410 x 410 x 240	350 x 350 x 175	21	600	1
280041	410 x 410 x 330	350 x 350 x 265	32	800	1
280042	Ersatzdeckel / replacement lid		410 x 410 mm		1

DE	SCHNEIDER ISOBOX "CARGO"
GB	SCHNEIDER ISOBOX "CARGO"
IT	SCHNEIDER CONTENITORE ISOTERMICO "CARGO"
ES	CONTENEDOR ISOTÉRMICO SCHNEIDER "CARGO"

zum Transportieren und Aufbewahren mit Kunststofftragebügel (PE) for transport and storage with plastic handle (PE)

#	↔ mm	↑ mm	🗲 l	⚖ g	🛒
280050	325 x 255 x 325	275 x 205 x 275	15	650	1
280051	Ersatzdeckel / replacement lid				1



4

DE	SCHNEIDER ISOBOX "EIS"	
GB	SCHNEIDER ISOBOX "ICE CREAM"	
IT	SCHNEIDER CONTENITORE ISOTERMICO "GELATO"	
ES	CONTENEDOR ISOTÉRMICO SCHNEIDER "HELADO"	

#	↔ mm	↑ mm	🗲 l	⚖ g	🛒
280075	600 x 400 x 270	3x: 360 x 165 x 150	26	1100	1
280078	600 x 400 x 215	2x: 360 x 250 x 150	16	1000	1



DE	SCHNEIDER ISOBOX AUFSATZRAHMEN "EIS"	
GB	SCHNEIDER ISOBOX EXTENSION FRAME "ICE CREAM"	
IT	INSERTO PER CONTENITORE ISOTERMICO SCHNEIDER "GELATO"	
ES	CONTENEDOR ISOTÉRMICO SCHNEIDER ISOBOX ELEMENTO DE ENCAJE "HELADO"	

für Eisbox 280075 und 280078 for Ice Cream box 280075 and 280078

#	↔ mm	↑ mm	⚖ g	🛒
280076	600 x 400	90	500	1



DE	KÜHLAKKUS FÜR SCHNEIDER ISOBOXEN
GB	COOLING PACKS FOR SCHNEIDER ISOBOXES
IT	PLACCHE EUTETTICHE PER CONTENITORI ISOTERMICI SCHNEIDER ISOBOX
ES	PLACAS EUTÉCTICAS PARA SCHNEIDER ISOBOX

verwendbar bis -21 °C up to -21 °C



GN 1/1



GN 1/3



GN 1/4



GN 1/9

-3°C

-12°C

-21°C

#	GN / mm	↔ mm	⚖ g	🛒
281001	1/9	176 x 108 x 30	500	1
281002	1/4	265 x 162 x 30	1000	1
281003	1/3	325 x 176 x 30	1500	1
281004	1/1	530 x 325 x 30	3950	1
281005	40 x 60	600 x 400 x 28	5200	1
281006	1/9	176 x 108 x 30	500	1
281007	1/4	265 x 162 x 30	1000	1
281008	1/3	325 x 176 x 30	1500	1
281009	1/1	530 x 325 x 30	3950	1
281010	40 x 60	600 x 400 x 28	5200	1
281011	1/9	176 x 108 x 30	500	1
281012	1/4	265 x 162 x 30	1000	1
281013	1/3	325 x 176 x 30	1500	1
281014	1/1	530 x 325 x 30	3950	1
281015	40 x 60	600 x 400 x 28	5200	1



DE	TORTENBOX
GB	CAKE BOX
IT	CONTENITORE PER TORTE
ES	CAJA PARA TORTAS

Material: EPS
 Farbe: weiß
 Leicht, stabil, stapelbar
 Hohe Isoliereigenschaft.
 Innenraum abgerundet, somit ist die Torte beim Transport bestens geschützt.

Made of EPS.
 Colour: white
 Light, stable, stackable
 High isolating characteristic.
 The interior is rounded, so that the cake is optimally protected during transport.

#	↔ mm	↑ mm	∅ mm	⚖ g	🛒
280100	280 x 280 x 190	250 x 250 x 150	250	128	1
280101	320 x 320 x 145	290 x 290 x 110	290	124	1



Art. 280100



Art. 280101



DE	SCHNEIDER ISOBOX "TORTE" RUND
GB	SCHNEIDER ISOBOX "CAKE" ROUND
IT	CONTENITORE ISOTERMICO SCHNEIDER "TORTA" TONDO
ES	CONTENEDOR ISOTÉRMICO SCHNEIDER ISOBOX "REDONDO"

#	∅ mm	☞ ∅ mm	⚖ g	🛒
280070	400 x 200	340 x 140	550	1

DE	SNACKTRANSPORTBOX
GB	SNACK TRANSPORTBOX
IT	CONTENITORI DI SNACK PER IL TRASPORTO
ES	CONTENEDORES BOCADILLOS PARA EL TRANSPORTE

Material: Aluminium
 zum Transportieren von frischen Sandwiches und Snacks

made of aluminum
 for transportation of fresh sandwiches and snacks



#	↔ mm	🛒
154086	355 x 275 x 80	1
154087	355 x 275 x 40	1
154088	Deckel / lid: 355 x 275	1



DE	VORRATSBEHÄLTER / ZUTATENBEHÄLTER
GB	INGREDIENT STORAGE CONTAINERS
IT	CONTENITORI DA STOCCAGGIO
ES	CONTENEDOR

abgerundete Ecken, glatte Oberfläche um sauberes Reinigen zu gewährleisten, Deckel durchsichtig

rounded edges, smooth surface to allow thorough cleaning, transparent lid

#	↔ mm	📦 l	🛒
200891	310 x 375 x 215	8	1
200892	280 x 595 x 430	20	1
200893	480 x 630 x 430	40	1



DE	VORRATSBEHÄLTER / FAHRBAR	 nur LKW
GB	INGREDIENT STORAGE TROLLEY	
IT	CONTENITORE DA STOCCAGGIO / MOBILE	
ES	CONTENEDOR CON RUEDAS	

4 Rollen, abgerundete Ecken, glatte Oberfläche für maximale Hygiene, Deckel durchsichtig, 2-teilig, inklusive Schaufel

4 wheels, rounded edges, smooth surface to allow spotless cleaning, transparent lid, 2-pieces, including scoop

#	↔ mm	📦 l	🛒
200890	333 x 743 x 711	81	1





DE	EIMER
GB	BUCKET
IT	SECCHI
ES	CUBO

Material: NPE, weiß, schwere Qualität, mit Ausguss, Metallbügel und Literskala
 made of LDPE, white, heavy duty quality, with metal handle, spout and measuring scale

#	l	Ø mm	↑ mm	
200830	10	280	300	1
200840	15	320	330	1



Material: NPE, weiß-natur, mit Ausguss, Metallbügel und Literskala
 made of LDPE, white-nature, with metal handle, spout and measuring scale

#	l	Ø mm	↑ mm	
200880	12	300	265	1
200881	15	320	290	1
200882	18	360	305	1



Material: Edelstahl, flacher Boden, mit Skala (innen)
 made of stainless steel, with flat bottom, with scale (inside)

#	l	Ø mm	↑ mm	
200850	10	295	285	1
200860	12	330	270	1
200870	15	345	315	1
200855	Deckel für Eimer/ lids for buckets Art. 200850			1
200865	Deckel für Eimer/ lids for buckets Art. 200860			1
200875	Deckel für Eimer/ lids for buckets Art. 200870			1



DE	TEIGWANNEN RECHTECKIG
GB	DOUGH CONTAINERS RECTANGULAR
IT	CONTENITORI PER IMPASTO, RETTANGOLARI
ES	BANDEJA PARA MASA, RECTANGULAR

Material: PE, weiß
 made of PE, white

#	l	↔ mm	
200960	20	530 x 405 x 145	1
200962	12	440 x 320 x 155	1
NEW 200963	25	610 x 440 x 150	1



DE	TEIGWANNEN RUND
GB	DOUGH CONTAINERS ROUND
IT	CONTENITORI PER IMPASTO, TONDI
ES	BANDEJA PARA MASA, REDONDA

Material: PE, weiß
 made of PE, white

#	l	Ø mm	↑ mm	
200970	14	370	175	1
200971	19	420	150	1

DE	KÜBEL
GB	BUCKETS
IT	SECCHI
ES	CUBOS

Material: HD PE, weiß, mit zwei Griffen made of PE HD, white, with two handles

#	 l	↑ Ø mm	↓ Ø mm	↑ mm	
202000	35	390	310	410	1
202010	50	450	360	480	1
202020	75	490	390	575	1
202030	100	520	410	670	1
202005	Deckel für Kübel/ lid for bucket Art. 202000				1
202015	Deckel für Kübel/ lid for bucket Art. 202010				1
202025	Deckel für Kübel/ lid for bucket Art. 202020				1
202035	Deckel für Kübel/ lid for bucket Art. 202030				1



4

DE	FAHRGESTELL FÜR KÜBEL
GB	TROLLEY FOR BUCKETS
IT	CARRELLO PER SECCHI
ES	CARRETILLA PARA CUBOS REDONDOS



Material: Edelstahl, verstellbar made of stainless steel, adjustable

#	für / for	
202098	202000, 202010, 202020, 202030	1



DE	STAPELBEHÄLTER
GB	STACKABLE BASKETS
IT	CONTENITORI IMPILABILI
ES	CONTENEDORES APILABLES

Material: HD PE, weiß, mit Deckel made of PE HD, white, with lid

#	 l	↔ mm	⏏ mm	
202100	50	560 x 410 x 290	465 x 380 x 290	1
202110	65	630 x 440 x 330	530 x 390 x 325	1
202120	90	740 x 460 x 360	620 x 420 x 350	1



Backen
Baking
Cottura
Cocer



DE	GN-BACKBLECHE / KONVEKTOMATENBLECHE
GB	GN-BAKING TRAYS
IT	TEGLIE GN
ES	GN-PLACAS



Material: Stahlblech, Granit-Emaille,
beidseitig beschichtet
Materialstärke: 1,0 mm

Material: Steel panel, granite emaille,
coated on both sides
thickness: 1,0 mm

GN 2/1
Ausführung: 4 Seiten 90°

GN 2/1
type: 4 sides 90°

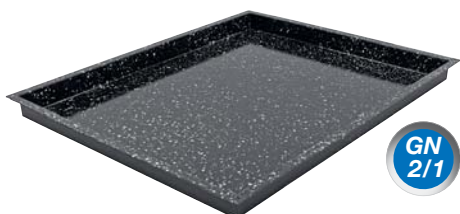

#	↗ mm	→ mm	↑ mm	
382500	530	650	20	1
382501	530	650	40	1
382502	530	650	60	1

GN 1/1
Ausführung: 4 Seiten 90°

GN 1/1
type: 4 sides 90°

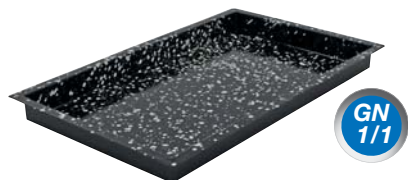

#	↗ mm	→ mm	↑ mm	
382510	530	325	20	1
382511	530	325	40	1
382512	530	325	60	1

GN 2/3
Ausführung: 4 Seiten 90°

GN 2/3
type: 4 sides 90°

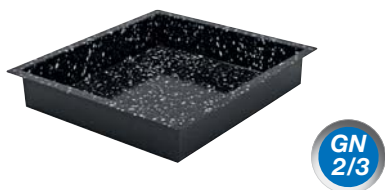

#	↗ mm	→ mm	↑ mm	
382520	354	325	20	1
382521	354	325	40	1
382522	354	325	60	1

DE	GN-BACKBLECHE / KONVEKTOMATENBLECHE
GB	GN-BAKING TRAYS
IT	TEGLIE GN
ES	GN-PLACAS



Material: Stahlblech, Emaille, schwarz
 Beidseitig beschichtet, antihaft
 Abgerundete Ecken

Made of steel, enamel, black
 Coated on both sides, non-stick
 Rounded corners



GN 1/1
Ausführung: 4 Seiten 90°

GN 1/1
type: 4 sides 90°

#	↗ mm	→ mm	↑ mm	⊞ l	🛒
382530	530	325	20	3,0	1
382531	530	325	40	6,0	1
382532	530	325	65	9,75	1



5



DE	GN-BEHÄLTER AUS EDELSTAHL
GB	GN-CONTAINERS MADE OF STAINLESS STEEL
IT	CONTENITORI GN IN ACCIAIO INOX
ES	CONTENEDORES GASTRONORM ACERO INOXIDABLE



#	GN	↑ mm	⊞	🛒
530200	1/1	20	1,9	12
530201	1/1	40	4,5	12
530202	1/1	65	7,4	12
530203	1/1	100	12,6	12



DE	GRILLROSTE
GB	GRIDS
IT	GRIGLIE
ES	REJILLAS

Material: Edelstahl

Made of stainless steel



#		↗ mm	→ mm	≡	∅ mm	Drähte / ∅ Draht mm	🛒
156110		600	400	2	6	24 / 3	1
156111	GN 1/1	530	325	1	7	20 / 3	1
156112	GN 2/3	354	325	1	5	15 / 2	1
156113	GN 2/1	650	530	3	6	32 / 2	1

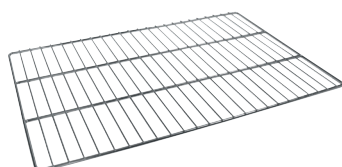

Art. 156110

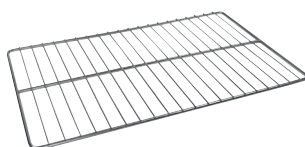

Art. 156111

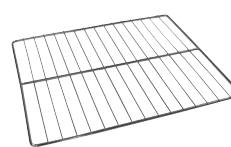

Art. 156112

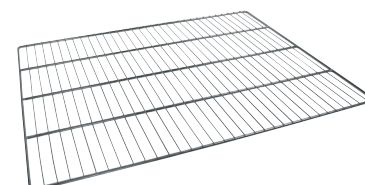

Art. 156113

Backbleche BAKING Trays

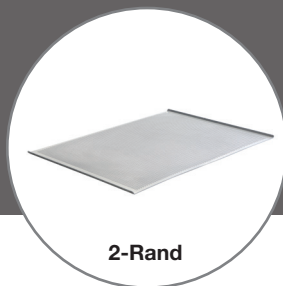

2-Rand

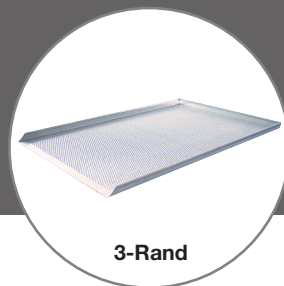

3-Rand

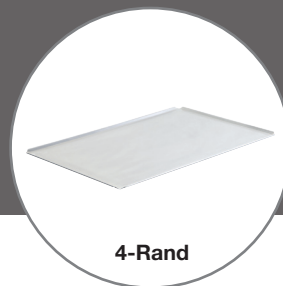

4-Rand



Aluminium

- Robust
- Stapelbar
- Einfach zu reinigen
- Hohe Stabilität
- Langlebig

- Robust
- Stackable
- Easy to clean
- High stability
- Durable

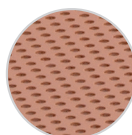
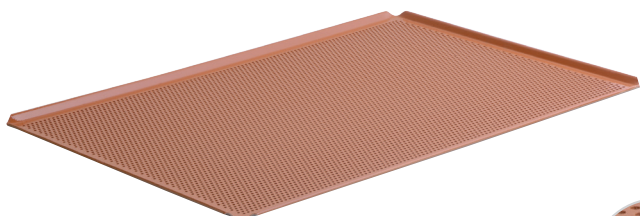

Silikon-Beschichtung

- Antihafbeschichtung auf Silikonbasis
- Farbe: rot
- Hohe Lebensdauer
- Einsetzbar bis maximal + 260° C

- Silicone-based non-stick coating
- Colour: red
- High durability
- Can be used up to a maximum of + 260° C

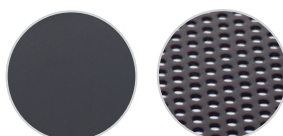

TYNECK-Beschichtung

- Thermoplastische Beschichtung
- Farbe: schwarz
- Sehr lange Lebensdauer
- Laugenresistent
- Hohe Antihaf-Eigenschaft
- Sehr robuste Oberfläche
- Schnitt- und Kratzfest
(bei handelsüblichem Gebrauch und Umgang)
- Einsetzbar bis maximal + 260° C

- Thermoplastic coating
- Colour: black
- Very high durability
- Resistant to alkalis / lye
- High non-stick property
- Very robust surface
- Cut and scratch resistant
(for normal commercial use and handling)
- Can be used up to a maximum of + 260° C

 Sondergrößen auf Anfrage. / Special sizes upon request.

DE	BACKBLECHE
GB	BAKING TRAYS
IT	TEGLIE
ES	PLACAS

mit und ohne Lochung /
with or without perforation

Material: Aluminium (AlMn)

Made of aluminium

	↔ mm		#	⊙ mm	⊥ mm		↑ mm		
	530 x 325	GN 1/1 4 Seiten 45° / 4 sides 45°	381050	–	1,5	unbeschichtet/ uncoated	10	10	
	530 x 325	GN 1/1 4 Seiten 45° / 4 sides 45°	381051	3	1,5	unbeschichtet/ uncoated	10	10	
 NEW	530 x 325	GN 1/1 4 Seiten gezogen / 4 sides deep-drawn	381057	3	1,5	unbeschichtet/ uncoated	10	10	
	530 x 325	GN 1/1 4 Seiten 45° / 4 sides 45°	381052	3	1,5	Silikon / silicone	10	10	
	650 x 530	GN 2/1 4 Seiten 45° / 4 sides 45°	381054	3	1,5	Silikon / silicone	10	10	
 NEW	354 x 325	GN 2/3 4 Seiten 45° / 4 sides 45°	381058	3	1,5	Silikon / silicone	10	10	
	530 x 325	GN 1/1 4 Seiten 45° / 4 sides 45°	382000	–	1,5	Tyneck	10	10	
 NEW	530 x 325	GN 1/1 4 Seiten gezogen / 4 sides deep-drawn	382030	–	1,5	Tyneck	10	10	
	354 x 325	GN 2/3 4 Seiten 45° / 4 sides 45°	382020	–	1,5	Tyneck	10	10	
 NEW	354 x 325	GN 2/3 4 Seiten 45° / 4 sides 45°	382040	3	1,5	Tyneck	10	10	
	530 x 325	GN 1/1 4 Seiten 45° / 4 sides 45°	382010	3	1,5	Tyneck	10	10	

5

mit und ohne Lochung /
with or without perforation

DE	BACKBLECHE
GB	BAKING TRAYS
IT	TEGLIE
ES	PLACAS

Material: Aluminium (AlMn)

Made of aluminium

	↔ mm		#	⊙ mm	⊥ mm		↑ mm		
	600 x 400	4 Seiten 45° / 4 sides 45°	381100	3	1,5	unbeschichtet/ uncoated	10	10	
	600 x 400	3 Seiten 90° / 3 sides 90° 1 kurze Seite offen 45° / 1 short side open	381101	3	1,5	unbeschichtet/ uncoated	20	10	
	600 x 400	4 Seiten, Ränder 90°, verschweißt 4 sides 90°	381110	–	1,5	unbeschichtet/ uncoated	20	10	
 NEW	600 x 400	4 Seiten gezogen / 4 sides deep-drawn	381108	3	1,5	unbeschichtet/ uncoated	10	10	
 NEW	600 x 400	3 Seiten 90° / 3 sides 90° 1 kurze Seite offen 45° / 1 short side open	381109	–	1,5	unbeschichtet/ uncoated	10	10	
	600 x 400	4 Seiten 45° / 4 sides 45°	381102	3	1,5	Silikon / silicone	10	10	
	600 x 400	4 Seiten 45° / 4 sides 45°	382100	–	1,5	Tyneck	10	10	
	600 x 400	4 Seiten 45° / 4 sides 45°	382110	3	1,5	Tyneck	10	10	







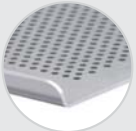

DE	BACKBLECHE
GB	BAKING TRAYS
IT	TEGLIE
ES	PLACAS

mit und ohne Lochung /
with or without perforation

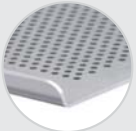
Material: Aluminium (AlMn)

Made of aluminium

5

	↔ mm		#	⊙ mm	± mm		↑ mm		
	780 x 580	2 Seiten 70° / 2 sides 70° lange Seite offen / long sides open	381005	3	2,0	unbeschichtet / uncoated	10	10	
	780 x 580	3 Seiten 90° / 3 sides 90° 1 kurze Seite offen / 1 short side open	381006	3	1,5	unbeschichtet / uncoated	25	10	
	780 x 580	3 Seiten 90° / 3 sides 90° 1 kurze Seite offen / 1 short side open	381007	3	2,0	unbeschichtet / uncoated	25	10	
	780 x 580	2 Seiten 70° / 2 sides 70° lange Seiten offen / long sides open	381200	–	2,0	unbeschichtet / uncoated	10	10	
	780 x 580	3 Seiten 90° / 3 sides 90° 1 kurze Seite offen / 1 short side open	381201	–	1,5	unbeschichtet / uncoated	25	10	
	780 x 580	4 Seiten 45° / 4 sides 45°	382200	3	1,5	Tyneck	10	10	
	980 x 580	3 Seiten 90° / 3 sides 90° 1 kurze Seite offen / 1 short side open	381000	3	1,5	unbeschichtet / uncoated	25	10	



DE	BAGUETTEBLECHE
GB	BAGUETTE TRAYS
IT	VASSOI PER BAGUETTE
ES	BANDEJAS PARA BAGUETTES



Ausführung: offener Rand – längs

Material: Aluminium
 Perforation: 1,8 mm
 Wellenform: runde Wellen

Kanten: abgerundet

Design: open edge – long side

Material: aluminium
 Perforation: 1.8 mm
 Waveform: round waves

Edges: rounded

#	↗ mm	→ mm	Mulden / muld	
381400	600	400	5	1
381401	600	400	4	1



Ausführung: offener Rand – längs

Material: Aluminium
 Perforation: 1,8 mm
 Wellenform: rund Wellen

Kanten: eckig

Design: open edge – long side

Material: aluminium
 Perforation: 1.8 mm
 Waveform: round waves

Edges: angular

#	↗ mm	→ mm	Mulden / muld	
381410	780	580	6	1



Ausführung: offener Rand – quer

Material: Aluminium
 Perforation: 1,8 mm
 Wellenform: rund Wellen

Kanten: eckig

Design: open edge – transverse side

Material: aluminium
 Perforation: 1.8 mm
 Waveform: round waves

Edges: angular

#	↗ mm	→ mm	Mulden / muld	
381420	780	580	8	1
381421	980	580	10	1
381422	980	580	12	1

DE	BEHÄLTERWAGEN	
GB	CONTAINER TROLLEY	
IT	CARRELLI PORTA CONTENITORI	
ES	CARRO PARA CONTENEDORES	

Für 8 Behälter á 25 Liter (# 200963)
 Lieferung inklusive Deckel, **ohne Behälter**

For á 8 25 litre containers (# 200963)
 Delivery including lid, **without container**

#	↗ mm	→ mm	↑ mm	
202095	670	470	1760	1



5

DE	TEIGWANNEN RECHTECKIG
GB	DOUGH CONTAINERS RECTANGULAR
IT	CONTENITORI PER IMPASTO, RETTANGOLARI
ES	BANDEJA PARA MASA, RECTANGULAR

Material: PE, weiß

made of PE, white

#	 l	↗ mm	→ mm	↑ mm	
200963	25	610	440	150	1



DE	WAGEN FÜR FAHRGESTELLE	
GB	RACK FOR TROLLEYS	
IT	TELAIO PER CARRELLI	
ES	BASTIDOR PARA CARRETILLAS	

Material: Edelstahl
 Mit je 2 Lenk- und Bockrollen

Made of stainless steel
 2 fixed and 2 steering castors

#	↗ mm	→ mm	↑ mm	
202093	760	470	1550	1



DE	FAHRGESTELL
GB	TROLLEY
IT	CARRELLO PER CONTENITORI IMPILABILI ED ISOTERMICI
ES	CARRETILLA

für alle Stapelbehälter und Isoboxen im Grundmaß 400 x 600 mm, mit je 2 Lenk- und Bockrollen

for all stacking containers and Isoboxes with 400 x 600 mm bottom dimensions, 2 fixed and 2 steering castors

#		
202092	Edelstahl / stainless steel	1
202099	rot / red	1





DE	TRANSPORTWAGEN
GB	UTILITY RACK
IT	CARRELLO
ES	CARRO



Material: Edelstahl, Rahmen aus Vierkantprofilen 25 x 25 mm; Höhe: 1,8 Meter

- Modulare Export-Ausführung
- Blecheinschub längs
- Selbstmontage, inkl. 6 Inbusschrauben und Inbusschlüssel
- Lenkrolle aus Thermoplast Ø: 100 mm
- Blechauflage: 30 mm; Materialstärke: 1 mm

Made of stainless steel, frame 25 x 25 mm; height: 1,8 m

- Modular export version
- Tray insertion lengthwise
- Self-assembly, incl. 6 screws and Allen-key
- Thermoplastic wheels 100 mm
- Sheet support: 30 mm, thickness 1 mm

#	↗ mm	→ mm	📄	🛒
385000	600	400	15	1
385010	600	400	20	1
385020	530	325	15	1
385030	530	325	20	1

📄 Stikken- und Ofenwagen für alle gängigen Öfen (MIWE, REVENT, etc.) sowie Frosterwagen auf Anfrage. / Mobile oven racks for all common ovens (MIWE, REVENT, etc.) as well as mobile freezer racks on request.



DE	KLIMASCHUTZHAUBE / GITTERHAUBE
GB	ZIPPERED PLASTIC COVER
IT	COPERTURA IN PLASTICA CON CERNIERA PER CARELLI
ES	COBRECARRITO PLASTICO

Material: LDPE mit Reißverschluss, made of LDPE with zipper
für Transport- und Stikkenwagen

#	für/for mm		↔ mm	
391950	580 x 780	längs/lengthwise	1650 x 720 x 860	1
391951	570 x 980	längs/lengthwise	1650 x 720 x 1070	1
391952	600 x 400	quer/crosswise	1600 x 690 x 450	1
391953	600 x 400	längs/lengthwise	1600 x 490 x 640	1
391954	GN 1/1 530 x 325	längs/lengthwise	1650 x 425 x 570	1



5

DE	KLIMASCHUTZHAUBE – EINWEG
GB	PLASTIC COVER – DISPOSABLE
IT	COPERTURA IN PLASTICA – USA E GETTA
ES	COBRECARRITO PLASTICO – DESECHABLE

Material: PE Made of PE
Materialstärke: 14 µ Thickness: 14 µ
Für Transport- und Stikkenwagen

#	für/for mm	Zuschnitt / blank cut	↔ mm	
391960	GN 2/1 650 x 530	100	770 / 375 x 1900	1
391961	GN 1/1 + 600 x 400	100	650 / 250 x 1850	1



#	für/for mm	Rolle / reel	↔ mm	
391970	GN 1/1 530 x 325	100	770 / 315 x 1800	1
391971	GN 2/1 650 x 530	100	770 / 375 x 1900	1
391972	600 x 400	100	650 / 250 x 1850	1



#		↔ mm	
391980	Abrollgerät / dispenser	890 x 140 x 100	1



DE	SCHNITTKUCHENBLECHE MIT VORSATZSCHIENE
GB	CAKE DISPLAY SHEET WITH JOINT BAR
IT	TEGLIE PER TORTEA TAGLIO CONLATO CORTO ESTRAIBILE
ES	BANDEJA

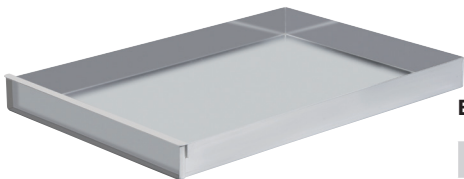
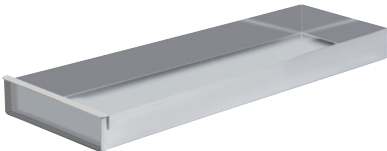
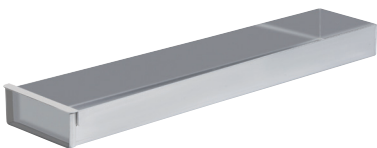

Material: Aluminium;
Materialstärke: 1,5 mm

Made of aluminium;
thickness: 1,5 mm

#	↗ mm	→ mm	↑ mm	
995810	580	100	50	10
995820	580	200	50	10
995840	580	400	50	10
995830	300	200	50	10

Ersatzschienen

Replacement joint bar

#	→ mm	für/for #	
995811	100	995810	1
995821	200	995820	1
995841	400	995840	1

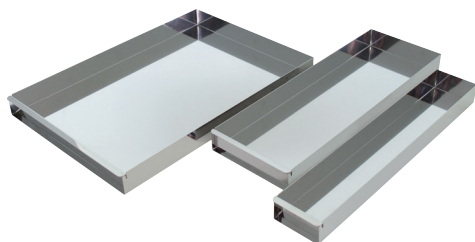

Material: Edelstahl;
Materialstärke: 1 mm

made of stainless steel;
thickness: 1 mm

#	↗ mm	→ mm	↑ mm	
997810	580	100	50	10
997820	580	200	50	10
997840	580	400	50	10

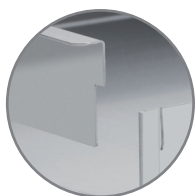

Ersatzschienen

Replacement joint bar

#	→ mm	für / for #	
997811	100	997810	1
997821	200	997820	1
997841	400	997840	1

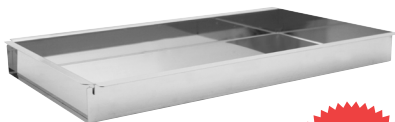

GN 1/1 mit Vorsatzschiene

Innenabmessungen: 520 x 290 x 50 mm,
Außenabmessungen: 535 x 325 x 50 mm

GN 1/1 with joint bar

dimensions inside: 520 x 290 x 50 mm,
dimensions outside: 535 x 325 x 50 mm

#			
994860	Edelstahl / stainless steel		10
995860	Aluminium / aluminium		10

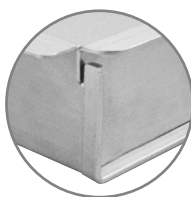

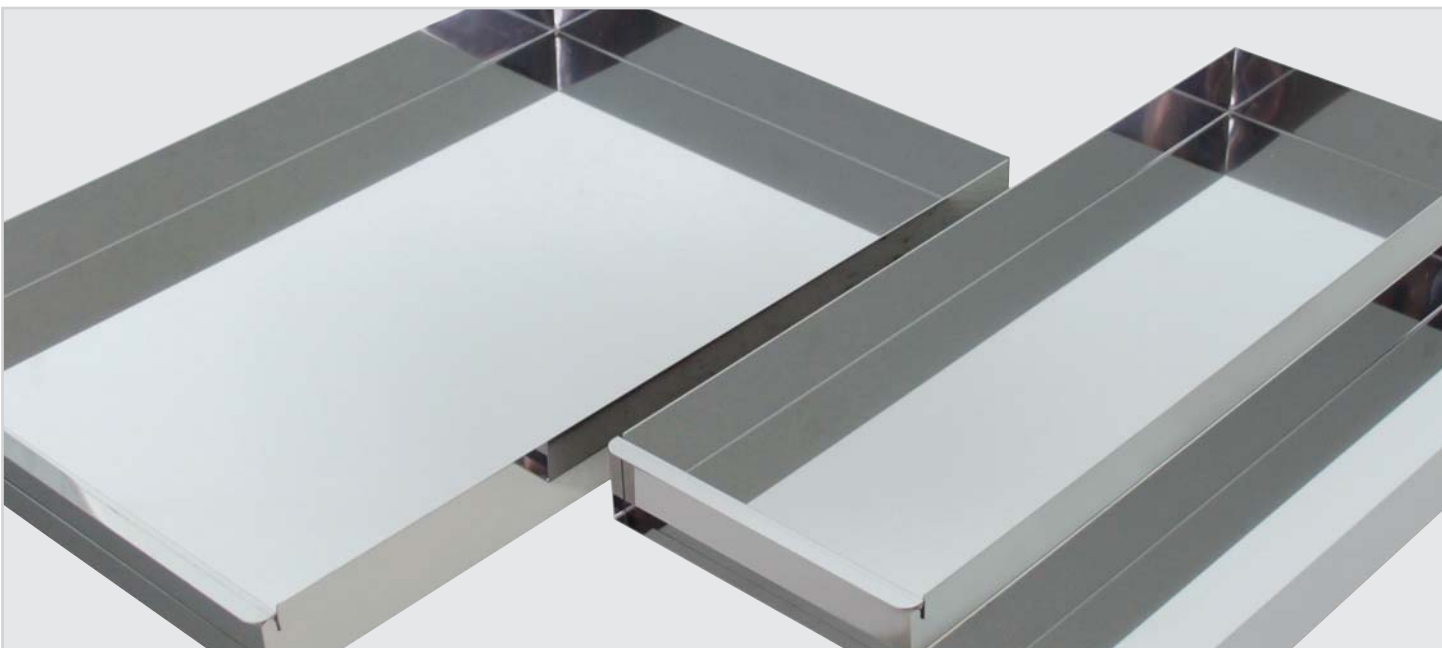

DE	BACKBLECHVORSETZER
GB	JOINT BAR, ADJUSTABLE
IT	BARRA DI GIUNZIONE REGOLABILE
ES	BARRA DE UNIÓN, AJUSTABLE

Material: Edelstahl, mit 2 Klammern

Made of stainless steel, with 2 clamps

#	↔ mm	
997899	340 min. / 615 max	1



Anwendungs-
beispiel / example



DE	SCHNITTKUCHEN – BODENBLECH UND BACKRAHMEN IM SET
GB	CAKE DISPLAY – BASE PLATE AND BAKING FRAME IN THE SET
IT	TEGLIE PER TORTEA – PIASTRA DI FONDO E TELAIO DI COTTURA IN SET
ES	BANDEJA – PLACA INFERIOR Y MARCO DE COCCIÓN COMO JUEGO

2-teilig

Material: Aluminium

Materialstärke:

Boden mit Griff: 1,5 mm, Rahmen: 2,0 mm

2-pieces

Made of aluminium;

thickness:

base with handle: 1,5 mm, frame: 2,0 mm



#	↔ mm	
995870	580 x 100	10
995880	580 x 200	10
995890	580 x 400	10





DE	BACKTRENNPAPIERE
GB	BAKING RELEASE PAPERS
IT	CARTA DA FORNO
ES	PAPEL DE HORNO SILICONADO

Echtpergament, gebleicht,
beidseitig silikonisiert, mehrmals verwendbar,
bis 290 °C, hohe Fettdichte,
geeignet für alle Gebäckarten

pure vegetable parchment, bleached,
two sides siliconized, multiple bakes,
for all baking products, heat resistant up
to 290 °C (554 °F)

“NON PLUS ULTRA”



#	↔ mm x m	⚖ g/m ²	🛒	
101040	400 x 200	45	6	
101043	430 x 200	45	6	
101045	450 x 200	45	6	
101050	500 x 200	45	6	
101057	570 x 200	45	6	

#	↔ mm x mm	⚖ g/m ²	🛒	
101100	400 x 600	45	500	
101120	500 x 700	45	500	
101140	570 x 780	45	500	

i Sonderformate auf Anfrage. / Special sizes upon request.

DE	BACKTRENNPAPIERE
GB	BAKING RELEASE PAPERS
IT	CARTA DA FORNO
ES	PAPEL DE HORNO SILICONADO

Pergamentersatz, gebleicht, beidseitig silikonisiert, mehrmals verwendbar
 greaseproof, bleached, two sides siliconized, multiple bakes

“SUPER EXTRA”

#	↔ mm x m	g/m ²	
103040	400 x 200	41	6
103043	430 x 200	41	6
103045	450 x 200	41	6
103050	500 x 200	41	6
103057	570 x 200	41	6

#	↔ mm x mm	g/m ²	
103100	400 x 600	41	500
103140	570 x 780	41	500
103150	570 x 980	41	500
103141	500 x 700	41	500

103032	320 x 530	GN 1/1	41	500
103078	520 x 640	GN 2/1	41	500



5

“UNIVERSAL”
 speziell für Laugenprodukte

especially for lyed baking products
 including “prezels”

#	↔ mm x m	g/m ²	
106057	570 x 200	41	6

#	↔ mm x mm	g/m ²	
106152	400 x 600	41	500
106140	570 x 780	41	500



DE	PERGAMENTERSATZ
GB	GREASEPROOF PAPER
IT	CARTA PERGAMINA
ES	HOJAS DE PAPEL PERGAMINO

gebleicht, unbeschichtet, zum Abdecken von Teiglingen oder als Einlegepapier für Brotkörbe verwendbar

bleached, uncoated, to cover dough or usable as inlay for baskets

#	↔ mm x mm	g/m ²	kg
111300	380 x 580	45	10
111400	360 x 560	41	12,5
111410	375 x 500	49	12,5
111420	250 x 375	49	12,5
111430	500 x 750	49	12,5

#	↔ mm	g/m ²	kg
111440	300	49	9
111441	400	49	12
111442	500	49	15
111443	600	49	18



Sonderformate auf Anfrage. / Special sizes upon request.

DE	BACKTRENNPAPIERE "RONDEN" UND "RINGREIN"
GB	BAKING RELEASE PAPERS "RONDEN" (DISCS) AND "RINGREIN"
IT	CARTA DA FORNO "RONDEN" E "RINGREIN"
ES	PAPEL DE HORNO SILICONADO "RONDEN" Y "RINGREIN"

gebleicht, beidseitig silikonisiert,
mehrmals verwendbar

bleached, siliconized on both sides,
multiple bakes

#	Ø mm	
101007	70 mm x 400 m	1
101006	180	500
101005	200	500
101011	240	500
101001	260	500
101002	280	500
101003	300	500
101004	330	500
101000	350	500



Art. 101007



zur praktischen Entnahme
– im Karton –

5



DE	BACKTRENNFOLIE AUS PTFE-GLASGEWEBE
GB	BAKING FOIL MADE OF PTFE COATED TISSUE
IT	PELLICOLA DA FORNO CON RIVESTIMENTO IN PTFE
ES	PAPEL DE HORNO ANTI-ADHERENTE

antihaftend (PTFE-beschichtetes Glasfaser-
gewebe), hervorragende Trenneigenschaften,
reißfest, temperaturbeständig von – 40 °C bis
+270 °C, beidseitig verwendbar, geschmacks-
neutral und spülmaschinenfest, bis zu 1.000 x
verwendbar (bei sachgerechter Anwendung)

non-stick quality (PTFE coated tissue),
tear-resistant, usable from –40 °C
to +270 °C, usable on both sides,
tasteless and dishwasher-proof, reusable
up to 1.000 times (by proper use)

Farbe: braun

colour: brown

#	↔ mm	⏊ mm	 g/m ²	
110110	330 x 400	0,073	120	20
110108	400 x 500	0,073	120	20
110500	400 x 600	0,073	120	20
110520	500 x 700	0,073	120	20
110540	570 x 780	0,073	120	20
110550	570 x 980	0,073	120	20
110562	600 x 800	0,073	120	20
 110116	325 x 530	0,11	220	20
110100	400 x 600	0,11	220	20
110120	500 x 700	0,11	220	20
110140	570 x 780	0,11	220	20
110150	570 x 980	0,11	220	20
110700	400 x 600	0,215	445	20
110720	570 x 780	0,215	445	20
110740	570 x 980	0,215	445	20



 Sonderformate auf Anfrage. / Special sizes upon request.



DE	BACK- UND TIEFKÜHLMATTEN
GB	BAKING AND FREEZER MATS
IT	TAPPETI DA FORNO E DA CONGELAZIONE IN SILICONE
ES	HOJAS PARA COCCIÓN Y REFRIGERACIÓN



Material: silikonbeschichtetes Glasfasergewebe, sehr robust, temperaturbeständig von -40 °C bis +300 °C, vorzügliche Antihafteigenschaft, vorteilhaft in Verbindung mit großblochigen Blechen

made of siliconized glass fibre, very strong quality, usable from -40 °C to +300 °C, excellent non-stick quality, recommended to be used in combination with baking tins with large perforation

#	↔ mm	für / for mm	
107785	315 x 520	325 x 530 (GN 1/1)	1
107782	385 x 585	400 x 600	1
107783	570 x 770	580 x 780	1

Sonderformate auf Anfrage. / Special sizes upon request.



#	↔ mm	für / for mm	
107765	315 x 520	325 x 530 (GN 1/1)	1
107762	385 x 585	400 x 600	1

DE	BACK-TRENNSPRAY FÜR FORMEN UND BLECHE
GB	RELEASE SPRAY FOR BAKING TINS AND TRAYS
IT	STACCANTE IN SPRAY ANTI ADERENTE
ES	DESMOLDEANTE EN SPRAY



Der perfekte Trennspray für Bäckereien, Konditoreien, Küchen und Gastronomie. Speziell für WALTER-Backformen geeignet. Kein Anbacken oder Ankleben der Backwaren; keine Rückstände in der Form oder auf dem Blech. Reines Lebensmittel, 100 % geschmacksneutral. Zutaten: Pflanzliche Öle; Carnaubawachs; Emulgator: Sonnenblumenlecithine; Treibgas: Propan/Butan.

Nur zur gewerblichen Verarbeitung. Nicht für Luftfracht zugelassen.

The ideal release spray for bakeries, confectioneries, hotel – and restaurant kitchens. Especially suitable for Walter Baking Moulds. Prevents baked goods from sticking to baking moulds / baking trays. 100 % safe for consumption and neutral taste. Ingredients: Vegetable Oils; Carnauba Wax; Emulsifier: Sunflower Lecithin; Propellant: Propane/Butane

For professional use only. Not permitted for transport via Airfreight.

#	ml		
266960	500	Butan/Propan	12

DE	MUFFIN-FORMEN-VERBUND „TULPE“
GB	MUFFIN TRAYS “TULIP”
IT	PLACCA PER PIROTTINI PER MUFFIN “TULIPANO”
ES	BANDEJA PARA MUFFINS “TULIPA”

Material: Aluminium
für 24 Muffinformen „TULPE“,
Ø: 70 mm, Gewicht: 1400 g

Made of aluminium
for 24 Muffin cases “TULIP”,
Ø: 70 mm, weight: 1400 g

#	↔ mm		
381150	600 x 400 x 40	1	



5

Material: Aluminium
für 24 Muffinformen „TULPE“,
Ø: 70 mm

Made of aluminium
for 24 Muffin cases “TULIP”,
Ø: 70 mm

#	↔ mm		
381151	580 x 390 x 38	1	

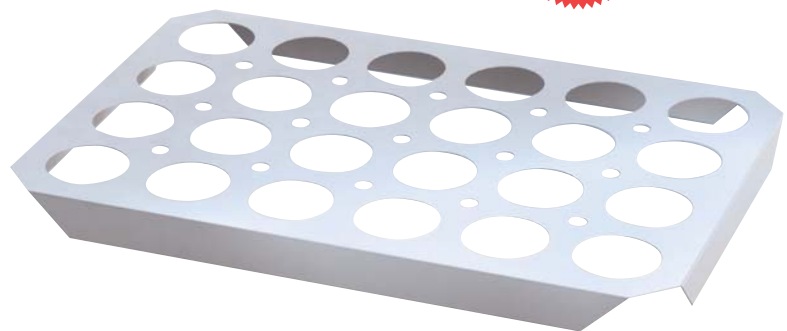

DE	MUFFIN-FORMEN-VERBUND „TULPE“
GB	MUFFIN TRAYS “TULIP”
IT	PLACCA PER PIROTTINI PER MUFFIN “TULIPANO”
ES	BANDEJA PARA MUFFINS “TULIPA”

Material: backfester Wellpappkarton
für 24 Muffinformen „TULPE“

made of bakeable cardboard
for 24 Muffin cases “TULIP”

#	↔ mm		
122260	580 x 390 x 35	42	



DE	MUFFIN-FORM „TULPE“
GB	MUFFIN "TULIP"
IT	PIROTTINI PER MUFFIN "TULIPANO"
ES	CÁPSULAS PARA MUFFINS "TULIPA"

Material: fettabweisendes Spezial-Papier
ca. 50 g/m², Boden-Ø: 50 mm
bis max. 180 °C

made of special grease proof paper
approx. 50 gr/m², bottom Ø: 50 mm
usable max. 180 °C



#		↑ mm	
122250	● Braun / brown	95	1000
122270	● Braun / brown	55	1000
122271	● Rot / red	55	1000
122272	● Gelb / yellow	55	1000
122273	● Blau / blue	55	1000
122274	● Violett / lila	55	1000
122275	● Grün / green	55	1000
122276	● Orange / orange	55	1000
122277	● Pink / pink	55	1000
122278	● Rosa / rosa	55	1000



DE	GEBÄCKKAPSELN
GB	BAKING CASES
IT	PIROTTINI MARRONI
ES	CÁPSULAS MARRONES

aus Pergamyn, Farbe schokobraun

made of glassine, colour brown



#	↓ Ø mm	↑ mm	
125018	20	18	1000
125025	25	18	1000
125028	28	16	1000
156009	50	27	1000
156008	70	30	1000

aus Pergamentersatz, backfest,
Farbe weiss

made of greaseproof paper, bakeable,
colour white



#	↓ Ø mm	↑ mm	
122018	20	18	1000
122024	25	18	1000
122035	35	20	1000
122040	40	21	1000
122045	45	25	1000
122050	50	25	1000
122055	55	25	1000
122060	60	25	1000
122065	65	22	1000
122070	70	20	1000
122075	75	21	1000
122080	80	25	1000



Art. 122100



Art. 122110

DE	MUFFINFORMEN-VERBUND
GB	MUFFIN TRAYS
IT	PLACCHE PER PIROTTINI PER MUFFIN
ES	BANDEJA DE CÁPSULAS PARA MUFFINS



Perforiert – leichte Entnahme

perforated

#	↓ Ø mm	↑ Ø mm	↔ mm	⚖ g	🛒
122100	50	68	338 x 504	2 OZ ca. / 50	125 Tray
122105	50	68	338 x 504	2 OZ ca. / 50	100 Tray
122110	63	80	385 x 575	4 OZ ca. / 100	100 Tray



Art. 122105



5

DE	BACKFORM "KÖNIGSKUCHEN"
GB	LOAF CAKE BAKING MOULD
IT	TORTIERE RETTANGOLARI PER "PLUMCAKE"
ES	MOLDE "PLUMCAKE"

Material: backfestes zweilagiges Papier, 150 g/m², Temperaturbeständig von -40°C bis +220°C

made of bakeable paper, two layers, 150 g/m², temperature resistant from -40°C to +220°C

#	↗ mm	→ mm	↑ mm	⚖ g	🛒
122400	150	65	50	200	1200
122410	200	65	45	300	600
122420	225	70	65	400	516
122430	260	50	50	500	300



DE	BACKFORMEN RUND
GB	BAKING MOULDS ROUND
IT	TORTIERE TONDE
ES	MOLDES TARTA

Material: backfestes zweilagiges Papier, 125 g/m², Temperaturbeständig von -40°C bis +220°C

made of bakeable paper, two layers, 125 g/m², temperature resistant from -40°C to +220°C

#	Ø mm	↑ mm	🛒
122700	100	30	450
122710	155	30	600
122720	155	35	540
122730	170	35	800
122740	185	30	600
122750	185	35	600
122760	210	25	660
122770	210	30	660
122780	220	40	500



Backformen Baking moulds Stampi e Tortiere antiaderenti Moldes antiadherentes

PREMIUM-QUALITÄT ANTIHAFT

- spezielle Antihaf-Beschichtung
- Erhöhung der Verschleißfestigkeit durch Einsatz keramischer Partikel
- besonders schwere Profi-Qualität
- optimale Wärmeleitung
- gleichmäßiges Backen
- obstsäurebeständig

Alle Backformen bitte grundsätzlich einfetten (kein Öl verwenden)!

Bitte beachten:

- Form leicht einfetten
- Form nicht mit spitzen und scharfen Gegenständen behandeln
- Kuchen 5–10 Min. auskühlen lassen, dann gleich aus der Form lösen
- schnelle und einfache Reinigung: mit einem Tuch und heißem Wasser unter Zusatz eines handelsüblichen Spülmittels auswaschen
- Zur Schonung der Beschichtung keine Reinigung in der Spülmaschine
- Form nicht im Froster verwenden
- nicht für Holzbacköfen geeignet
- einsetzbar bis ca. +200 °C
- zur Schonung der Beschichtung – Formen bitte nicht ohne Schutz stapeln

PREMIUM-QUALITY NON-STICK

- outstanding anti-stick properties
- wear-resistant by special coating using ceramic particles
- particularly heavy professional quality
- excellent thermal conductivity
- intensive and all around browning
- acid resistant

All baking moulds must be buttered (please do not use oil)!

Please notice:

- butter mould slightly
- never use pointed or sharp utensils
- let cake cool down for 5–10 minutes, then loosen cake out of the mould right away
- clean immediately with warm water and dry thoroughly
- not dish-washer proof
- not useable in the freezer
- not useable in wood-fired oven
- useable up to +200 °C
- to protect the coating – please do not stack baking moulds without protection



 Kinderleicht backen mit WALTER / Baking made easy with WALTER.
Informationen & Rezepte: / Information & Recipes: www.backform.de

DE	RODONFORM - MIT GLATTEM RAND
GB	RODON MOULD - WITH PLAIN RIM
IT	STAMPI AMERICANI CON BORDO LISCIO
ES	MOLDE DE KUGELHOPF - CON BORDE LISO



#	Ø mm	↑ mm	🗑️ l	🛒
901314	140	72	0,75	1
901316	160	85	1,10	1
901318	180	95	1,50	1
901320	200	105	2,05	1
901322	220	115	2,70	1
901324	240	125	3,50	1
901326	260	135	4,10	1



DE	GUGELHUPF-FORM
GB	GUGELHUPF-MOULD
IT	STAMPO PER GUGLHUPF
ES	MOLDE DE KUGELHOPF



6

#	Ø mm	↑ mm	🗑️ l	🛒
930020	200	104	2,05	1



DE	SANDKRANZFORM - MIT GLATTEM BODEN
GB	SPONGE-CAKE MOULD - WITH PLAIN BOTTOM
IT	TORTIERE SAVARIN CON FONDO LISCIO
ES	MOLDE TROIS FRÈRES - CON FONDO LISO



#	Ø mm	↑ mm	🗑️ l	🛒
926820	200	65	1,45	1
926822	220	70	1,95	1
926824	240	77	2,45	1
926826	260	82	3,10	1
926828	280	89	3,90	1



DE	FRANKFURTER KRANZFORM - MIT GERIPPTEM BODEN
GB	SPONGE-CAKE MOULD - WITH WAVY BOTTOM
IT	TORTIERE TROIS FRÈRES - CON FONDO FESTONATO
ES	MOLDE TROIS FRÈRES - CON FONDO RIZADO



#	Ø mm	↑ mm	🗑️ l	🛒
915120	200	65	1,35	1
915122	220	70	1,85	1
915124	240	77	2,35	1
915126	260	82	2,95	1
915128	280	89	3,70	1





DE	KÄSETORTENFORM - MIT GERADEM RAND
GB	CHEESE FLAN PAN - WITH STRAIGHT RIM
IT	TORTIERA TONDA - CON BORDO LISCIO
ES	MOLDE REDONDO - CON BORDE DERECHO

#	Ø mm	↑ mm	↻ l	
967028	280	40	2,30	1



DE	SPRINGFORM
GB	SPRING-CAKE MOULD
IT	STAMPI APRIBILI
ES	MOLDE TARTA DESMONTABLE

Verschluss aus rostfreiem Edelstahl

fastener made of stainless steel

#	Ø mm	↑ mm	↻ l	
900020	200	70	2,15	1
900024	240	70	3,00	1
900026	260	70	3,50	1
900028	280	70	4,05	1



DE	TEIGSCHABER / KUCHENLÖSER
GB	DOUGH SCRAPER
IT	SPATOLA
ES	ESPÁTULA

Material: PP, weiß, optimal für beschichtete Backformen

made of PP, white, ideal for non-stick baking moulds

#	↗ mm	↑ mm	
227099	220	35	1



DE	ROHRBODEN FÜR SPRINGFORMEN
GB	BOTTOM WITH DOME FOR SPRING-CAKE MOULDS
IT	FONDO CIAMBELLA PER STAMPI APRIBILI
ES	FONDO SAVARIN PARA MOLDE TARTA DESMONTABLE

#	Ø mm	
900126	260	1
900128	280	1



Zur Schonung der Beschichtung – Formen bitte nicht ohne Schutz stapeln.
To prevent from damage – please do not stack baking moulds without protection.



DE	SPRINGBLECH - KONISCH
GB	SPRING-CAKE MOULD - CONICAL
IT	STAMPI APRIBILI - CONICI
ES	MOLDE TARTA DESMONTABLE - CÓNICO

Verschluss aus rostfreiem Edelstahl

fastener made of stainless steel

#	↑ Ø mm	↓ Ø mm	↑ mm	📦 l	🛒
902028	280	260	60	3,30	1
902032	320	300	60	4,35	1



DE	KUCHENBLECH
GB	CAKE MOULD
IT	TORTIERE TONDE
ES	MOLDE REDONDO

6

#	↑ Ø mm	↓ Ø mm	↑ mm	📦 l	🛒
904024	240	200	35	1,30	1
904026	260	220	35	1,50	1
904028	280	240	35	1,80	1
904030	300	260	35	2,10	1
904032	320	280	35	2,40	1
904034	340	300	35	2,75	1
904036	360	320	35	3,05	1



DE	PIZZABLECH
GB	PIZZA MOULD
IT	STAMPI PER PIZZA
ES	MOLDE PARA PIZZA

#	↑ Ø mm	↓ Ø mm	↑ mm	📦 l	🛒
904524	240	210	25	0,90	1
904526	260	235	25	1,10	1
904528	280	250	25	1,25	1



i Nicht für Holzbacköfen geeignet! / Not suitable for wood-fired ovens.



DE	OBSTTORTENFORM - MIT GERIPPTEM RAND UND GEPRÄGTEM BODEN (SCHMAL)
GB	FRUIT FLAN PAN - WITH FLUTED RIM AND STAMPED BOTTOM
IT	TORTIERE - CON BORDO FESTONATO E FONDO GOFFRATO
ES	MOLDE TARTA - CON BORDE RIZADO Y FONDO GOFRADO

#	↑ Ø mm	↓ Ø mm	📦 l	🛒
949908	80	15	0,05	1
949910	100	15	0,09	1
949912	120	20	0,14	1
949928	280	32	1,20	1
949930	300	32	1,40	1
949932	320	32	1,60	1





DE	TORTENFORM
GB	FANCY CAKE MOULD
IT	STAMPI DA TORTA FANTASIA
ES	MOLDE TARTA FANTASÍA

#	Ø mm	↑ mm	∩ l	🛒
931524	240	79	3,00	1
931526	260	80	3,50	1



DE	HERZFORM
GB	HEART MOULD
IT	STAMPI A CUORE
ES	MOLDE CORAZÓN

#	Ø mm	↑ mm	∩ l	🛒
940025	250	61	2,60	1
940027	270	65	3,30	1



DE	WOLFSZAHNBLECH
GB	“TOOTH OF WOLF” SHEET
IT	PLACCA DA DENTI DI LUPO
ES	PLACA PARA “WOLF”

#	Ø mm	↑ mm	∩ l	🛒
920000	350	330	30	1



DE	KÖNIGSKUCHENFORM
GB	LOAF CAKE MOULD
IT	TORTIERE RETTANGOLARI
ES	MOLDE PLUMCAKE

#	→ mm	↗ mm	↑ mm	∩ l	🛒
910020	90	200	70	1,05	1
910025	100	250	70	1,45	1
910030	110	300	79	2,15	1
910035	120	350	85	3,00	1





DE	REHRÜCKENFORM
GB	RIDGED BAKING MOULD
IT	TORTIERE RETTANGOLARI FESTONATE
ES	MOLDE MEDIA CAÑA REDONDO ONDULADO

#	→ mm	↗ mm	↑ mm	📦 l	🛒
994628	110	280	60	1,35	1
994633	110	330	60	1,60	1



6

DE	IGELFORM / IGELFAMILIE
GB	"HEDGEHOG" MOULD / "HEDGEHOG" FAMILY
IT	STAMPI RICCI / FAMIGLIA DI RICCI
ES	MOLDE FORMA ERIZO / FAMILIA DE ERIZOS

#	Ø mm	↑ mm	📦 l	🛒
977708	80	30	0,075	1
977710	100	40	0,175	1
977715	150	51	0,400	1
977720	200	67	0,950	1

Set bestehend aus 4 verschiedenen Igelformen / set consisting of 4 different "hedgehog" moulds

977705	1 Set
--------	-------



DE	BRIOCHEFORM
GB	BRIOCHE MOULD
IT	STAMPI A BRIOCHE
ES	MOLDES BRIOCHE

#	Ø mm	↑ mm	📦 l	🛒
951012	120	45	0,20	1
951014	140	50	0,35	1
951016	160	60	0,55	1





Art. 965020



DE	LAMM-FORM
GB	LAMB MOULD
IT	TORTIERE "AGNELLO"
ES	MOLDE TARTA "EL BORREGO"

#	→ mm	↓ mm	↑ mm	⬇️ l	🛒
965020	210	60	150	0,6	1
967030	220	260	60	1,6	1



Art. 967030



DE	WEIHNACHTSSTERN-FORM
GB	CHRISTMAS STAR MOULD
IT	TORTIERA "STELLA DI NATALE"
ES	MOLDE "ESTRELLA DE NAVIDAD"

#	→ mm	↓ mm	↑ mm	⬇️ l	🛒
967040	150	340	65	1,7	1



DE	OSTERHASEN-FORM
GB	EASTER BUNNY MOULD
IT	TORTIERE "CONIGLIETTO DI PASQUA"
ES	MOLDE TARTA "CONEJITO DE PASCUA"

#	→ mm	↓ mm	↑ mm	⬇️ l	🛒
965000	140	60	185	0,3	1
965010	180	80	260	1,3	1





DE	LAMM-FORM
GB	LAMB MOULD
IT	TORTIERE "AGNELLO"
ES	MOLDE TARTA "EL BORREGO"

Material: vorbehandelter Stahl mit Antihftbeschichtung,
Farbe: grau, inkl. 2 Klammern

made of precoated steel with non-stick coating,
colour: grey, incl. 2 clips

KLEIN / Kopf seitwärts

SMALL / head showing to the left

#	→ mm	↓ mm	↑ mm	📦 l	🛒
968000	163	67	108	0,5	1



GROSS / Kopf gerade

LARGE / head pointing straight ahead

#	→ mm	↓ mm	↑ mm	📦 l	🛒
968010	245	80	160	1,0	1



6

DE	STÄNDER ZUM BEFÜLLEN DER LAMMFORMEN
GB	SUPPORT
IT	SUPPORTO PER IL RIPIPIAMENTO DELLA TORTIERE AGNELLO
ES	SOPORTECA MOLDESTARTA "EL BOREGO"

Material: aluminierter Stahl

made of aluminized steel

#	→ mm	↗ mm	für / for #	🛒
für kleines Lamm / for small lamb				
968020	190	386	968000	1
für großes Lamm / for large lamb				
968030	264	497	968010	1

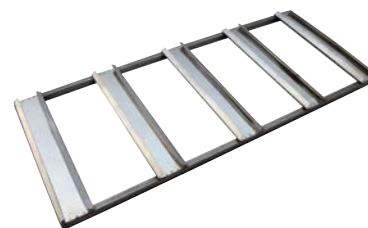

DE	LAMMFORM-SET
GB	SET OF LAMB MOULDS
IT	SET DI TORTIERE "AGNELLO"
ES	JUEGO DE MOLDES "EL BORREGO"



Komplett mit 5 Lämmern, 1 Ständer und 10 Klammern

consisting of 5 large lambs, 1 support and 10 clips

#		📦 l	🛒
968040	klein / small	0,5	1
968050	gross / large	1,0	1





DE	6-MUFFIN-FORM
GB	6-CUP MUFFIN PAN
IT	PLACCA PER 6 MUFFIN
ES	PLACA DE MOLDES PARA 6 MUFFINS

Inhalt: 90 ml

volume: 90 ml

#	Formen	↔ mm	Ø mm	
960010	6	290 x 190 x 30	62	1



DE	12-MUFFIN-FORM
GB	12-CUP MUFFIN PAN
IT	PLACCA PER 12 MUFFIN
ES	PLACA DE MOLDES PARA 12 MUFFINS

Inhalt: 90 ml

volume: 90 ml

#	Formen	↔ mm	Ø mm	
960020	12	370 x 242 x 30	62	1



DE	6-MUFFIN-FORM „HALLOWEEN“
GB	6-CUP MUFFIN PAN “HALLOWEEN”
IT	PLACCA PER 6 MUFFIN ”HALLOWEEN”
ES	PLACA DE MOLDES PARA 6 MUFFINS “HALLOWEEN”

Inhalt: 100 ml

volume: 100 ml

#	Formen	↔ mm	Ø mm	
960030	6	380 x 284 x 25	90	1



Art. 967065



Art. 967070

DE	MADELEINE
GB	MADELEINE
IT	MADELEINE
ES	MADELEINE

Material: Stahl

Made of carbon steel

#	Formen (mm)	↔ mm	
967065	12 (55 x 44)	350 x 145 x 15	1
967070	12 (77 x 52)	405 x 195 x 19	1



WALTER
...einfach besser backen...

DE	HERZFORM MIT GERIPPTEM RAND
GB	FLUTED HEART PIE
IT	STAMPO A CUORE ONDULATO
ES	TARTA DE CORAZÓN ONDULADO

#	↔ mm	↑ mm	∅ l	🛒
967075	270	30	1,1	1



WALTER
...einfach besser backen...

DE	RINGELBLUME
GB	MARIGOLD
IT	STAMPO A CALENDULA
ES	CALÉNDULA

#	↔ mm	↑ mm	∅ l	🛒
967080	260	68	2,7	1



6

WALTER
...einfach besser backen...

DE	FUSSBALLFORM
GB	FOOTBALL MOULD
IT	STAMPO A FORMA DI PALLONE DI CALCIO
ES	MOLDE DE LA TORTA DE FÚTBOL

#	∅ mm	∅ l	🛒
967050	225 mm	2,5	1



WALTER
...einfach besser backen...

DE	FUSSBALLFELD
GB	FOOTBALL FIELD
IT	STAMPO DA CAMPO DI CALCIO
ES	CAMPO DE FÚTBOL

#	↔ mm	∅ l	🛒
967060	350 x 245	3,3	1





PREMIUM-QUALITÄT EMAILLIERT

- Quarz-Email-Beschichtung
- schnitt- und kratzfest
- obstsäurebeständig

Alle Backformen bitte grundsätzlich einfetten (kein Öl verwenden)!

Bitte beachten:

- Form leicht einfetten
- Kuchen 5–10 Min. auskühlen lassen, dann gleich aus der Form lösen
- schnelle und einfache Reinigung: mit einem Tuch und heißem Wasser unter Zusatz eines handelsüblichen Spülmittels auswaschen
- Form nicht im Froster verwenden



PREMIUM-QUALITY ENAMEL

- quartz-enamel coated surface
- cut- and scratch resistant
- acid resistant

All baking moulds must be buttered (please do not use oil)!

Please notice:

- butter mould slightly
- let cake cool down for 5–10 minutes, then loosen cake out of the mould right away
- clean immediately with warm water and dry thoroughly
- do not use moulds in the freezer



DE	SPRINGFORM
GB	SPRING-CAKE MOULD
IT	STAMPI APRIBILII, SMALTATI
ES	MOLDE TARTA DESMONTABLE, ESMALTADO



emaillierter Boden, Farbe grau, schnittfest, Ring antihaft, Verschl. aus rostfreiem Edelstahl
 enamel bottom, colour grey, cut proof, non-stick, fastener made of stainless steel

#	Ø mm	↑ mm	⬇ l	🛒
980020	200	70	2,15	1
980024	240	70	3,00	1
980026	260	70	3,50	1
980028	280	70	4,05	1



Springform-Boden

emailliert, schnittfest, Farbe grau

Bottom for spring-cake mould

enamel, cut proof, colour grey

#	Ø mm	🛒
981026	260	1
981028	280	1



6

DE	KUCHENBLECH
GB	CAKE MOULD
IT	TORTIERE TONDE, SMALTATE
ES	MOLDE REDONDO, ESMALTADO



emailliert, schnittfest, Farbe schwarz max. +300°C
 enamel, cut proof, colour black max. +300°C

#	↑ Ø mm	↑ mm	⬇ l	🛒
981040	300	35	2,05	1
981041	320	35	2,35	1



DE	QUICHE-FORM
GB	"QUICHE" MOULD
IT	TORTIERA TONDA, SMALTATA, CON FONDO MOBILE
ES	MOLDE REDONDO, ESMALTADO, CON FONDO DESMONTABLE



mit praktischem Auslöseboden emailliert, schnittfest, Farbe schwarz, max. +300°C
 with exchangeable bottom enamel, cut proof, colour black, max. +300°C

#	↑ Ø mm	↑ mm	⬇ l	🛒
981050	300	30	1,80	1



DE	KASTENFORM/BROTBACKFORM
GB	BREAD MOULD
IT	STAMPI DA PANE
ES	MOLDE PARA PAN



emailliert, schnittfest, Farbe schwarz, max. +300°C
 enamel, cut proof, colour black, max. +300°C

#	→ mm	↗ mm	↑ mm	⬇ l	🛒
912030	110	300	79	2,15	1
912035	120	350	85	3,00	1



DE	KUCHEN- / QUICHE-FORMEN
GB	TART/QUICHE MOULDS
IT	TORTIERE FESTONATE, FONDO MOBILE
ES	MOLDES TARTA RIZADOS, FONDO DESMONTABLE

mit herausnehmbarem Bodenteil,
rund gewellt, mit Antihaf-Beschichtung

with removable bottom, round, fluted,
with non-stick coating



#	↑ Ø mm	↓ Ø mm	↑ mm	
995100	200	185	35	3
995101	220	200	35	3
995102	240	230	35	3
995103	260	240	35	3
995104	280	270	35	3
995105	300	280	35	3
995106	320	310	35	3

DE	TORTELETTS-FORMEN
GB	TARTLET MOULDS
IT	TARTELLETE
ES	TARTALETAS

rund gewellt, mit Antihaf-Beschichtung

round, fluted, with non-stick coating



#	↑ Ø mm	↓ Ø mm	↑ mm	
995080	60	50	10	12
995081	70	60	10	12
995082	80	70	12	12
995083	90	75	15	12
995084	100	85	18	12
995085	110	90	20	12
995086	120	110	20	12
995087	140	130	25	3

mit herausnehmbarem Bodenteil,
rund gewellt, mit Antihaf-Beschichtung

with removable bottom, round, fluted,
with non-stick coating



#	↑ Ø mm	↓ Ø mm	↑ mm	
995090	100	85	18	12
995091	110	90	20	12
995092	120	110	20	12
995093	140	130	25	3

DE	OBSTTORTENFORM
GB	FRUIT FLAN PAN
IT	TORTIERE
ES	MOLDE TARTA

Material: Aluminium, Materialstärke 1 mm Made of aluminum, 1 mm thickness

#	↑ Ø mm	↓ Ø mm	↑ mm	
997965	240	220	30	6
997966	280	260	30	6
997967	320	300	30	6
997970	220	180	45	6
997971	250	210	45	6
997972	280	240	45	6



DE	KUCHEN- / QUICHE-FORMEN
GB	TART/QUICHE MOULDS
IT	TORTIERE FESTONATE, FONDO MOBILE
ES	MOLDES TARTA RIZADOS, FONDO DESMONTABLE

Material: Aluminium, Materialstärke 1 mm Made of aluminum, 1 mm thickness

#	↑ Ø mm	↓ Ø mm	↑ mm	
997975	240	220	25	6
997976	280	260	25	6
997977	320	300	25	6



6

DE	SANDKRANZFORM - MIT GLATTEM BODEN
GB	SPONGE-CAKE MOULD - WITH PLAIN BOTTOM
IT	TORTIERE SAVARIN CON FONDO LISCIO
ES	MOLDE TROIS FRÈRES - CON FONDO LISO

Dom offen, mit gebörteltem Rand,
Material: Aluminium

open tube, with rolled edge,
made of aluminum

#	Ø mm	↑ mm	
997981	120	50	6
997982	140	53	6
997983	160	55	6
997984	180	60	6
997985	200	60	6
997986	220	70	6
997987	240	80	6
997988	260	85	6
997989	300	85	6



DE	KÖNIGSKUCHENFORM
GB	LOAF CAKE MOULD
IT	TORTIERE RETTANGOLARI
ES	MOLDE PLUMCAKE

Material: Aluminium, Materialstärke 1 mm Made of aluminum, 1 mm thickness

#	↗ mm	↑ mm	
997940	80	35	6
997941	180	58	6
997942	220	65	6
997943	260	73	6
997944	300	73	6





DE	PRALINEN-/”PETITS FOURS”-FÖRMCHEN
GB	“PETITS FOUR” MOULDS
IT	TARTELETTE
ES	TARTALETAS

Dose mit 60 Pralinenförmchen –
12 verschiedene Modelle à 5 Stück,
mit Antihaft-Beschichtung (PTFE).

box of 60 petits fours moulds,
12 different types, 5 pcs. each
with non-stick coating (PTFE).

#	Inhalt/contents	
995020	60 Stück / pieces	1



Material: elektrolytisches Weißblech

made of electrolytic tin

#	Inhalt/contents	
996020	60 Stück / pieces	1

mit Antihaft-Beschichtung (PTFE)

with non-stick coating (PTFE)



#		↔ mm	
995121	gerippter Dom/fluted dome	Ø 45	12
995122	rund, gewellt/round, wavy	Ø 45	12
995123	oval, gerippt/oval, fluted	45	12
995124	Quadrat, gewellt/square, wavy	35	12
995125	oval, gewellt/oval, wavy	45	12
995126	Raute, glatt/diamond, plain	60	12
995127	Bootform/diamond-shaped boat	60	12
995128	glatte Bootform/plain oval boat	70	12
995129	Rechteck, glatt/rectangular, plain	50	12
995130	rund, glatt/round, plain	Ø 35	12
995131	rund, glatt/round, plain	Ø 40	12
995132	rund, glatt, tief/round, plain, deep	Ø 35	12

Material: elektrolytisches Weißblech

made of electrolytic tin



#		↔ mm	
996121	gerippter Dom/fluted dome	Ø 45	12
996122	rund, gewellt/round, wavy	Ø 45	12
996123	oval, gerippt/oval, fluted	45	12
996124	Quadrat, gewellt/square, wavy	35	12
996125	oval, gewellt/oval, wavy	45	12
996126	Raute, glatt/diamond, plain	60	12
996127	Bootform/diamond-shaped boat	60	12
996128	glatte Bootform/plain oval boat	70	12
996129	Rechteck, glatt/rectangular, plain	50	12
996130	rund, glatt/round, plain	Ø 35	12
996131	rund, glatt/round, plain	Ø 40	12
996132	rund, glatt, tief/round, plain, deep	Ø 35	12

DE	SCHIFFCHEN – GLATT
GB	BOAT MOULDS – PLAIN
IT	STAMPI A BARCHETTA – LISCIE
ES	TARDALETAS BARQUITA – LISAS

ovale Form, mit Antihaf-Beschichtung (PTFE) oval shape, with non-stick coating (PTFE)

#	↗ mm	→ mm	↑ mm	
995030	70	28	10	12
995031	80	33	12	12
995032	90	40	12	12
995033	100	43	13	12
995034	110	46	13	12
995035	120	50	13	12



Material: elektrolytisches Weißblech made of electrolytic tin

#	↗ mm	→ mm	↑ mm	
996030	70	28	10	12
996031	80	33	12	12
996032	90	40	12	12
996033	100	43	13	12
996034	110	46	13	12
996035	120	50	13	12



6

DE	SCHIFFCHEN - GEWELLT
GB	BOAT MOULDS - WAVY
IT	STAMPI A BARCHETTA, FESTONATE
ES	TARDALETAS BARQUITA, RIZADAS

ovale Form, mit Antihaf-Beschichtung (PTFE) oval shape, with non-stick coating (PTFE)

#	↗ mm	→ mm	↑ mm	
995040	80	40	10	12
995042	90	43	10	12
995043	100	45	10	12
995044	110	47	13	12
995045	120	50	14	12



Material: elektrolytisches Weißblech made of electrolytic tin

#	↗ mm	→ mm	↑ mm	
996040	80	40	10	12
996042	90	43	10	12
996043	100	45	10	12
996044	110	47	13	12
996045	120	50	14	12





DE	OBSTTORTENFORM "RECHTECK"
GB	TART MOULDS "RECTANGULAR"
IT	TORTIERA FONDA "RETTANGOLARE"
ES	MOLDE FONDO "RECTANGULAR"

mit herausnehmbarem Bodenteil, gewellt, mit Antihaft-Beschichtung with removable bottom, fluted, with non-stick coating

#	↑↔ mm	↑↔ mm	↑ mm	
995107	350 x 110	340 x 100	25	3



DE	BABA-FORMEN
GB	RUM BABA MOULDS
IT	STAMPI PER BABÀ
ES	MOLDES PARA BABÀ

rund, mit geböreltem Rand, mit Antihaft-Beschichtung round, with rolled edge with non-stick coating

#	↑ Ø mm	↓ Ø mm	↑ mm	
995010	60	48	60	12



DE	ASPIK-FORMEN
GB	ASPIC MOULDS
IT	STAMPI OVALI PER ASPIC
ES	MOLDES OVALADOS PARA GELATINA DE CARNE

oval, mit geböreltem Rand, mit Antihaft-Beschichtung oval, with plain bottom, with rolled edge, with non-stick coating

#	↗ mm	→ mm	↑ mm	
995050	75	55	38	12

DE	BRIOCHE-FORMEN
GB	BRIOCHE MOULDS
IT	STAMPI A BRIOCHE
ES	MOLDES BRIOCHE

flacher Boden, mit Antihaft-Beschichtung continental style, with flat bottom, with non-stick coating



#	↑ Ø mm	↓ Ø mm	↑ mm	
995060	60	28	25	12
995061	70	37	28	12
995062	75	40	30	12
995063	80	40	32	12
995064	90	45	35	12
995065	100	55	38	12
995066	110	55	42	12

DE	PATENTFÖRMCHEN
GB	TARTLET MOULDS
IT	TARTELETTE
ES	TARDALETAS

Material: Weißblech
gedrückter Boden, gezackter Rand

made of tin, serrated edge,
stamped bottom

#	↑ Ø mm	↓ Ø mm	↑ mm	
998020	80	58	15	1
998021	100	80	15	1



DE	SAVARIN-FÖRMCHEN
GB	SAVARIN MOULDS
IT	STAMPI A CIAMBELLA
ES	MOLDES PARA SAVARIN

Dom geschlossen, mit geböteltem Rand,
mit Antihalt-Beschichtung

closed dome, with rolled edge,
with non-stick coating

#	Ø	↑ mm	
995070	65	15	12
995071	70	17	12
995072	80	20	12



Dom geschlossen, mit geböteltem Rand,
Material: Weißblech

closed dome, with rolled edge,
made of tin

#	Ø	↑ mm	
996070	65	15	12
996071	70	17	12
996072	80	20	12



Dom offen, mit geböteltem Rand,
Material: Weißblech

open dome with rolled edge,
made of tin

#	Ø	↑ mm	
996110	80	20	12
996111	120	25	3



DE	KUCHENBLECH
GB	CAKE MOULD
IT	TORTIERE TONDE
ES	MOLDE REDONDO

Material: Aluminium, Materialstärke 1 mm,
Konisch

Made of aluminum, 1 mm thickness,
conical

#	↑ Ø mm	↓ Ø mm	↑ mm	
997910	300	260	40	25
997911	320	280	40	25
997912	340	300	40	25
997913	360	320	40	25
997914	380	340	40	25
997920	320	300	50	25
997921	340	320	50	25



Backformen „AIR“ Baking moulds „AIR“ Stampi e Tortiere antiaderenti „AIR“ Moldes antiadherentes „AIR“

BACKFORMEN „AIR“

Material: **Antihftbeschichtetes Spezialgewebe**, Farbe: schwarz

- Ideal für die Herstellung von süßen und herzhaften Produkten
- Flexibles Material
- Vielfältige Funktionen
- Schnelle und einfache Anwendung
- Hohe Produktionsausbeute
- Homogenes Backen, kein Ankleben des Teiges
- Formstabil
- Vermeidet die Blasenbildung
- Optimale Luftzirkulation garantiert gleichmäßige Bräunung und ein knuspriges Ergebnis
- Bestens geeignet für Brötchen, Hamburger, Sandwiche und sämtliche Feingebäcke wie Tartletts, Brioche und vieles mehr
- Temperaturbereich: – 40 bis +260 °C (für Backöfen, Mikrowelle oder Gefrierschränke)

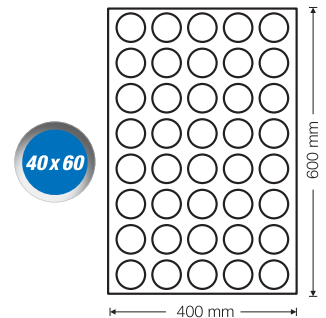

BAKING MOULDS „AIR“

Made of **perforated texture**, non-stick coated, colour: black

- Ideal for making sweet and savoury products
- Flexible material
- Multi-purpose features
- Quick and easy use
- High production yield
- Homogeneous baking, no sticking of the dough
- Dimensionally stable
- Avoids the formation of bubbles
- Optimum air circulation guarantees an even tan and a crusty result
- Ideal for buns, hamburgers, sandwiches and all pastries such as tartlets, brioche and much more
- Temperature range: from – 40 to +260 °C (for ovens, microwaves and freezers)

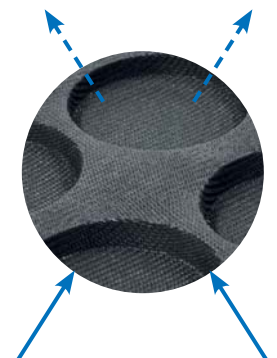

DE	HAMURGER / BUNS
GB	HAMURGER / BUNS
IT	HAMURGER / BUNS
ES	HAMURGER / BUNS



✓ #	115800
Formen/moulds	40
Ø mm	59
↑ mm	13
🛒	1

✓ #	115801
Formen/moulds	28
Ø mm	67
↑ mm	15
🛒	1

✓ #	115802
Formen/moulds	15
Ø mm	104
↑ mm	20
🛒	1

7

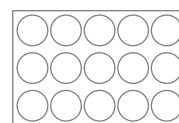
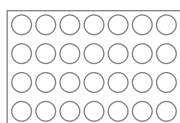
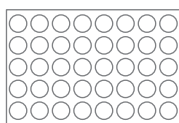

DE	HAMURGER / BUNS
GB	HAMURGER / BUNS
IT	HAMURGER / BUNS
ES	HAMURGER / BUNS

DE	BAGEL
GB	BAGEL
IT	BAGEL
ES	BAGEL

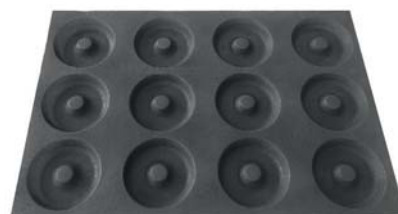

✓ #	115803
Formen/moulds	11
Ø mm	114
↑ mm	18
🛒	1

✓ #	115804
Formen/moulds	11
Ø mm	125
↑ mm	18
🛒	1

✓ #	115805
Formen/moulds	12
Ø mm	110
↑ mm	18
🛒	1

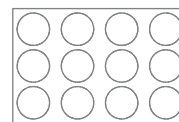
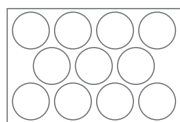
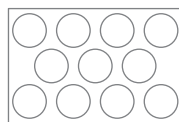



<input checked="" type="checkbox"/>	DE	MINI BAGUETTES
	GB	MINI BAGUETTES
	IT	MINI BAGUETTES
	ES	MINI BAGUETTES

NEW

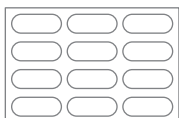

#	115806
Formen/moulds	12
↔ mm	169 x 64
↑ mm	30
	1



NEW

#	115807
Formen/moulds	10
↔ mm	200 x 64
↑ mm	30
	1

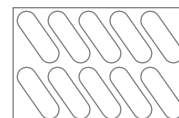

<input checked="" type="checkbox"/>	DE	MINI BAGUETTES
	GB	MINI BAGUETTES
	IT	MINI BAGUETTES
	ES	MINI BAGUETTES

NEW

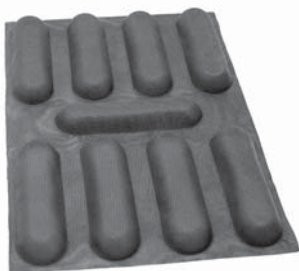

#	115808
Formen/moulds	9
↔ mm	230 x 64
↑ mm	30
	1



NEW

#	115809
Formen/moulds	8
↔ mm	259 x 64
↑ mm	30
	1





✓	DE	ECLAIRS
	GB	ECLAIRS
	IT	ECLAIRS
	ES	ECLAIRS

✓	DE	ECLAIRS
	GB	ECLAIRS
	IT	ECLAIRS
	ES	ECLAIRS

7

NEW



NEW

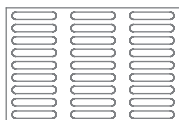

#	115810
Formen/moulds	27
↔ mm	150 x 25
↑ mm	5
🛒	1

#	115811
Formen/moulds	36
↔ mm	125 x 25
↑ mm	5
🛒	1

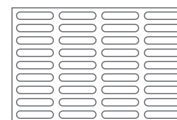

✓	DE	SANDWICH
	GB	SANDWICH
	IT	PANINO
	ES	BOCADILLO

✓	DE	SANDWICH
	GB	SANDWICH
	IT	PANINO
	ES	BOCADILLO

NEW



NEW



#	115812
Formen/moulds	8
↔ mm	240 x 70
↑ mm	35
🛒	1

#	115813
Formen/moulds	24
↔ mm	130 x 48
↑ mm	18
🛒	1

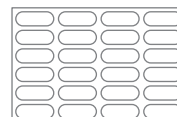

Silikon-Backformen Silicone baking moulds Stampi in silicone Moldes en silicona

BACKFORMEN AUS SILIKON 300 x 175 mm

Material: hochwertiges und lebensmittelechtes Silikon, mit Antihafteffekt – kein vorheriges Einfetten mehr notwendig!
Temperaturbereich: – 60 bis + 230 °C (für Backöfen, Mikrowelle oder Gefrierschränke)
Größe der Backformen: 175 x 300 mm (GN1/3)

Bei richtiger Anwendung sind folgende Punkte zu beachten:

- Backgut immer abkühlen lassen.
- Backformen niemals in direkten Kontakt mit Herdplatten, Feuer oder Grill bringen (am besten die Backformen auf Gitter oder Backbleche auflegen).
- Niemals das Backgut mit scharfen Gegenständen heraustrennen.
- Niemals aggressive Reinigungsmittel verwenden, sondern von Hand reinigen.

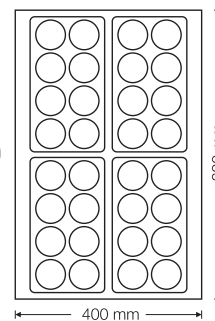

BAKING MOULDS MADE OF SILICONE 300 X 175 mm

Made of high quality, food safe and non-sticking silicone - without prior greasing!
Temperature range: from –60 to +230 °C (for ovens, microwaves and freezers)
Size of the baking moulds: 175 x 300 mm (GN 1/3)

For optimal using please note the following points:

- Let cool down the products before extraction.
- Never use baking moulds on heat sources (fire, grill, electric plates).
- Never cut your products directly in the moulds.
- Never clean the moulds with abrasive sponge or detergents.
The moulds should be washed after use, only by hand.

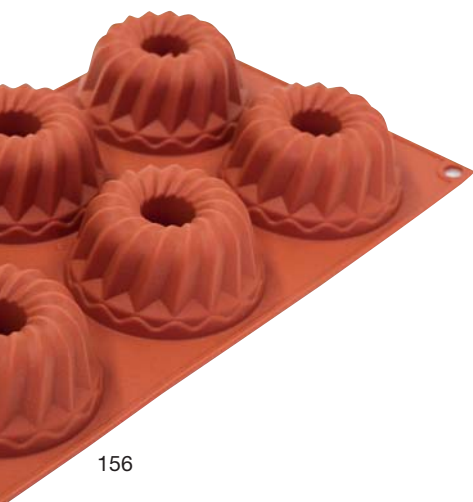
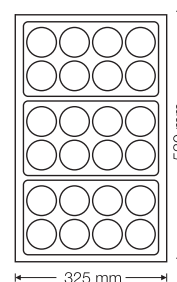

NEW

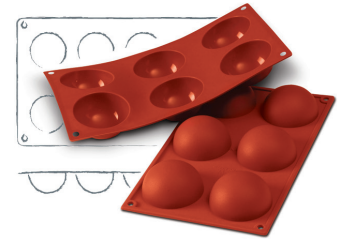
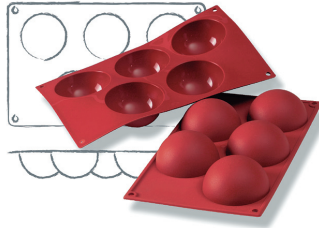

DE	HALBKUGELN MINI
GB	HALF-SPHERES MINI
IT	SEMISTERE MINI
ES	SEMIESFERAS MINI

DE	HALBKUGELN
GB	HALF-SPHERES
IT	SEMISTERE
ES	SEMIESFERAS

DE	HALBKUGELN
GB	HALF-SPHERES
IT	SEMISTERE
ES	SEMIESFERAS

#	115220
Formen/moulds	24 x 10 ml
Ø mm	30
↑ mm	15
	1

#	115003
Formen/moulds	5 x 120 ml
Ø mm	80
↑ mm	40
	1

#	115005
Formen/moulds	6 x 80 ml
Ø mm	70
↑ mm	35
	1

NEW

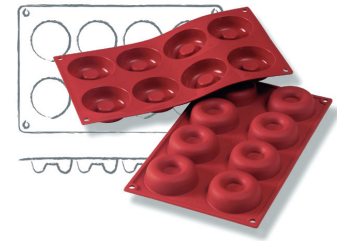
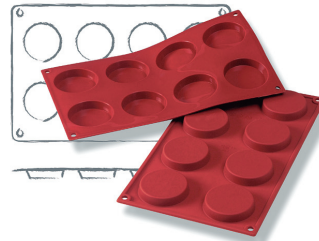

DE	FLORENTINER MINI
GB	FLORENTIN MINI
IT	FIorentINA MINI
ES	FLORENTINA MINI

DE	FLORENTINER
GB	FLORENTIN
IT	FIorentINA
ES	FLORENTINA

DE	SAVARIN
GB	SAVARIN
IT	SAVARIN
ES	SAVARIN

#	115226
Formen/moulds	24 x 5 ml
Ø mm	35
↑ mm	5
	1

#	115006
Formen/moulds	8 x 35 ml
Ø mm	60
↑ mm	12
	1

#	115007
Formen/moulds	8 x 50 ml
Ø mm	65
↑ mm	21
	1

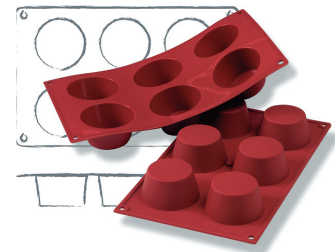
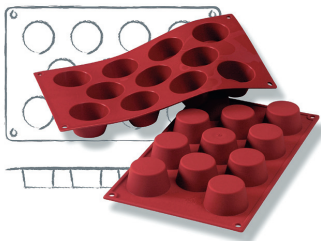

DE	MUFFIN MINI
GB	MUFFIN MINI
IT	MUFFIN MINI
ES	MUFFIN MINI

DE	MUFFIN MEDIUM
GB	MUFFIN MEDIUM
IT	MUFFIN MEDIUM
ES	MUFFIN MEDIUM

DE	MUFFIN
GB	MUFFIN
IT	MUFFIN
ES	MUFFIN

#	115012
Formen/moulds	11 x 50 ml
Ø mm	51
↑ mm	28
	1

#	115221
Formen/moulds	6 x 119 ml
Ø mm	68
↑ mm	38
	1

#	115011
Formen/moulds	6 x 100 ml
Ø mm	69
↑ mm	35
	1

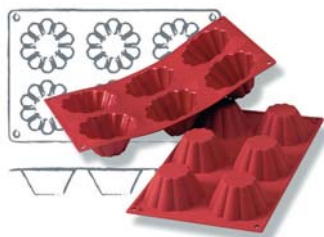

✓ DE	MUFFIN GROSS
GB	MUFFIN BIG
IT	MUFFIN GRANDE
ES	MUFFIN GORDO

✓ DE	BRIOCHE
GB	BRIOCHE
IT	BRIOCHE
ES	BRIOCHETTES

✓ DE	TORTELETT
GB	TARTLETS
IT	TARTELETTE
ES	TARTELETA GRANDE

#	115131
Formen/moulds	6 x 165 ml
Ø mm	75
↑ mm	60
🛒	1

#	115014
Formen/moulds	6 x 110 ml
Ø mm	79
↑ mm	37
🛒	1

#	115015
Formen/moulds	8 x 40 ml
Ø mm	60
↑ mm	17
🛒	1

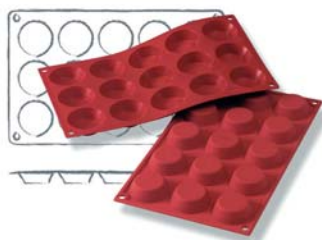

✓ DE	TORTELETT
GB	TARTLET
IT	TARTELETTE
ES	TARTITAS

✓ DE	TORTELETT MINI
GB	TARTLET MINI
IT	TARTELETTE MINI
ES	TARTITAS MINI

✓ DE	TORTELETT
GB	TARTLET
IT	TARTELETTE
ES	TARTITAS

#	115016
Formen/moulds	15 x 25 ml
Ø mm	50
↑ mm	15
🛒	1

#	115017
Formen/moulds	15 x 20 ml
Ø mm	45
↑ mm	10
🛒	1

#	115222
Formen/moulds	6 x 70 ml
Ø mm	70
↑ mm	20
🛒	1

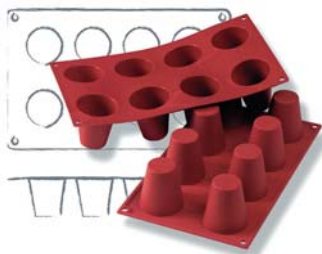

✓ DE	BABA
GB	BABA
IT	BABÀ
ES	BIZCOCHO BORRACHO

✓ DE	PYRAMIDE
GB	PYRAMID
IT	PIRAMIDE
ES	PIRAMIDE

✓ DE	PYRAMIDE
GB	PYRAMID
IT	PIRAMIDE
ES	PIRAMIDE

#	115024
Formen/moulds	8 x 92 ml
Ø mm	55
↑ mm	60
🛒	1

#	115028
Formen/moulds	6 x 90 ml
↔ mm	71 x 71
↑ mm	40
🛒	1

#	115029
Formen/moulds	15 x 20 ml
↔ mm	36 x 36
↑ mm	22
🛒	1



✓ DE	OVAL
GB	OVAL
IT	OVALI
ES	ÓVALO

✓ DE	BISCUIT
GB	BISCUIT
IT	BISQUIT
ES	BIZCOCHO

✓ DE	RECHTECK MINI
GB	FINANCIERS MINI
IT	RETTANGOLI MINI
ES	RECTÁNGULO MINI

#	115030
Formen/moulds	9 x 50 ml
↔ mm	70 x 50
↑ mm	20
🛒	1

#	115036
Formen/moulds	3 x 140 ml
Ø mm	103
↑ mm	20
🛒	1

#	115037
Formen/moulds	20 x 20 ml
↔ mm	49 x 26
↑ mm	11
🛒	1

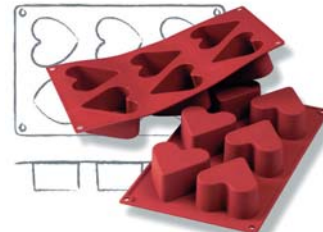
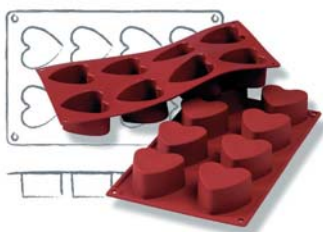

✓ DE	RECHTECK
GB	FINANCIERS
IT	RETTANGOLO
ES	RECTÁNGULO

✓ DE	HERZ
GB	HEARTS
IT	CUORE
ES	CORAZÓN

✓ DE	HERZ
GB	HEARTS
IT	CUORE
ES	CORAZÓN

#	115233
Formen/moulds	6 x 110 ml
↔ mm	120 x 45
↑ mm	20
🛒	1

#	115039
Formen/moulds	8 x 90 ml
Ø mm	60
↑ mm	35
🛒	1

#	115069
Formen/moulds	6 x 130 ml
Ø mm	65
↑ mm	40
🛒	1



✓ DE	HERZ "PASSION"
GB	HEART "PASSION"
IT	CUORE "PASSIONE"
ES	CORAZÓN "PASIÓN"

#	115090
Formen/moulds	24 x 16 ml
Ø mm	37 x 36
↑ mm	23
🛒	1

#	115091
Formen/moulds	10 x 45 ml
Ø mm	56 x 52
↑ mm	29
🛒	1

#	115092
Formen/moulds	8 x 72 ml
↔ mm	64 x 62
↑ mm	32
🛒	1

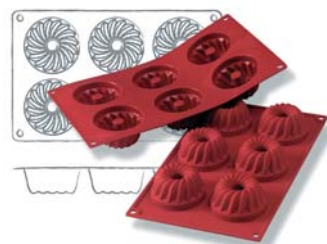

DE	GUGELHUPF MINI
GB	GUGELHOPF MINI
IT	GUGELHUPF MINI
ES	BIZCOCHO DE SABOYA MINI

DE	GUGELHUPF MEDIUM
GB	GUGELHOPF MEDIUM
IT	GUGELHUPF MEDIUM
ES	BIZCOCHO DE SABOYA MEDIUM

DE	GUGELHUPF
GB	GUGELHOPF
IT	GUGELHUPF
ES	BIZCOCHO DE SABOYA

#	115072
Formen/moulds	8 x 50 ml
Ø mm	55
↑ mm	36
	1

#	115071
Formen/moulds	6 x 80 ml
Ø mm	70
↑ mm	36
	1

#	115227
Formen/moulds	6 x 100 ml
Ø mm	75
↑ mm	40
	1



DE	VULKAN
GB	VULKANO
IT	VULCANO
ES	VOLCÁN

#	115087
Formen/moulds	24 x 16 ml
Ø mm	38,7
↑ mm	32,5
	1

#	115088
Formen/moulds	15 x 41 ml
Ø mm	52,4
↑ mm	43,7
	1

#	115089
Formen/moulds	8 x 72 ml
Ø mm	62,7
↑ mm	52
	1



DE	KUSS
GB	KISS
IT	BACIO
ES	EL BESO

DE	ROSE
GB	ROSE
IT	ROSA
ES	ROSA

#	115086
Formen/moulds	6 x 183 ml
Ø mm	74
↑ mm	66,5
	1

#	115093
Formen/moulds	15 x 23 ml
↔ mm	44
↑ mm	27
	1

#	115094
Formen/moulds	6 x 115 ml
↔ mm	76
↑ mm	40
	1

NEW

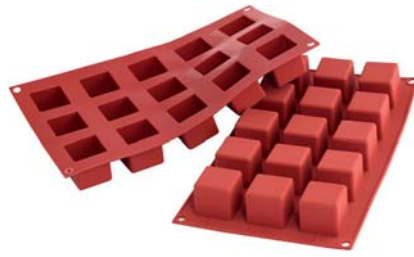

DE	KUBUS MINI
GB	CUBE MINI
IT	CUBO MINI
ES	EL CUBO MINI

DE	KUBUS
GB	CUBE
IT	CUBO
ES	EL CUBO

DE	KUBUS
GB	CUBE
IT	CUBO
ES	EL CUBO

#	115228
Formen/moulds	13 x 40 ml
→ mm	24
↑ mm	24
	1

#	115099
Formen/moulds	15 x 42 ml
↔ mm	35 x 35
↑ mm	35
	1

#	115098
Formen/moulds	8 x 125 ml
↔ mm	50 x 50
↑ mm	50
	1

7

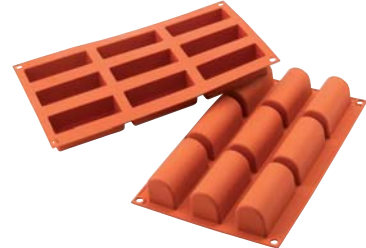
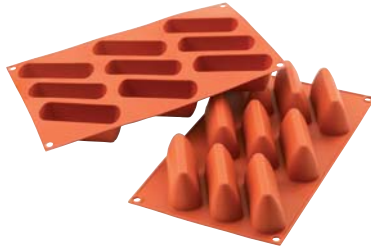
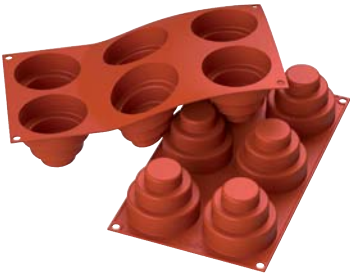

DE	MINI-KUCHEN
GB	MINI-WONDERCAKE
IT	MINITORTA
ES	EL PASTEL MINI

DE	NUSSPRALINE
GB	NUT TRUFFLE
IT	GIANDUIOTTO
ES	EL BONBÓN LA NUEZ

DE	MULDE
GB	HOLLOW
IT	TINOZZA
ES	CUBETA

#	115211
Formen/moulds	6 x 177 ml
Ø mm	59 x 29
↑ mm	70
	1

#	115212
Formen/moulds	9 x 85 ml
↔ mm	93 x 31
↑ mm	42
	1

#	115213
Formen/moulds	9 x 83 ml
↔ mm	84 x 32
↑ mm	35
	1

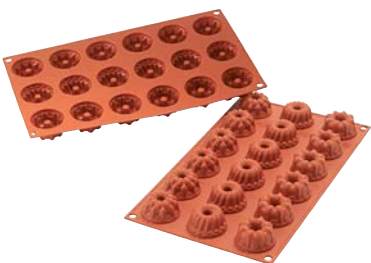

DE	MINI FANTASY
GB	MINI FANTASY
IT	MINI FANTASIA
ES	MINI FANTASY

DE	WAFFEL RUND
GB	WAFFLE ROUND
IT	CIALDA TONDA
ES	BARQUILLA REDONDO

DE	DESSERT MINI
GB	DESSERT MINI
IT	DESSERT MINI
ES	POSTRE MINI

#	115215
Formen/moulds	18 x 17,5 ml
↔ mm	40
↑ mm	22
	1

#	115217
Formen/moulds	18 x 11,5
↔ mm	40
↑ mm	12
	1

#	115076
Formen/moulds	15 x 12,3 ml
Ø mm	40
↑ mm	13
	1

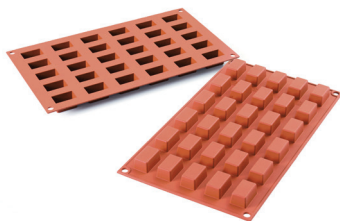

✓ DE	KUCHEN MINI
GB	CAKE MINI
IT	TORTA MINI
ES	PASTEL MINI

✓ DE	ÉCLAIR
GB	ÉCLAIR
IT	ÉCLAIR
ES	ÉCLAIR

✓ DE	ZYLINDER MINI
GB	CYLINDER MINI
IT	CILINDRO MINI
ES	CILINDROS MINI

#	115077
Formen/moulds	30 x 75 ml
↔ mm	30 x 18
↑ mm	16
🛒	1

#	115078
Formen/moulds	8 x 15 ml
↔ mm	125 x 28
↑ mm	5
🛒	1

#	115229
Formen/moulds	11 x 55 ml
Ø mm	50
↑ mm	27
🛒	1

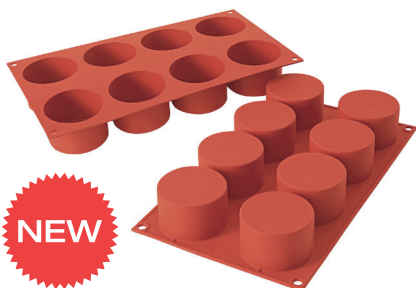

✓ DE	ZYLINDER MEDIUM
GB	CYLINDER MEDIUM
IT	CILINDRO MEDIUM
ES	CILINDROS MEDIUM

✓ DE	ZYLINDER
GB	CYLINDER
IT	CILINDRO
ES	CILINDROS

✓ DE	ZYLINDER
GB	CYLINDER
IT	CILINDRO
ES	CILINDROS

#	115231
Formen/moulds	8 x 123 ml
Ø mm	63
↑ mm	40
🛒	1

#	115230
Formen/moulds	6 x 103,5 ml
Ø mm	70
↑ mm	27
🛒	1

#	115232
Formen/moulds	6 x 133 ml
Ø mm	70
↑ mm	35
🛒	1



✓ DE	FLAN MINI
GB	FLAN MINI
IT	FLAN MINI
ES	FLAN MINI

✓ DE	FLAN MEDIUM
GB	FLAN MEDIUM
IT	FLAN MEDIUM
ES	FLAN MEDIUM

✓ DE	FLAN
GB	FLAN
IT	FLAN
ES	FLAN

#	115223
Formen/moulds	15 x 30 ml
Ø mm	50
↑ mm	14
🛒	1

#	115224
Formen/moulds	6 x 52 ml
Ø mm	70
↑ mm	17
🛒	1

#	115225
Formen/moulds	6 x 72 ml
Ø mm	80
↑ mm	18
🛒	1



7

DE	SILIKONMATTE KAFFEE
GB	COFFEE MAT
IT	TAPPETO IN SILICONE CAFFÈ
ES	ESTERA DEL CAFÉ

#	↔ mm	↑ mm	
115170	400 x 600	8,5	1



DE	SILIKONMATTE MACARONS
GB	SILICON MAT FOR MACARONS
IT	TAPPETO IN SILICONE PER MACARONS
ES	ESTERA DEL MACARONS

#	↔ mm	↑ mm	
115165	400 x 600 / Ø: 40	1,5	1



Silikon-Backformen Silicone baking moulds Stampi in silicone Moldes en silicona

BACKFORMEN AUS SILIKON 600 x 400 mm

Material: hochwertiges und lebensmittelechtes Silikon, mit Antihafteffekt – kein vorheriges Einfetten mehr notwendig!
 Temperaturbereich: – 60 bis + 230 °C (für Backöfen, Mikrowelle oder Gefrierschränke)
 Größe der Backformen: 400 x 600 mm

Bei richtiger Anwendung sind folgende Punkte zu beachten:

- Backgut immer abkühlen lassen.
- Backformen niemals in direkten Kontakt mit Herdplatten, Feuer oder Grill bringen (am besten die Backformen auf Gitter oder Backbleche auflegen).
- Niemals das Backgut mit scharfen Gegenständen heraustrennen.
- Niemals aggressive Reinigungsmittel verwenden, sondern von Hand reinigen.

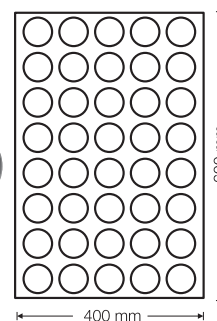

BAKING MOULDS MADE OF SILICONE 600 x 400 mm

Made of high quality, food safe and non-sticking silicone - without prior greasing!
 Temperature range: from –60 to +230 °C (for ovens, microwaves and freezers)
 Size of the baking moulds: 400 x 600 mm

For optimal using please note the following points:

- Let cool down the products before extraction.
- Never use baking moulds on heat sources (fire, grill, electric plates).
- Never cut your products directly in the moulds.
- Never clean the moulds with abrasive sponge or detergents.
 The moulds should be washed after use, only by hand.

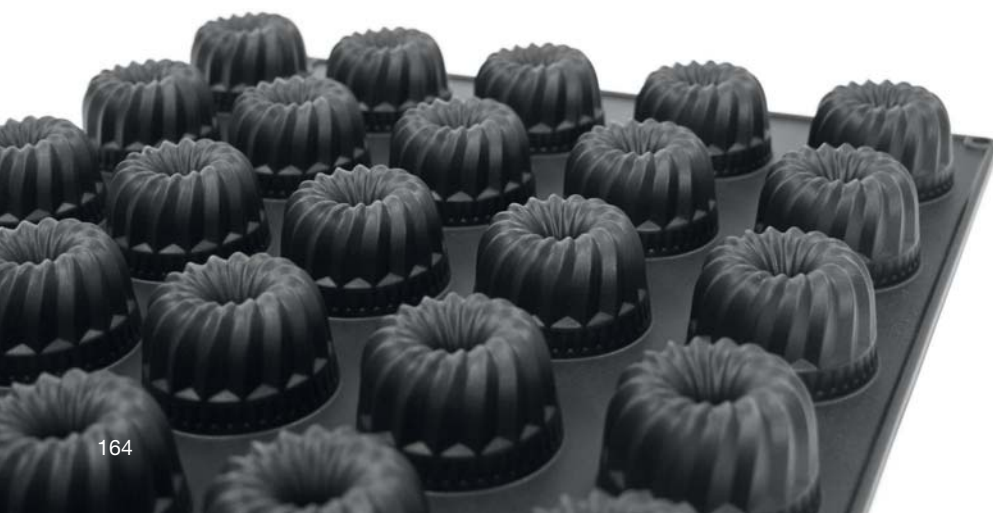

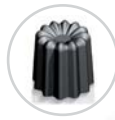

NEW

✓ DE	BRIOCHE
GB	BRIOCHE
IT	BRIOCHE
ES	BRIOCHETTE

✓ DE	CANELLE
GB	CANELLE
IT	CANELLE
ES	CANELLE

✓ DE	HALBKUGELN MINI	400 x 600 mm
GB	HALF-SPHERES MINI	
IT	SEMISTERE MINI	
ES	SEMIESFERAS MINI	

#	115300
Formen/moulds	24 x 84 ml
Ø mm	79
↑ mm	35
🍷 ml	84
🛒	1

#	115301
Formen/moulds	54 x 80 ml
Ø mm	56
↑ mm	50
🍷 ml	80
🛒	1

#	115338
Formen/moulds	96 x 11 ml
↔ mm	35
↑ mm	17,5
🍷 ml	1056
🛒	1

7



NEW

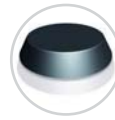

✓ DE	HALBKUGEL
GB	HALF-SPHERE
IT	SEMISFERA
ES	SEMIESFERA

✓ DE	FLORENTINER MINI
GB	FLORENTIN MINI
IT	FIORENTINA MINI
ES	FLORENTINA MINI

✓ DE	FLORENTINER	400 x 600 mm
GB	FLORENTIN	
IT	FLORENTINA	
ES	FLORENTINA	

#	115302
Formen/moulds	28 x 90 ml
Ø mm	70
↑ mm	35
🍷 ml	90
🛒	1

#	115341
Formen/moulds	70 x 15 ml
Ø mm	45
↑ mm	10
🍷 ml	1050
🛒	1

#	115303
Formen/moulds	40 x 25 ml
Ø mm	60
↑ mm	11
🍷 ml	25
🛒	1



NEW

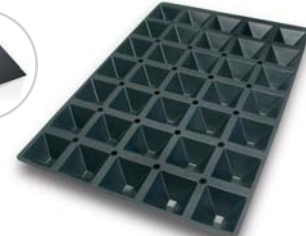
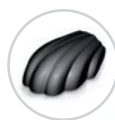

✓ DE	FLORENTINER
GB	FLORENTIN
IT	FIORENTINA
ES	FLORENTINA

✓ DE	MADELEINE
GB	MADELEINE
IT	MADELEINE
ES	MADELEINE

✓ DE	PYRAMIDE	400 x 600 mm
GB	PYRAMID	
IT	PIRAMIDE	
ES	PIRAMIDE	

#	115339
Formen/moulds	35 x 33,5 ml
Ø mm	60
↑ mm	12
🍷 ml	1172,5
🛒	1

#	115304
Formen/moulds	44 x 32 ml
Ø mm	77 x 44,5
↑ mm	18
🍷 ml	32
🛒	1

#	115305
Formen/moulds	35 x 61 ml
Ø mm	65 x 65
↑ mm	35
🍷 ml	61
🛒	1

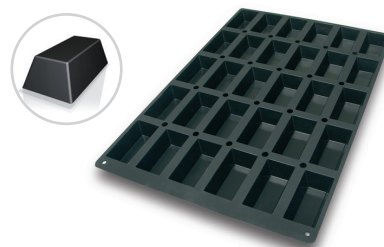
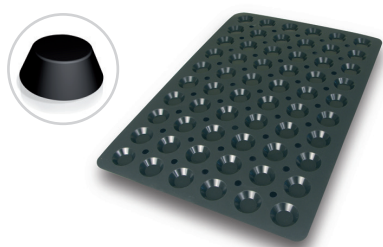

DE	TORTELETT - MINI
GB	TARTELETS - MINI
IT	TARTELETTA - MINI
ES	TARTELETA - MINI

DE	RECHTECK
GB	FINANCIERS
IT	RETTANGOLO
ES	RECTÁNGULO

#	115306
Formen/moulds	60 x 10 ml
Ø mm	44
↑ mm	10
🔄 ml	10
🛒	1

#	115342
Formen/moulds	36 x 32 ml
↔ mm	70
↑ mm	26
🔄 ml	1152
🛒	1

#	115307
Formen/moulds	30 x 130 ml
Ø mm	99 x 49
↑ mm	30
🔄 ml	110
🛒	1

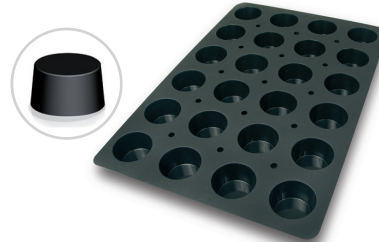
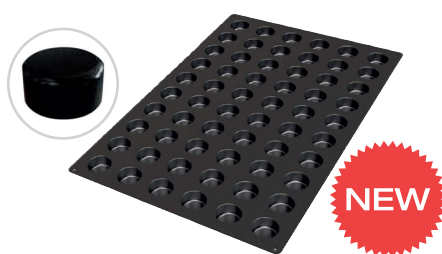
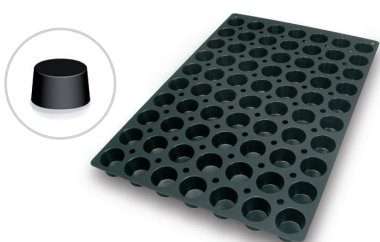

DE	MUFFIN-MINI
GB	MUFFIN-MINI
IT	MUFFIN-MINI
ES	MUFFIN-MINI

DE	MUFFIN
GB	MUFFIN
IT	MUFFIN
ES	MUFFIN

#	115309
Formen/moulds	70 x 40 ml
Ø mm	45
↑ mm	30
🔄 ml	40
🛒	1

#	115346
Formen/moulds	60 x 25 ml
Ø mm	40
↑ mm	20
🔄 ml	1500
🛒	1

#	115308
Formen/moulds	24 x 122 ml
Ø mm	69
↑ mm	39
🔄 ml	122
🛒	1

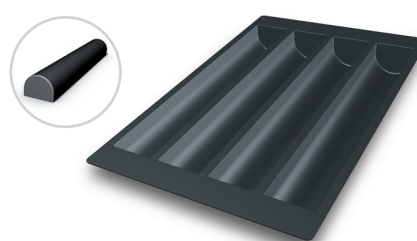

DE	GUGELHUPF
GB	GUGELHOPF
IT	GUGELHUPF
ES	BIZCOCHO DE SABOYA

DE	CREME-FORM
GB	YULE LOG
IT	TRONCO
ES	TRONCO

#	115347
Formen/moulds	35 x 80 ml
Ø mm	60
↑ mm	30
🔄 ml	2800
🛒	1

#	115310
Formen/moulds	35 x 90 ml
Ø mm	72
↑ mm	35
🔄 ml	90
🛒	1

#	115311
Formen/moulds	4 x 2137 ml
Ø mm	495 x 80
↑ mm	63
🔄 ml	2137
🛒	1



✓ DE	BISKUIT	400 x 600 mm
GB	SPONGE CAKE	
IT	PAN DI SPAGNA	
ES	BIZCOCHOS	

#	115345
Formen/moulds	15 x 341 ml
Ø mm	105
↑ mm	40
🍷 ml	5115
🛒	1

#	115313
Formen/moulds	12 x 112 ml
Ø mm	120
↑ mm	10
🍷 ml	112
🛒	1

#	115340
Formen/moulds	12 x 120 ml
Ø mm	120
↑ mm	22
🍷 ml	1440
🛒	1

7



✓ DE	BISKUIT
GB	SPONGE CAKE
IT	PAN DI SPAGNA
ES	BIZCOCHOS

✓ DE	RINNE	400 x 600 mm
GB	FLUTING	
IT	TRONCO	
ES	TRONCO RECTANGULAR	

#	115344
Formen/moulds	8 x 382 ml
Ø mm	140
↑ mm	25
🍷 ml	3056
🛒	1

#	115312
Formen/moulds	6 x 200 ml
Ø mm	160
↑ mm	10
🍷 ml	200
🛒	1

#	115315
Formen/moulds	4 x 2401 ml
↔ mm	495 x 70
↑ mm	70
🍷 ml	2400
🛒	1



✓ DE	RINNE
GB	FLUTING
IT	TRONCO
ES	TRONCO RECTANGULAR PEQUEÑO

✓ DE	FANTASY 1
GB	FANTASY 1
IT	FANTASIA 1
ES	FANTASY 1

✓ DE	FANTASY 2	400 x 600 mm
GB	FANTASY 2	
IT	FANTASIA 2	
ES	FANTASY 2	

#	115316
Formen/moulds	8 x 445 ml
↔ mm	500 x 30
↑ mm	30
🍷 ml	445
🛒	1

#	115317
Formen/moulds	28 x 103 ml
Ø mm	52 x 52
↑ mm	61
🍷 ml	103
🛒	1

#	115318
Formen/moulds	24 x 107 ml
↔ mm	117 x 29,5
↑ mm	34
🍷 ml	107
🛒	1



✓ DE	FANTASY 3
GB	FANTASY 3
IT	FANTASIA 3
ES	FANTASY 3

#	115319
Formen/moulds	24 x 103 ml
↔ mm	117 x 33
↑ mm	34
🍷 ml	103
🛒	1



✓ DE	FANTASY 4
GB	FANTASY 4
IT	FANTASIA 4
ES	FANTASY 4

#	115320
Formen/moulds	24 x 100 ml
↔ mm	117 x 29
↑ mm	39
🍷 ml	103
🛒	1



✓ DE	FANTASY 5
GB	FANTASY 5
IT	FANTASIA 5
ES	FANTASY 5

#	115321
Formen/moulds	24 x 103 ml
↔ mm	118 x 30
↑ mm	32
🍷 ml	103
🛒	1



✓ DE	FANTASY 6
GB	FANTASY 6
IT	FANTASIA 6
ES	FANTASY 6

#	115322
Formen/moulds	24 x 100 ml
↔ mm	118 x 33
↑ mm	36
🍷 ml	100
🛒	1



✓ DE	FANTASY 7
GB	FANTASY 7
IT	FANTASIA 7
ES	FANTASY 7

#	115323
Formen/moulds	24 x 104 ml
↔ mm	120 x 35
↑ mm	34
🍷 ml	104
🛒	1



✓ DE	FANTASY 8
GB	FANTASY 8
IT	FANTASIA 8
ES	FANTASY 8

#	115324
Formen/moulds	24 x 106 ml
Ø mm	120 x 36
↑ mm	33
🍷 ml	106
🛒	1



✓ DE	FANTASY 9
GB	FANTASY 9
IT	FANTASIA 9
ES	FANTASY 9

#	115325
Formen/moulds	24 x 109,5 ml
↔ mm	120 x 36,5
↑ mm	31
🍷 ml	109,5
🛒	1



✓ DE	FANTASY 10
GB	FANTASY 10
IT	FANTASIA 10
ES	FANTASY 10

#	115326
Formen/moulds	24 x 106 ml
↔ mm	120 x 35
↑ mm	30
🍷 ml	106
🛒	1



✓ DE	FANTASY 11
GB	FANTASY 11
IT	FANTASIA 11
ES	FANTASY 11

#	115327
Formen/moulds	24 x 106 ml
↔ mm	120 x 36
↑ mm	28
🍷 ml	106
🛒	1



✓ DE	FANTASY 12
GB	FANTASY 12
IT	FANTASIA 12
ES	FANTASY 12

#	115328
Formen/moulds	24 x 104 ml
↔ mm	119 x 35
↑ mm	32
🌀 ml	104
🛒	1



✓ DE	FANTASY 13
GB	FANTASY 13
IT	FANTASIA 13
ES	FANTASY 13

#	115329
Formen/moulds	24 x 100 ml
↔ mm	120 x 33
↑ mm	36
🌀 ml	103,5
🛒	1



✓ DE	FANTASY 14
GB	FANTASY 14
IT	FANTASIA 14
ES	FANTASY 14

#	115330
Formen/moulds	24 x 103 ml
↔ mm	119 x 36
↑ mm	34
🌀 ml	103
🛒	1

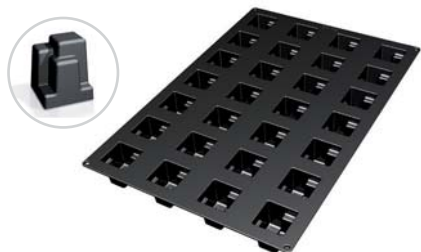

✓ DE	FANTASY 15
GB	FANTASY 15
IT	FANTASIA 15
ES	FANTASY 15

#	115331
Formen/moulds	28 x 104 ml
↔ mm	52 x 52
↑ mm	60
🌀 ml	104
🛒	1



✓ DE	FANTASY 16
GB	FANTASY 16
IT	FANTASIA 16
ES	FANTASY 16

#	115332
Formen/moulds	28 x 100 ml
↔ mm	52 x 52
↑ mm	49
🌀 ml	103
🛒	1



✓ DE	FANTASY 17
GB	FANTASY 17
IT	FANTASIA 17
ES	FANTASY 17

#	115333
Formen/moulds	28 x 102 ml
↔ mm	52 x 52
↑ mm	51
🌀 ml	102
🛒	1



✓ DE	SCHIFFCHEN
GB	BOAT
IT	BARCETTA
ES	BARQUITA

#	115334
Formen/moulds	30 x 34 ml
Ø mm	105 x 45
↑ mm	15
🌀 ml	30
🛒	1



✓ DE	ECLIPSE
GB	ECLIPSE
IT	ECLISSE
ES	ECLIPSE

#	115335
Formen/moulds	28 x 100 ml
Ø mm	70
↑ mm	35
🌀 ml	100
🛒	1



✓ DE	WAFFEL
GB	WAFFLE
IT	CIALDA
ES	BARQUILLA

#	115336
Formen/moulds	20 x 113 ml
Ø mm	95 x 70
↑ mm	24
🌀 ml	113
🛒	1



<input checked="" type="checkbox"/>	DE	ZYLINDER
	GB	CYLINDER
	IT	CILINDRO
	ES	CILINDROS

<input checked="" type="checkbox"/>	DE	HERZ
	GB	HEART
	IT	CUORE
	ES	CORAZÓN

#	115343
Formen/moulds	24 x 133 ml
Ø mm	70
↑ mm	35
ml	3192
	1

#	115348
Formen/moulds	70 x 11 ml
↔ mm	36
↑ mm	15
ml	770
	1



DE	RELIEF-MATTEN
GB	RELIEF MATS
IT	TAPPETI A RILIEVO
ES	HOJAS EN RELIEVE - RELIEVE GRIEGO PEQUEÑO

Material: Silikon, lebensmittelecht
 Für die einfache und schnelle Herstellung von Biskuit-Reliefs mit einem regelmäßigen Muster.
 Optimales Trennen vom Teig durch die hohe Antihafteigenschaft. Zum Backen und Gefrieren.
 Auch für die Herstellung von Bonbons, Nougat, Fruchtgeleeproducte etc.

made of silicone, food-safe
 To produce easily and quickly relief biscuit sheets with a regular pattern. The non-stick property allows a perfect depanning.
 The mats can be used for baking and freezing. To be used also for toffees, nougat, fruit jelly, etc.

#		↗ mm	→ mm		
107780	Griechisches Relief – Kleinmuster /greek relief, small	600	400	1	
107781	Griechisches Relief – Großmuster /greek relief, large	600	400	1	

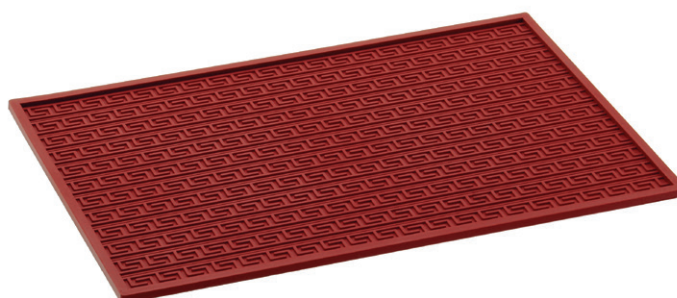



DE	FORMEN AUS SILIKON „LOLLI POP“
GB	MOULDS MADE OF SILICONE “LOLLI POP”
IT	STAMPI IN SILICONE “LOLLI POP”
ES	MOLDES EN SILICONA “LOLLI POP”

#	↔ mm	↑ mm	🔄 ml	🛒
115540	Ø 72	12	4 x 45	1
115541	75 x 67	12	4 x 31	1
115542	75,5 x 72	12	4 x 34	1
115543	Ø 74	12	4 x 40	1

7



Art. 115540

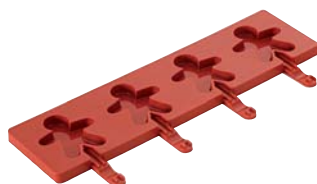

Art. 115541

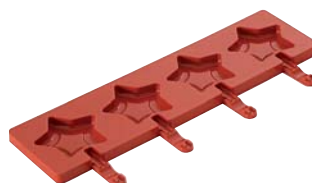

Art. 115542



Art. 115543

DE	STÄBCHEN AUS PAPPE
GB	STICKS, MADE OF CARDBOARD
IT	BASTONCINI IN CARTONE
ES	PALITOS DE CARTÓN

#	↗ mm	🛒
115548	120	50



DE	AUFNAHME / HALTERUNG
GB	HOLDER
IT	SUPPORTO
ES	SOPORTE

Material: Polycarbonat

made of polycarbonate

#	↔ mm	🛒
115549	235 x 360 x 48 mm	1



Einzelne Torten- formen aus Silikon single tart forms made of silicone



EINZELNE TORTENFORMEN AUS SILIKON

Material: hochwertiges und lebensmittelechtes Silikon, mit Antihafteffekt – kein vorheriges Einfetten mehr notwendig!
Temperaturbereich: –60 bis +230 °C (für Backöfen, Mikrowelle oder Gefrierschränke)

Bei richtiger Anwendung sind folgende Punkte zu beachten:

- Backgut immer abkühlen lassen.
- Backformen niemals in direkten Kontakt mit Herdplatten, Feuer oder Grill bringen (am besten die Backformen auf Gitter oder Backbleche auflegen).
- Niemals das Backgut mit scharfen Gegenständen heraustrennen.
- Niemals aggressive Reinigungsmittel verwenden, sondern von Hand reinigen.

SINGLE TART FORMS MADE OF SILICONE

Made of high quality and non-sticking silicone - without prior greasing!
Temperature range: from –60 to +230 °C (for ovens, microwaves and freezers)

For optimal using please note the following points:

- Let cool down the products before extraction
- Never use baking moulds on heat sources (fire, grill, electric plates).
- Never cut your products directly in the moulds.
- Never clean the moulds with abrasive sponge or detergents. The moulds should be washed after use, only by hand.

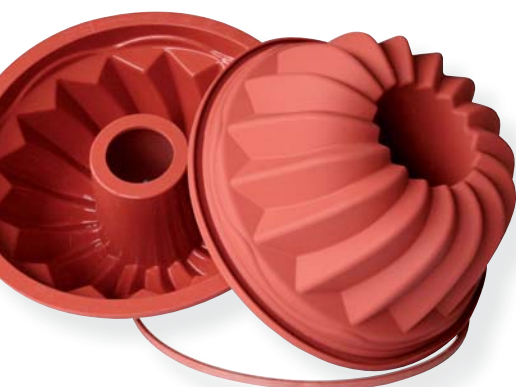



✓ DE	KÖNIGSKUCHEN		
GB	PLUM CAKE		
IT	PLUMCAKE		
ES	PLUMCAKE		

#	115050
↔ mm	240 x 105
↑ mm	65
🛒	1

#	115095
∅ mm	260 x 100
↑ mm	70
🛒	1

#	115096
↔ mm	300 x 100
↑ mm	70
🛒	1

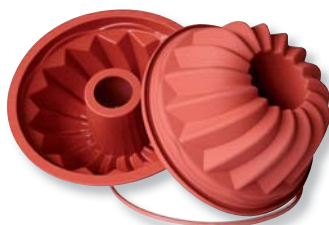

✓ DE	GUGELHUPF		
GB	GUGELHOPF		
IT	GUGELHUPF		
ES	KUGELHOPF		

#	115075
↔ mm	220
↑ mm	100
🛒	1

#	115184
↔ mm	200
↑ mm	90
🛒	1

#	115097
↔ mm	220
↑ mm	110
🛒	1



✓ DE	GLATT	
GB	PLAIN	
IT	LISCIO	
ES	REDONDO, LISO	

✓ DE	GEZACKT	
GB	SERRATED	
IT	CROSTATA	
ES	REDONDO, TARTA MANZANA CLASICA	

✓ DE	HERZ	
GB	HEART	
IT	CUORE	
ES	CORAZÓN	

#	115043	115044
↔ mm	260	280
↑ mm	45	45
🛒	1	1

#	115045	115046
↔ mm	260	280
↑ mm	30	30
🛒	1	1

#	115185
↔ mm	205 x 186
↑ mm	54
🛒	1

Silikon-Backformen Silicone baking moulds Stampi in silicone Moldes en silicona

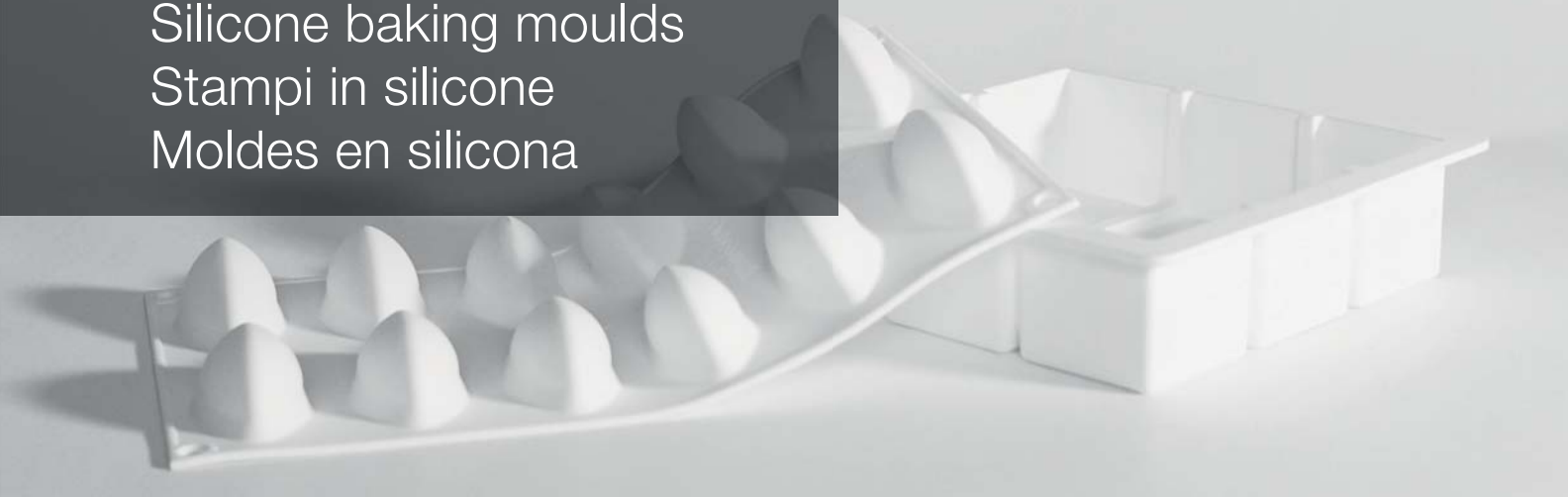

EINZELNE TORTENFORMEN AUS SILIKON

Material: hochwertiges und lebensmittelechtes Silikon, mit Antihafteffekt – kein vorheriges Einfetten mehr notwendig!
Temperaturbereich: –60 bis +230 °C (für Backöfen, Mikrowelle oder Gefrierschränke)

Bei richtiger Anwendung sind folgende Punkte zu beachten:

- Backgut immer abkühlen lassen.
- Backformen niemals in direkten Kontakt mit Herdplatten, Feuer oder Grill bringen (am besten die Backformen auf Gitter oder Backbleche auflegen).
- Niemals das Backgut mit scharfen Gegenständen heraustrennen.
- Niemals aggressive Reinigungsmittel verwenden, sondern von Hand reinigen.

SINGLE TART FORMS MADE OF SILICONE

Made of high quality and non-sticking silicone - without prior greasing!
Temperature range: from –60 to +230 °C (for ovens, microwaves and freezers)

For optimal using please note the following points:

- Let cool down the products before extraction
- Never use baking moulds on heat sources (fire, grill, electric plates).
- Never cut your products directly in the moulds.
- Never clean the moulds with abrasive sponge or detergents. The moulds should be washed after use, only by hand.





NEW



NEW



NEW

* Ring: - 60°C / + 230°C

✓ DE	TÖRTCHEN
GB	TART
IT	TARTINO
ES	TARTA

✓ DE	TÖRTCHEN
GB	TART
IT	TARTINO
ES	TARTA

✓ DE	KUBIK
GB	CUBIK
IT	CUBIK
ES	CUBIK

#	115250
Formen/moulds	6
Ø mm	80
↑ ml	50
🛒	1 Set

#	115251*
Formen/moulds	1
Ø mm	190
↑ ml	400
🛒	1 Set

#	115252
Formen/moulds	1
↔ mm	172 x 172
↑ mm	50
↑ ml	1400
🛒	1



NEW



NEW



NEW

✓ DE	ECLAIRS
GB	ECLAIRS
IT	ECLAIRS
ES	ECLAIRS

✓ DE	FANTASY
GB	FANTASY
IT	FANTASIA
ES	FANTASY

✓ DE	STEIN
GB	STONE
IT	PIETRA
ES	PIEDRA

#	115253
Formen/moulds	10
↔ mm	125
↑ mm	25
↑ ml	80
🛒	1

#	115254
Formen/moulds	12
↔ mm	63 x 29
↑ mm	28
↑ ml	24
🛒	1

#	115255
Formen/moulds	8
Ø mm	65
↑ mm	30
↑ ml	85
🛒	1



NEW



NEW

✓ DE	HERZ
GB	HEART
IT	CUORE
ES	CORAZÓN

✓ DE	TRÜFFEL
GB	TRUFFLES
IT	TARTUFI
ES	TRUFA

#	115256
Formen/moulds	8
↔ mm	63 x 65
↑ mm	39
↑ ml	100
🛒	1

#	115257
Formen/moulds	15
Ø mm	32
↑ mm	28
↑ ml	20
🛒	1

7



DE FORMEN AUS SILIKON MIT TABLETT
 GB MOULDS MADE OF SILICONE WITH TRAY
 IT STAMPI IN SILICONE CON VASSOIO
 ES MOLDES EN SILICONA CON BANDEJA

#	↔ mm	∅ mm	📦 ml	🛒
115530	300 x 400	93 x 48,5 x 25	90	1
115531	300 x 400	91 x 85 x 23	96	1



Art. 115530



Art. 115531



DE HOLZSTÄBE
 GB STICKS, MADE OF WOOD
 IT BASTONCINI IN LEGNO
 ES PALITOS DE MADERA

#	↔ mm	🛒
115539	113 x 10 x 2 mm	500

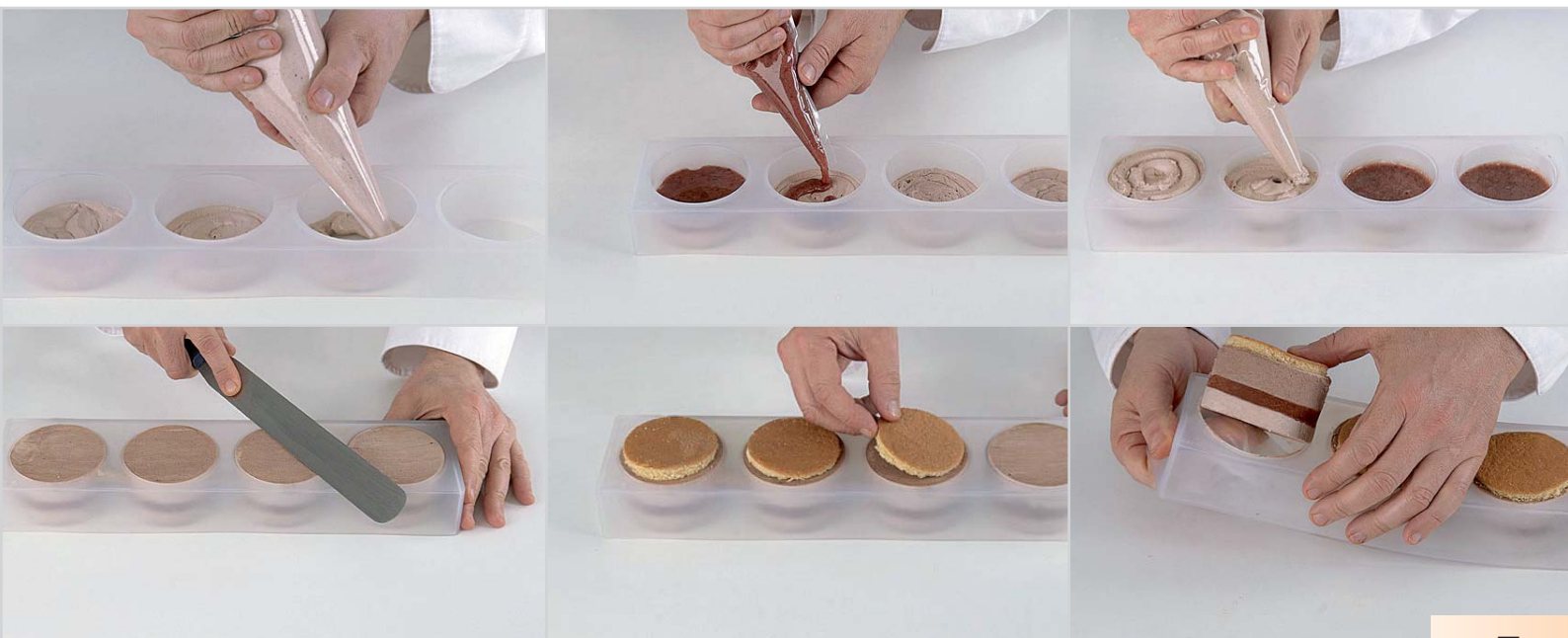

7

DE	MULTI-FORMEN AUS SILIKON MIT TABLETT
GB	MULTI MOULDS MADE OF SILICONE WITH TRAY
IT	STAMPI MULTI IN SILICONE CON VASSOIO
ES	PLACAS MULTIMOLDES EN SILICONA CON BANDEJA

#	↔ mm	∅ mm	📦 ml	🛒
115500	119 x 395 x 45	70	171 x 5 = 855	1
115501	300 x 400 x 45	70	171 x 15 = 2565	1

Art. 115500

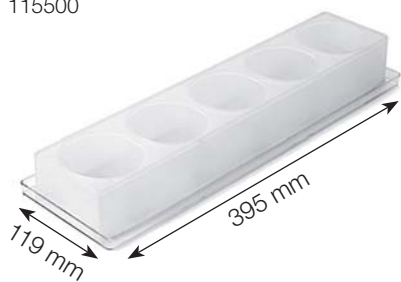

Art. 115501

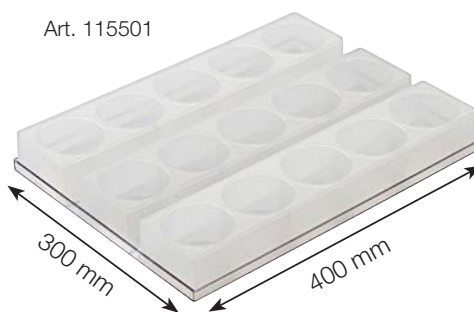

i Kunststoff-Tablett nicht ofengeeignet! / Plastic tray not suitable for ovens!



Ausstecher Cutters Tagliapasta Cortapasta



Abb. zeigt Art. 166110

DE	AUSSTECHERSÄTZE
GB	SETS OF PASTRY CUTTERS
IT	SET DI TAGLIAPASTA
ES	JUEGO DE CORTAPASTA



Material: Nylon, hitzebeständig bis +160°C
Höhe: 35 mm

made of nylon, heat resistant up to +160°C
height: 35 mm

#		Ø mm / ↔ mm		
166100	9-teilig, RUND, glatt / 9 pieces, ROUND, plain	20, 30, 40, 50, 60, 70, 80, 90, 100	1	
166101	9-teilig, RUND, gezackt / 9 pieces, ROUND, serrated	20, 30, 40, 50, 60, 70, 80, 90, 100	1	
166102	9-teilig, QUADRAT, glatt / 9 pieces, SQUARE, plain	19 / 28 / 37 / 47 / 57 / 67 / 76 / 86 / 95	1	
166103	9-teilig, QUADRAT, gezackt / 9 pieces, SQUARE, serrated	19 / 28 / 37 / 47 / 57 / 67 / 76 / 86 / 95	1	
166104	7-teilig, HERZ, glatt / 7 pieces, HEART, plain	120 x 115 / 105 x 100 / 90 x 85 / 75 x 70 / 65 x 55 / 45 x 40 / 30 x 25	1	
166105	7-teilig, HERZ, gezackt / 7 pieces, HEART, serrated	120 x 115 / 105 x 100 / 90 x 85 / 75 x 70 / 65 x 55 / 45 x 40 / 30 x 25	1	
166106	7-teilig, HALBMOND, Glatt / 7 pieces, HALF MOON, plain	69 x 20 / 80 x 28 / 90 x 35 / 98 x 43 / 100 x 50 / 110 x 58 / 114 x 65	1	
166107	7-teilig HALBMOND, gezackt / 7 pieces, HALF MOON, serrated	69 x 20 / 80 x 28 / 90 x 35 / 98 x 43 / 100 x 50 / 110 x 58 / 114 x 65	1	
166108	7-teilig, OVAL, glatt / 7 pieces, OVAL, plain	21 x 10 / 35 x 20 / 50 x 30 / 65 x 35 / 80 x 45 / 95 x 55 / 110 x 65	1	
166109	7-teilig, OVAL, gezackt / 7 pieces, OVAL, serrated	21 x 10 / 35 x 20 / 50 x 30 / 65 x 35 / 80 x 45 / 95 x 55 / 110 x 65	1	
166110	7-teilig, STERN, glatt / 7 pieces, STAR, plain	130 x 115 / 115 x 100 / 100 x 85 / 85 x 70 / 70 x 60 / 55 x 45 / 40 x 35	1	
166120	26-teilig „BUCHSTABEN“ / 26 pieces „LETTERS“	15 / 45 x 40	1	
166121	15-teilig „ZAHLEN“ / 15 pieces „NUMBERS“	15 / 60 x 45	1	



Art.-Nr. 166100



Art.-Nr. 166101

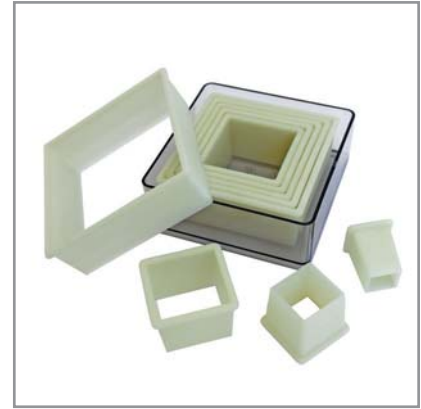

Art.-Nr. 166102



Art.-Nr. 166103



Art.-Nr. 166104



Art.-Nr. 166105



Art.-Nr. 166106



Art.-Nr. 166107



Art.-Nr. 166108



Art.-Nr. 166109



Art.-Nr. 166120



Art.-Nr. 166121



Art.-Nr. 199500



Art.-Nr. 199501



Art.-Nr. 199502



Art.-Nr. 199503



Art.-Nr. 199504



Art.-Nr. 199505



Art.-Nr. 199506



Art.-Nr. 199507



Art.-Nr. 199508



Art.-Nr. 199510



Art.-Nr. 199511

DE	AUSSTECHESSÄTZE
GB	SETS OF PASTRY CUTTERS
IT	SET DI TAGLIAPASTA
ES	JUEGO DE CORTAPASTA

Material: Edelstahl, Materialstärke: 0,4 mm, Höhe: 50 mm

made of stainless steel, thickness: 0,4 mm, height: 50 mm



Art. 199512



Art. 199513

#		Ø mm		
199512	12-teilig, RUND, glatt / 12 pieces, ROUND, plain	25, 33, 40, 48, 55, 63, 70, 76, 82, 90, 97, 105	1	
199513	12-teilig, RUND, gezackt / 12 pieces, ROUND, serrated	30, 35, 43, 48, 55, 62, 70, 75, 82, 91, 97, 103	1	



DE	AUSSTECHESSATZ (9-TEILIG), DOPPELT
GB	SET OF PASTRY CUTTERS (7 PIECES) DOUBLE
IT	SET DI TAGLIAPASTA (9 PZ.) DOPPI
ES	JUEGO DE CORTAPASTA (9 U.) DOBLES

Material: Edelstahl, Materialstärke: 0,4 – 0,5 mm, Höhe: 30 mm

made of stainless steel, thickness: 0,4 – 0,5 mm, height: 30 mm

#	Ø mm		
199520	rund, glatt und gezackt / round, plain and serrated 30, 40, 50, 60, 70, 80, 90, 98, 110	1	



DE	DONUT-AUSSTECHE
GB	DOUGHNUT CUTTERS
IT	TAGLIAPASTA PER CIAMBELLE
ES	CORTADONUTS

Material: Edelstahl

made of stainless steel

#	Ø mm	Ø mm	↓ mm		
155009	60	25	20	1	
155010	67	30	17	1	
155011	80	40	20	1	

DE	AUSSTECHERSÄTZE (9-TEILIG)
GB	SETS OF PASTRY CUTTERS (9 PIECES)
IT	SET DI TAGLIAPASTA (9 PZ.)
ES	JUEGO DE CORTAPASTA (9 U.)

Material: Edelstahl, Materialstärke: 0,4 mm, Höhe: 30 mm

made of stainless steel, thickness: 0,4 mm, height: 30 mm



Art. 199640



Art. 199641



Art. 199642



Art. 199643

#		Ø mm / ↔ mm	
199640	Raute, glatt / Diamond, plain	48/33, 59/39, 69/47, 78/55, 86/60, 98/68, 108/74, 117/83, 127/89	1
199641	Rechteck, glatt / Square, plain	25/25, 32/32, 38/38, 45/45, 50/50, 58/58, 67/67, 74/74, 82/82	1
199642	Blüte, glatt / Blossom, plain	40, 54, 67, 80, 93, 105, 118, 133, 149	1
199643	Dreieck, glatt / Triangle, plain	Seite / side: 42, 53, 61, 71, 80, 90, 103, 110, 124	1

DE	DEKOR-AUSSTECHERSÄTZE "GEMISCHTE FORMEN"
GB	SETS OF DECORATING CUTTERS "MIXED"
IT	SET DI TAGLIAPASTA "MISTI"
ES	JUEGO DE CORTAPASTA "FIGURAS VARIADAS"

Material: Edelstahl, Materialstärke: 0,3 mm, Dosendurchmesser: 100 mm

made of stainless steel, thickness: 0,3 mm, tin diameter 100 mm



Art. 199656



Art. 199657



Art. 199658

#		↑ mm	
199656	12 Stück / 12 pieces	20	1
199657	10 Stück / 10 pieces	20	1
199658	10 Stück / 10 pieces	20	1



DE	DEKOR-AUSSTECHECHERSÄTZE
GB	SETS OF DECORATING CUTTERS
IT	SET DI TAGLIAPASTA
ES	JUEGO DE CORTAPASTA

Material: Edelstahl,
Materialstärke: 0,3 mm

made of stainless steel,
thickness: 0,3 mm

#		Ø mm	↑ mm		
199650	"GEOMETRIE" 18 Stück / "GEOMETRY" 18 pieces	150	20	1	
199651	"BLUMEN" 20 Stück / "FLOWERS" 20 pieces	150	20	1	
199652	"GEMISCHTE FORMEN" 20 Stück / "MIXED" 20 pieces	150	20	1	
199653	"GEMISCHTE FORMEN" 15 Stück / "MIXED" 15 pieces	130	20	1	
199654	"GEMISCHTE FORMEN" 14 Stück / "MIXED" 14 pieces	130	20	1	
199655	"GEMISCHTE FORMEN" 15 Stück / "MIXED" 15 pieces	130	20	1	
199659	"ZAHLEN" 16 Stück / "NUMBERS" 16 pieces	100	20	1	
199660	BUCHSTABEN- UND ZAHLENAUSSTECHECHER 40 Stück / ALPHABETH AND NUMBER CUTTERS 40 pieces	150	20	1	
199661	BUCHSTABENAUSSTECHECHER 26 Stück / ALPHABETH CUTTERS 26 pieces	120	20	1	
199662	"GEOMETRIE" 24 Stück / "GEOMETRY" 24 pieces Jede Form in 3 ver. Größen / each design in three different sizes	120	20	1	
199663	"HERZ" 24 Stück / "HEART" 24 pieces Jede Form in 3 ver. Größen / each design in three different sizes	120	20	1	

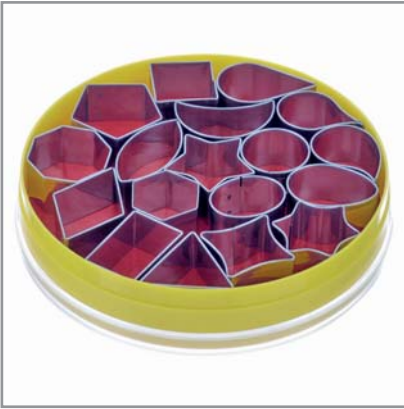

Art.-Nr. 199650

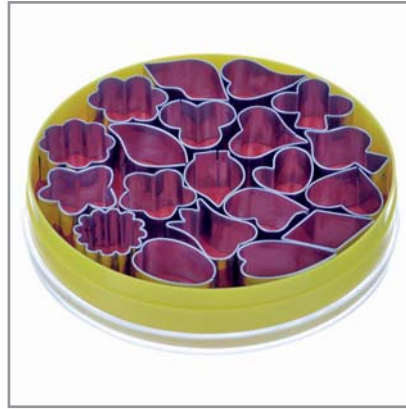

Art.-Nr. 199651

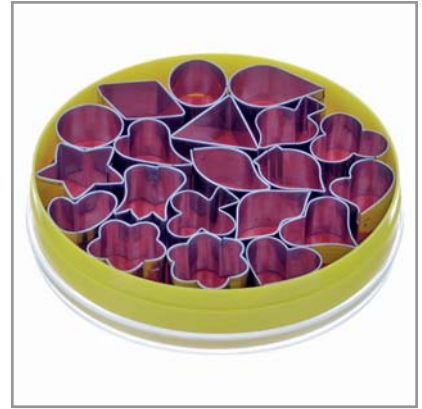

Art.-Nr. 199652



Art.-Nr. 199653



Art.-Nr. 199654



Art.-Nr. 199655



Art.-Nr. 199659



Art.-Nr. 199660



Art.-Nr. 199661



Art.-Nr. 199662



Art.-Nr. 199663



DE	DEKOR-AUSSTECHECHERSÄTZE
GB	SETS OF DECORATING CUTTERS
IT	SET DI TAGLIAPASTA
ES	JUEGO DE CORTAPASTA

Material: Edelstahl,
Materialstärke: 0,3 mm

made of stainless steel,
thickness: 0,3 mm

#		Ø mm	↑ mm		
199173	"BLUMEN" 8 Stück, mit Griff / "FLOWERS" 8 pieces, with handle	100	20	1	
199174	"GEOMETRIE" 8 Stück, mit Griff / "GEOMETRIE" 8 pieces, with handle	100	20	1	
199175	"KARTENSPIEL" 8 Stück, mit Griff / "CARDS" 8 pieces, with handle	100	20	1	
199176	"GEOMETRIE" 15 Stück / "GEOMETRIE" 15 pieces	160	20	1	
199177	"TIERE" 12 Stück / "ANIMALS" 12 pieces	160	20	1	
199178	"NIKOLAUS" 3 Stück / "SANTA CLAUS" 3 pieces	100	20	1	
199179	"TANNEN" 3 Stück / "CHRISTMAS TREES" 3 pieces	100	20	1	
199180	"KREUZE" 5 Stück / "CROSSES" 5 pieces	100	20	1	
199181	"GLOCKEN" 5 Stück / "JINGLE BELL" 5 pieces	100	20	1	
199182	"SCHNEEFLOCKE" 5 Stück / "SNOWFLAKE" 5 pieces	100	20	1	
199183	"GEMISCHTE FORMEN" 15 Stück / "MIXED" 15 pieces	100	20	1	
199184	"BLUMEN" 15 Stück / "FLOWERS" 15 pieces	100	20	1	



Art.-Nr. 199173



Art.-Nr. 199174



Art.-Nr. 199175



Art.-Nr. 199176



Art.-Nr. 199177



Art.-Nr. 199178



Art.-Nr. 199179



Art.-Nr. 199180



Art.-Nr. 199181



Art.-Nr. 199182



Art.-Nr. 199183



Art.-Nr. 199184



DE	PETIT-FOURS-AUSSTECHECHERSATZ
GB	SET OF PETIT-FOURS-CUTTERS
IT	SET DI TAGLIAPASTA (9 PZ.) "PETIT FOUR"
ES	JUEGO DE CORTAPASTA (9 U.) "PETIT FOUR"

Material: Edelstahl, 9-teilig

made of stainless steel, 9 pieces

#			
199530	Arche, Kurve, Diamant, Herz, Oval Oval rund, Rund, Rechteck, Quadrat / arch, curve, diamond, heart, oval oval round, round, rectangle, square	1	

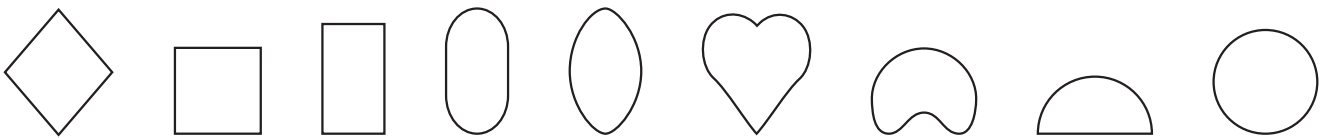

DE	ZIMTSTERN-AUSSTECHECHER
GB	CINNAMON STAR CUTTER
IT	TAGLIAPASTA "STELLA"
ES	CORTAPASTA "ESTRELLA"

Material: Edelstahl, stabiler Griff,
Federmechanismus

made of stainless steel, solid handle, spring
mechanism

#	↔ mm	↑ mm		
199584	50	97	1	

DE	GARNIER-AUSSTECHEKERSÄTZE
GB	SETS OF DECORATING CUTTERS
IT	SET DI TAGLIAPASTA
ES	JUEGOS DE CORAPASTAS

Material: Edelstahl, Materialstärke: 0,4 – 0,5 mm,
 Höhe: 30 mm
 Set besteht aus je 3 verschiedenen Größen

made of stainless steel,
 thickness: 0,4 – 0,5 mm, height: 30 mm
 each set consisting of 3 different sizes

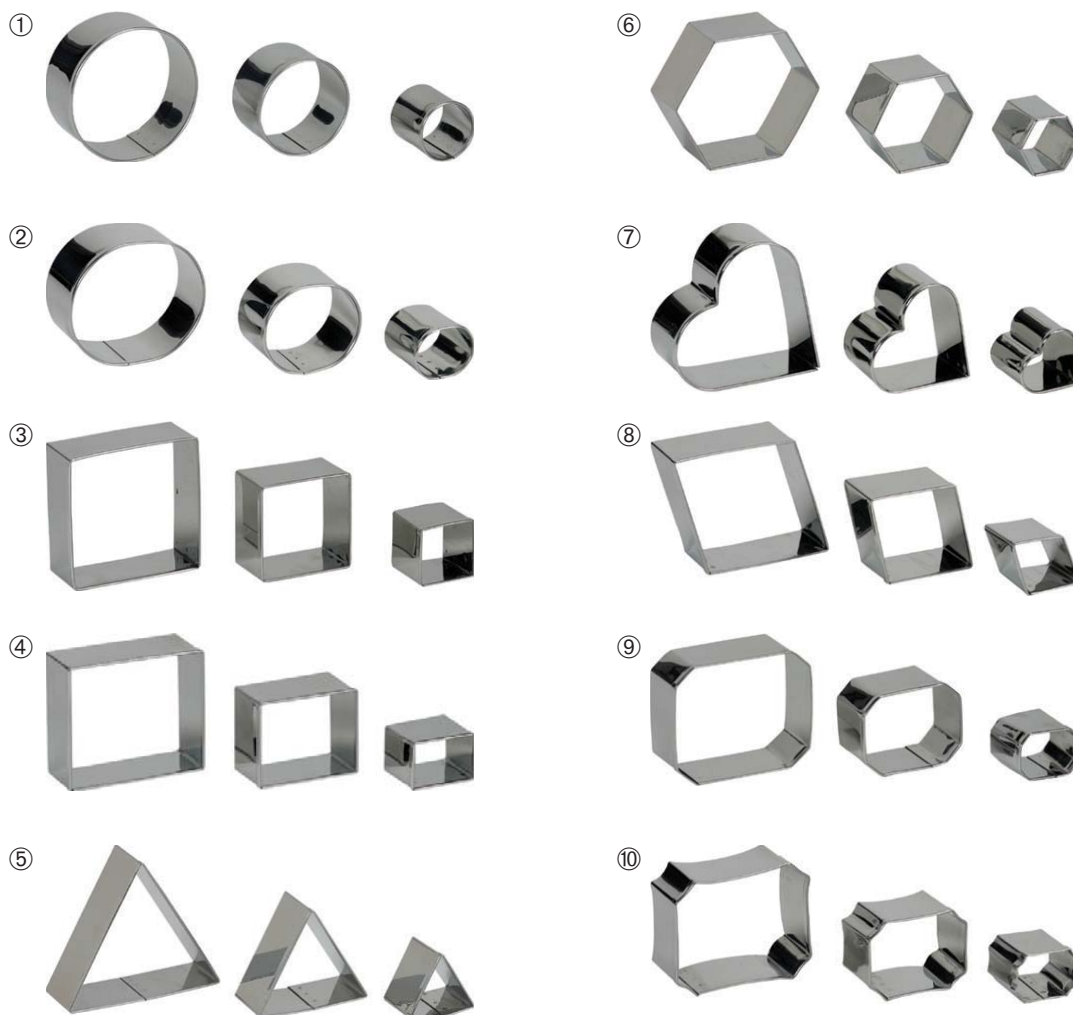

#	Nr./no.		↔ mm	
199540	1	Rund/round	30, 50 und 70	1
199541	2	Oval/oval	25 x 35, 48 x 55, 65 x 75	1
199542	3	Quadrat/square	30 x 30, 50 x 50, 65 x 65	1
199543	4	Rechteck/rectangle	25 x 35, 45 x 55, 65 x 75	1
199544	5	Dreieck/triangle	35, 60, 85	1
199545	6	Sechseck/hexagon	35, 55, 80	1
199546	7	Herz/heart	35, 60, 85	1
199547	8	Diamant/diamond	50, 80, 110	1
199548	9	Achteck/octagon	25 x 35, 45 x 55, 65 x 75	1
199549	10	Achteck gebogen/octagon curved	25 x 30, 38 x 54, 60 x 75	1

DE	AUSSTECHEMATTEN
GB	CUTTING SHEETS
IT	PLACCHE PER PASTAFROLLA
ES	PLACAS CORTAPASTA

aus hochschlagfestem Kunststoff,
 lebensmittelneutral, geruchlos, scharfkantig,
 leicht zu säubern
 Aussenabmessungen: 580 x 390 mm

made of white, impact resistant polystyrene,
 odourless, warranted free of substances,
 sharp-edged, easy to clean.
 Outer dimensions; 580 x 390 mm

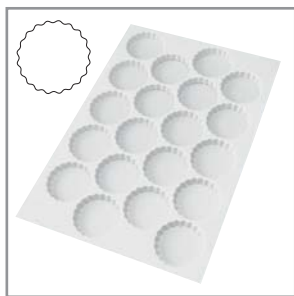

Art.-Nr. 166001 1



Art.-Nr. 166002 2

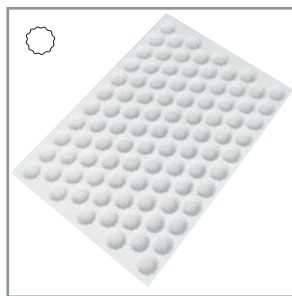

Art.-Nr. 166022 2a

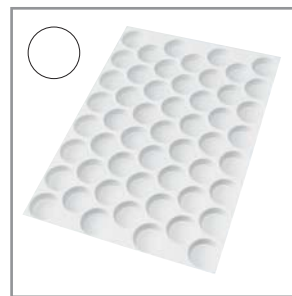

Art.-Nr. 166003 3

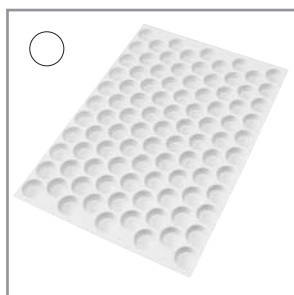
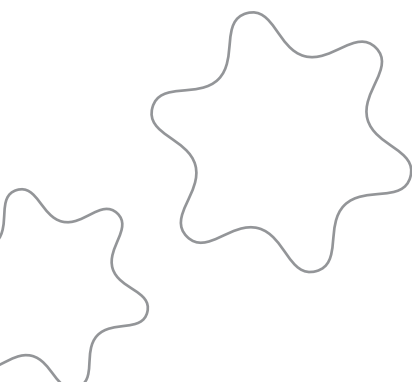

Art.-Nr. 166023 3a



Art.-Nr. 166004 4



Art.-Nr. 166024 4a

#	Nr. / no.	Ø mm		Nutz. / pcs.		
166001	1	90	rund gezackt / round, serrated	20	1	
166002	2	45	rund gezackt / round, serrated	72	1	
166022	2a	35	rund gezackt / round, serrated	90	1	
166003	3	53	rund, glatt / round, plain	53	1	
166023	3a	35	rund, glatt / round, plain	95	1	
166004	4	45	Stern / star	63	1	
166024	4a	35	Stern / star	95	1	
166005	5	50	Kleeblatt / cloverleaf	63	1	
166025	5a	35	Kleeblatt / cloverleaf	105	1	
166006	6	45	Herz / heart	95	1	
166026	6a	35	Herz / heart	116	1	
166007	7	48	Halbmond / half moon	78	1	
166027	7a	35	Halbmond / half moon	128	1	
166008	8	48	Dreiblatt / threefold sheet	68	1	
166028	8a	35	Dreiblatt / threefold sheet	105	1	
166009	9	80 / 66	Tanne, Komet / fir tree, comet	50	1	
166010	10	60	Tropfen „Munzenmandeln“ / drop	36	1	
166030	10a	51	Tropfen „Munzenmandeln“ / drop	80	1	
166031	11	60	Taube / dove	50	1	
166032	12	60	Glocke / bell	55	1	
166029	13	92	Küicken, Hase / chick, rabbit	64	1	
166033	14	80 / 75	Kamel, Elefant / camel, elephant	16 / 20	1	
166034	15	63 / 65	Apfel, Birne / appel, pear	25 / 20	1	
166035	16	68 / 78	Schildkröte, Seepferd / turtle, sea horse	20 / 20	1	
166036	17	72 / 70	Vogel, Ente / bird, duck	28 / 25	1	
166037	18	70 / 75	Seehund, Pinguin / seal, penguin	25 / 16	1	



Art.-Nr. 166005 5

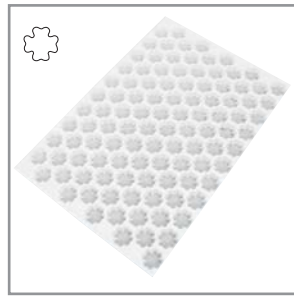

Art.-Nr. 166025 5a



Art.-Nr. 166006 6



Art.-Nr. 166026 6a



Art.-Nr. 166007 7

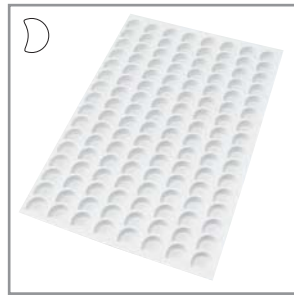

Art.-Nr. 166027 7a



Art.-Nr. 166008 8



Art.-Nr. 166028 8a



Art.-Nr. 166009 9

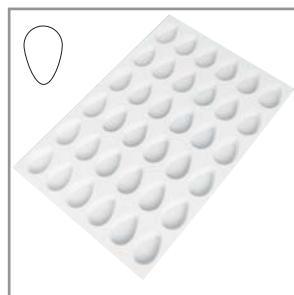

Art.-Nr. 166010 10

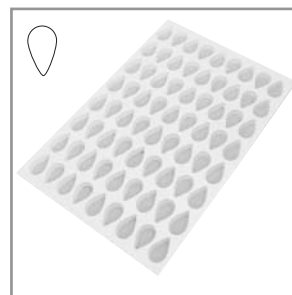

Art.-Nr. 166030 10a

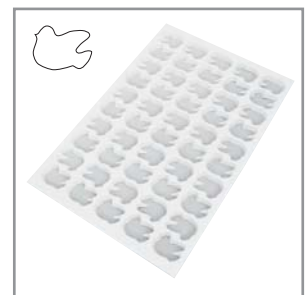

Art.-Nr. 166031 11

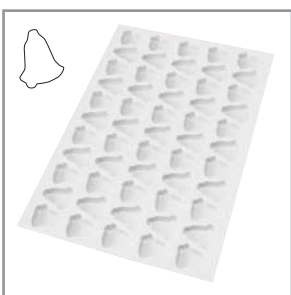

Art.-Nr. 166032 12



Art.-Nr. 166029 13

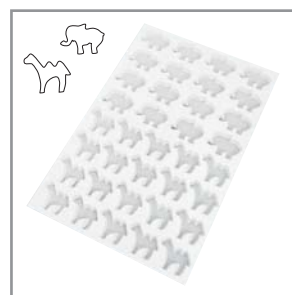

Art.-Nr. 166033 14



Art.-Nr. 166034 15



Art.-Nr. 166035 16



Art.-Nr. 166036 17



Art.-Nr. 166037 18

DE	AUSSTECHEK
GB	CUTTERS
IT	TAGLIAPASTA
ES	CORTAPASTA

Material: Edelstahl

made of stainless steel

#		Ø mm / ↔ mm	↑ mm		
199700	rund, glatt / round, plain	Ø 120	30	1	
199710	rund, glatt / round, plain	Ø 140	30	1	
199720	rund, gezackt / round, serrated	Ø 120	30	1	
199730	rund, gezackt / round, serrated	Ø 140	30	1	
199740	rund, gezackt / round, serrated	Ø 145	30	1	
199750	quadrat, gezackt / square, serrated	85 x 85	45	1	
199880	“STERN” / “STAR”	90	45	1	
199881	“STERN” / “STAR”	180	45	1	
199882	“STERN” / “STAR”	220	45	1	
199883	“HERZ” / “HEART”	70 x 63	30	6	
199884	“KOMMA” / “TEAR DROP”	90 x 60	30	1	
199885	“DREIECK KONVEX” / “CONVEX TRIANGLE”	70 x 70	30	1	
199887	“HERZ” / “HEART”	Ø 90	20	1	
199888	“BLÜTE” / “BLOSSOM”	Ø 91	20	1	
199890	“EI” / “EGG”	155 x 100	30	1	
199891	“EI” / “EGG”	190 x 125	30	1	
199150	“BANANE” / “BANANA	160		1	
199851	“RENNENDER HASE” / “RUNNING RABBIT”	175 x 85	30	1	
199852	“EIER” Ausstecher-Set / “EGG” Cutter-Set”	60 / 80 / 100 / 125	30	SET	
199853	“ARONSTAB” Ausstecher / “ARUM LILY”-Set	7-tlg. / 7 pcs.	12,5	SET	

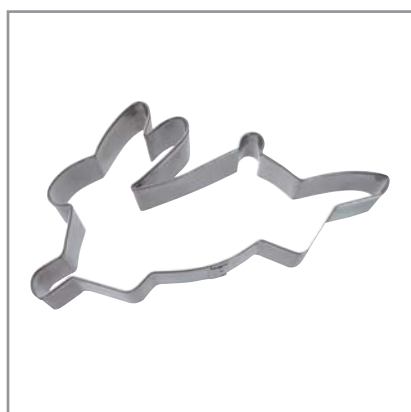

Art.-Nr. 199851



Art.-Nr. 199852



Art.-Nr. 199853



Art.-Nr. 199700 / 199710



Art.-Nr. 199720 / 199730



Art.-Nr. 199740



Art.-Nr. 199750



Art.-Nr. 199880 / 199881 / 199882



Art.-Nr. 199883



Art.-Nr. 199884



Art.-Nr. 199885



Art.-Nr. 199887



Art.-Nr. 199888



Art.-Nr. 199890 / 199891



Art.-Nr. 199150

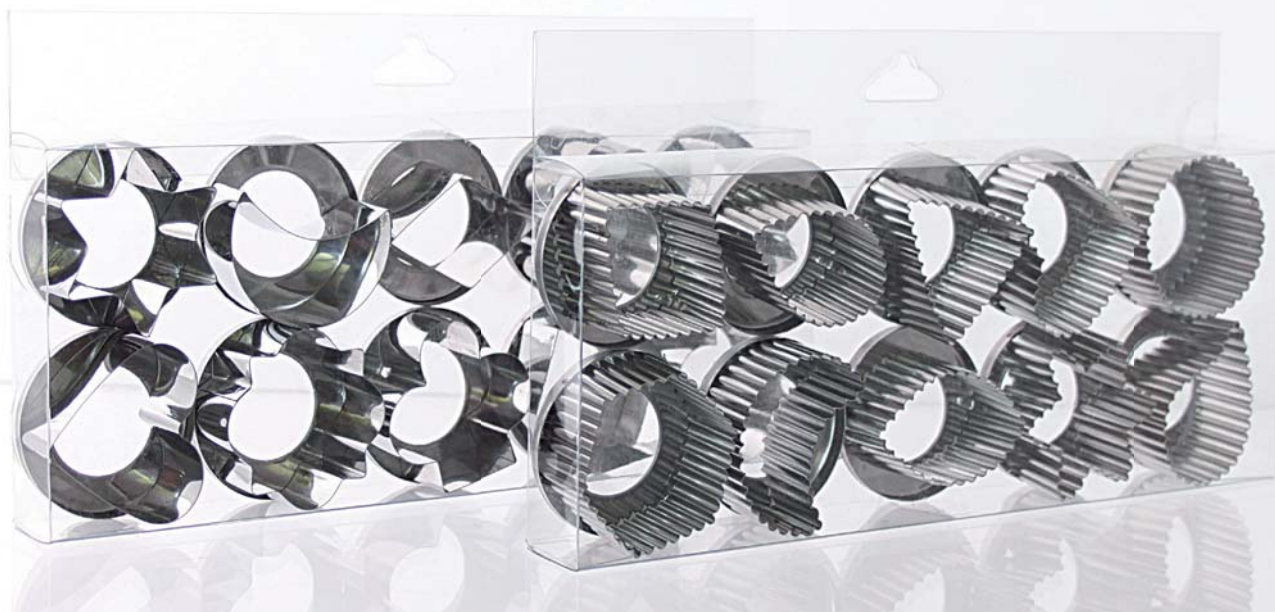

DE	AUSSTECHER
GB	CUTTERS
IT	TAGLIAPASTA
ES	CORTAPASTA

Material: Edelstahl

made of stainless steel

#		Ø mm / ↔ mm	↑ mm		
199770	“FISCH” / “FISH”	145 x 65	35	1 Set	
199886	“IGEL”, 3 Größen / “HEDGEHOG”, 3 pieces	67 / 75 / 90	30	1 Set	
199163	“SONNENBLUME” / “SUNFLOWER”	Ø: 100	25	1 Set	
199164	“SCHMETTERLING” / “BUTTERFLY”	Ø: 110	25	1 Set	
199165	“WEIHNACHTSAUSSTECHER”; glatt mit Böden in 10 versch. Formen (0,3 mm) / “CHRISTMAS-CUTTERS”; plain, with strong base, 10 different types (0,3 mm)	Ø: 50		1 Set	
199166	“WEIHNACHTSAUSSTECHER”; gewellt mit Böden in 10 versch. Formen (0,3 mm) / “CHRISTMAS-CUTTERS”; waved edges, with strong base, 10 different types (0,3 mm)	Ø: 50		1 Set	
199167	“WEIHNACHTSAUSSTECHER”; glatt, 8-teilig, bestehend aus: Glocke, Tannenbaum, Schmetterling, Stern, Weihnachtsstern, Ente, Herz und Pilz (0,3 mm) / “CHRISTMAS-CUTTERS”; plain, 8 different types, consisting of: bell, christmas tree, butterfly, star, shooting star, duck, heart and mushroom (0,3 mm)			1 Set	
199168	“NIKOLAUS”, Materialstärke 0,5 mm / “SANTA CLAUS”, thickness 0,5 mm	230 x 125	30	1 Set	
199760	“KOMET” / “COMET”	230 x 110	30	1	
199761	“KOMET”, Set: 3-teilig / “COMET”, Set: 3 pieces	87 x 35 127 x 50 167 x 75	20 20 20	1 Set	
199169	“STERN MIT LOCH”; Materialstärke 0,4 mm / “STAR WITH HOLE”; thickness 0,4 mm	Ø: 105	30	1	
199170	“STUTENKERL”; Materialstärke 0,5 mm, zweiteilig / “GINGERBREAD MAN”; thickness 0,5 mm, two parts	250 x 220	30	1	



Art.-Nr. 199770



Art.-Nr. 199886



Art.-Nr. 199163



Art.-Nr. 199164



Art.-Nr. 199165



Art.-Nr. 199166



Art.-Nr. 199167



Art.-Nr. 199168



Art.-Nr. 199760



Art.-Nr. 199761



Art.-Nr. 199169



Art.-Nr. 199170



DE	AUSSTECHEK
GB	CUTTERS
IT	TAGLIAPASTA
ES	CORTAPASTA

Material: Edelstahl

made of stainless steel

#		↔ mm	↑ mm	
199780	"SCHNEEMANN" / "SNOW MAN"	145 x 80	30	1
199790	"NIKOLAUSSTIEFEL" / "CHRISTMAS BOOT"	140 x 110	30	1
199800	"ENGEL" / "ANGEL"	140 x 100	30	1
199171	"TANNENBAUM" / "CHRISTMAS TREE" (0,4 mm)	150 x 125	30	1
199172	"TANNENBAUM" / "CHRISTMAS TREE" (0,4 mm)	200 x 153	30	1
199820	"GLOCKE" / "JINGLE BELL"	130 x 110	30	1
199860	"HASE" / "RABBIT"	180 x 80	30	1
199870	"HASE" / "RABBIT"	200 x 170	30	1
199850	"HASENKOPF" / "RABBIT-HEAD"	170 x 125	30	1
199830	"MARTINSGANS" / "GOOSE"	170 x 215	30	1
199840	"ENTE" / "DUCK"	200 x 170	30	1

Material: Weißblech

made of tin

#		↔ mm	
199570	ZAHLENAUSSTECHEK, Set mit 9 Zahlen. Zahlen von 0 – 9 / NUMBER CUTTERS, set consisting of 9 pieces, numbers from 0 to 9	110 x 60 x 30	1
199571	WEIHNACHTSAUSSTECHEK, Set mit 10 verschiedenen Ausstechern, im Karton / SET OF CHRISTMAS-CUTTERS, set consisting of 10 pieceese, in box		1



Art.-Nr. 199780



Art.-Nr. 199790



Art.-Nr. 199800



Art.-Nr. 199171 / 199172



Art.-Nr. 199820



Art.-Nr. 199860



Art.-Nr. 199870



Art.-Nr. 199850



Art.-Nr. 199830



Art.-Nr. 199840



Art.-Nr. 199570



Art.-Nr. 199571

Fachgeräte
Utensils
Attrezzatura
Utensilios

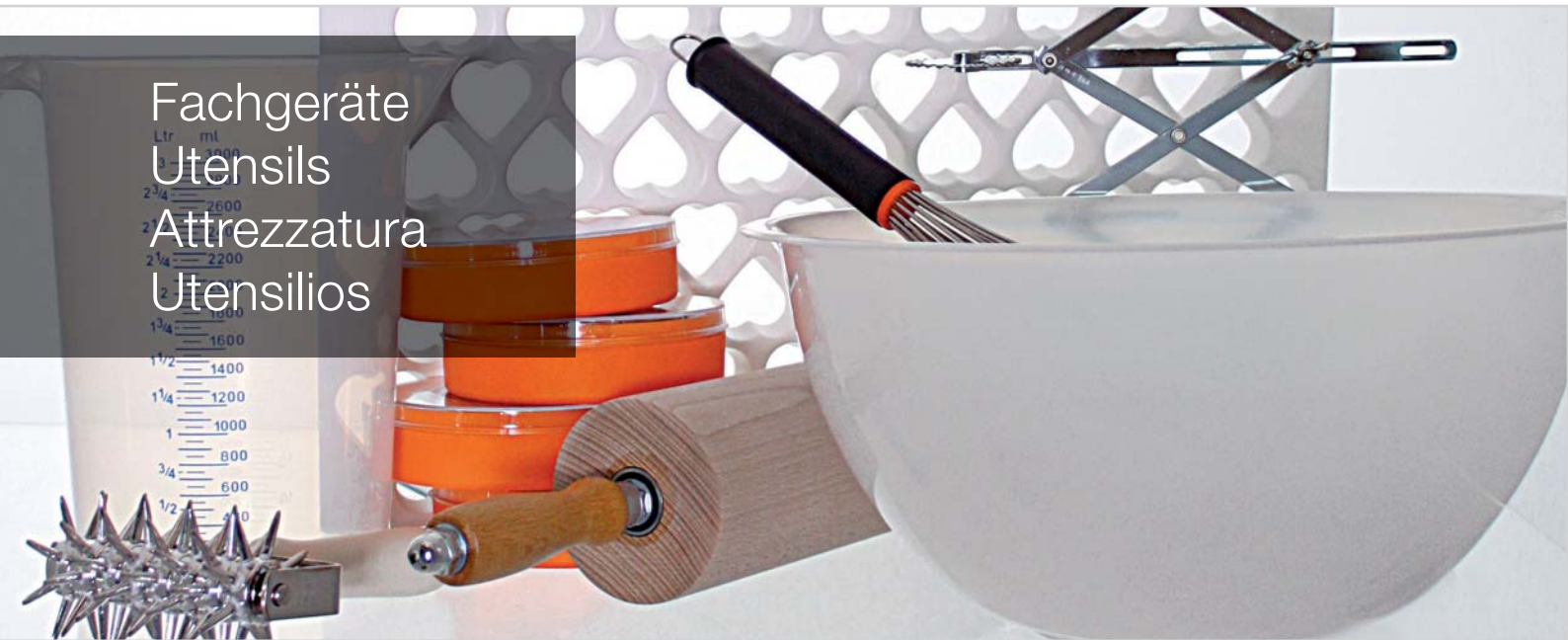

Art. 191091



DE	KAISERSEMELDRÜCKER
GB	"KAISERSEMEL"-MARKERS
IT	STAMPI PER PANE, ROSETTA
ES	MARCADOR DE PAN DE VIENNA

Holzgriff, Drücker Kunststoff wooden handle, marker made of white plastic

#	Ø mm		
191091	70	1	

Art. 191093



Material: Kunststoff, weiß made of plastic, white

#	Ø mm		
191093	70	1	

DE	BROT- UND BRÖTCHENDRÜCKER / TEIGDRÜCKER
GB	BREAD AND DOUGH MARKERS / DOUGH MARKERS
IT	STAMPI PER PANE, ROSETTA
ES	MARCADOR DE PAN DE VIENNA

Material: Edelstahl, stabiler Griff made of stainless steel, solid handle

#	Ø mm	↑ mm		
199585	80	57	5-eckig / 5 square	1
199586	160	57	5-eckig / 5 square	1

Art. 199585



Art. 199586



DE	BROT- UND BRÖTCHENDRÜCKER / TEIGDRÜCKER
GB	BREAD AND DOUGH MARKERS / DOUGH MARKERS
IT	STAMPI PER PANE, ROSETTA
ES	MARCADOR DE PAN DE VIENNA

Material: Edelstahl, stabiler Griff

made of stainless steel, solid handle



#		Ø mm	↑ mm	
199580	ohne Loch / without hole	80	57	1
199581	ohne Loch / without hole	65	57	1
199582	mit Loch / with hole	80	57	1
199583	mit Loch / with hole	65	57	1



Art. 199580

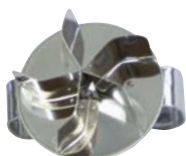

Art. 199581



Art. 199582



Art. 199583

Kunststoff, weiss

made of plastic, white

#		
166080	Kaisersmmele gerade / straight	1
166081	Kaisersmmele	1
166082	Kaisersmmele mit Loch / with hole	1
166083	Spirale / spiral	1



Art. 166080



Art. 166081



Art. 166082



Art. 166083

#		↔ mm	
166084	Wabe / comb	165 x 85	1
166085	Blume / flower	Ø 125	1
166086	Wabe / comb	140 x 110	1
166087	Quadrat / square	140 x 100	1
166088	Sonne / sun	Ø 125	1

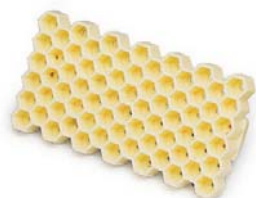

Art. 166084



Art. 166085



Art. 166086



Art. 166087



Art. 166088



DE	TORTENGITTERSTANZE
GB	LATTICE MATRIX
IT	STAMPO DECORA CROSTATE IN PS
ES	MOLDE PARA DECORACIÓN DE TARTAS A ROMBOS

Material: Polystyrol, weiß, bestehend aus 2 Teilen für Linzer Torten, Holländer Gebäck usw. made of white plastic (PS), 2 parts for "Linzer" cakes, Dutch pastries etc.

#	Ø	
158006	300	1

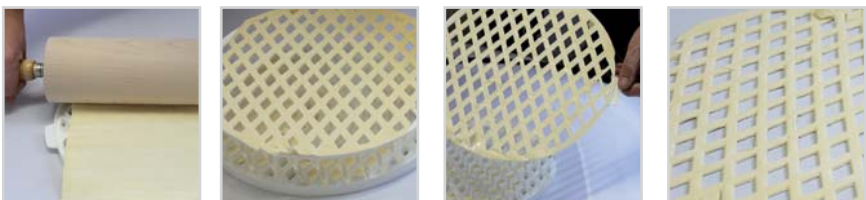

DE	SCHNITTENRAHMEN
GB	FRAME
IT	TELAJ
ES	MARCO



Material: Aluminium, doppelseitig verwendbar, – für 28 Schnitten 60 x 60 mm oder 33 Schnitten 80 x 40 mm – für 70 Schnitten 80 x 40 mm oder 54 Schnitten 65 x 65 mm made of aluminum, two-sided use, – for 28 pieces 60 x 60 mm or 33 pieces 80 x 40 mm – for 70 pieces 80 x 40 mm or 54 pieces 65 x 65 mm

#	↗ mm	→ mm	↑ mm	
199590	440	240	50	1
199591	560	370	50	1

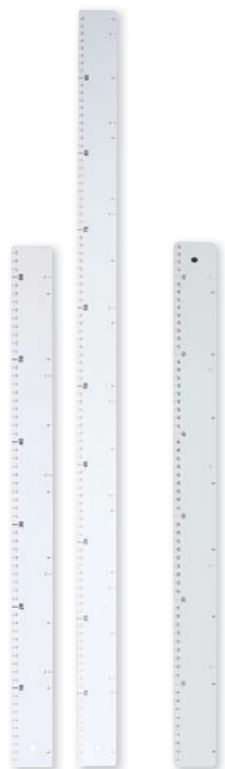

DE	BACKLINEALE
GB	DOUGH RULERS
IT	RIGA
ES	REGLA GRADUADA

Material: Polystyrol, flexibel, weiß mit Aufhängeöse 7 Einteilungen 8 cm, 5 Einteilungen 12 cm made of polystyrene, flexible, white with suspension hole; 7 divisions of 8 cm each and 5 divisions of 12 cm each

<input checked="" type="checkbox"/>	#	↗ mm	→ mm	↑ mm	
	200900	640	50	2	1

13 Einteilungen 8 cm, 8 Einteilungen 12 cm 13 divisions of 8 cm each and 8 divisions of 12 cm each

<input checked="" type="checkbox"/>	#	↗ mm	→ mm	↑ mm	
	200915	980	50	2	1

Material: Resopal, stabil, weiß mit Aufhängeöse 7 Einteilungen 8 cm, 5 Einteilungen 12 cm made of Formica, solid, white with suspension hole; 7 divisions of 8 cm each and 5 divisions of 12 cm each

<input checked="" type="checkbox"/>	#	↗ mm	→ mm	↑ mm	
	200899	645	50	2	1

DE	MEHLBESEN
GB	FLOUR BRUSHES
IT	SPAZZOLE PER FARINA
ES	CEPILLOS PARA HARINA

Holzrücken, Rosshaar

wooden grip, horse hair

#	↗ mm		
200238	300	hellbraun / beige	1
200239	300	schwarz / black	1



Kunststoffrücken, Rosshaar

grip made of plastic, bristles horse hair

#	↗ mm		
200260	300	hellbraun / beige	1
200261	300	schwarz / black	1



stabiler Kunststoffkörper mit glatter Oberfläche, hochwertige Polyester-Borsten, hitzebeständig bis 134°C, mit Aufhängeloch

stable plastic body with smooth surface, high-quality polyester bristles, heat resistant up to 134°C, with hanging hole



#	↗ mm		
120800	300	○	1
120801	300	●	1
120802	300	●	1



9

DE	BROTSTREICHER
GB	BREAD BRUSHES
IT	SPAZZOLE PER PANE
ES	CEPILLOS PARA PAN

Holzstiel, 50% Schweineborste, 50% Kunstborste (Polyester-Faser), mit Aufhängeloch

wooden handle, 50% pig bristles, 50% synthetic bristle, with hanging hole



#	↗ mm		
200234	245	4-reihig / 4 rows	1
200235	320	5-reihig / 5 rows	1
200236	410	6-reihig / 6 rows	1
200237	460	7-reihig / 7 rows	1



stabiler Kunststoffkörper mit glatter Oberfläche, hochwertige Polyester-Borsten, hitzebeständig bis 134°C, mit Aufhängeloch

stable plastic body with smooth surface, high-quality polyester bristles, heat resistant up to 134°C, with hanging hole



#	↗ mm		
120810	400	○	1
120811	400	●	1
120812	400	●	1



DE	PINSEL
GB	BRUSHES
IT	PENNELLI
ES	PINCELES

Holzstiel mit Aufhängeöse, weißgebleichte naphthalinfreie Borsten, lebensmittelecht

wooden handle with hole, white bleached bristles, food safe



#	→ mm	
<input checked="" type="checkbox"/> 200200	10	1
<input checked="" type="checkbox"/> 200201	15	1
<input checked="" type="checkbox"/> 200202	20	1
<input checked="" type="checkbox"/> 200203	25	1
<input checked="" type="checkbox"/> 200204	30	1
<input checked="" type="checkbox"/> 200205	35	1
<input checked="" type="checkbox"/> 200206	40	1
<input checked="" type="checkbox"/> 200207	50	1
<input checked="" type="checkbox"/> 200208	60	1
<input checked="" type="checkbox"/> 200209	80	1
<input checked="" type="checkbox"/> 200210	100	1

#	→ mm Zoll / inch	
<input checked="" type="checkbox"/> 200212	1/2"	1
<input checked="" type="checkbox"/> 200213	3/4"	1
<input checked="" type="checkbox"/> 200214	1"	1
<input checked="" type="checkbox"/> 200215	1 1/2"	1
<input checked="" type="checkbox"/> 200216	2"	1
<input checked="" type="checkbox"/> 200217	2 1/2"	1
<input checked="" type="checkbox"/> 200218	3"	1
<input checked="" type="checkbox"/> 200219	4"	1

Kunststoffstiel mit Aufhängeöse, naphthalinfreie Borsten, lebensmittelecht.

Handle made of plastic, with hole, food safe. White bleached bristles.



#	→ mm	
<input checked="" type="checkbox"/> 200271	25	1
<input checked="" type="checkbox"/> 200272	30	1
<input checked="" type="checkbox"/> 200273	35	1
<input checked="" type="checkbox"/> 200274	40	1
<input checked="" type="checkbox"/> 200275	50	1
<input checked="" type="checkbox"/> 200276	60	1
<input checked="" type="checkbox"/> 200280	75	1

DE	PINSEL "SILIKON"
GB	BRUSHES "SILICONE"
IT	PENNELLI IN SILICONE
ES	PINCELES EN SILICONA

Material: Silikon, mit Metallstiel, 5-reihig, bis + 300 °C

made of silicone, with metal handle, 5 rows, up to + 300 °C



#	→ mm	↗ mm	
<input checked="" type="checkbox"/> 200313	35	230	1
<input checked="" type="checkbox"/> 200312	42	235	1
<input checked="" type="checkbox"/> 200299	50	280	1

DE	PINSEL
GB	BRUSHES
IT	PENNELLI
ES	PINCELES

Stiel PE, **weißgebleichte, naphthalinfreie Borsten** stick made of polyethylene, bleached bristles

#	→ mm	
<input checked="" type="checkbox"/> 200290	40	1
<input checked="" type="checkbox"/> 200291	50	1
<input checked="" type="checkbox"/> 200292	60	1
<input checked="" type="checkbox"/> 200293	75	1



Borsten in zwei Qualitäten

Stiel PE, **superweiche Polyester-Borsten weiß** stick made of polyethylene, super soft polyester bristles

#	→ mm	
<input checked="" type="checkbox"/> 202294	40	1
<input checked="" type="checkbox"/> 202295	50	1
<input checked="" type="checkbox"/> 202296	60	1
<input checked="" type="checkbox"/> 202297	75	1

- schwarzer Kunststoffgriff mit Aufhängeöse
- rote Nylonborsten
- bis 150 °C hitzebeständig
- Plastic handle with hole
- red bristles made of nylon
- Heat resistant up to +150 °C

#	→ mm	
<input checked="" type="checkbox"/> 200285	25	1
<input checked="" type="checkbox"/> 200286	35	1
<input checked="" type="checkbox"/> 200287	50	1
<input checked="" type="checkbox"/> 200288	60	1



NEW



NEW

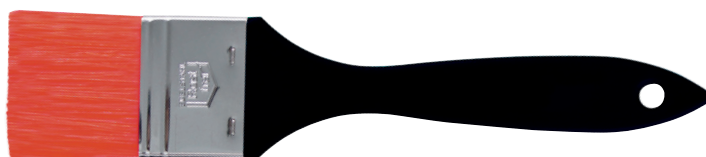



DE	STIPPROLLER
GB	ROLLER DOCKERS
IT	RULLI BUCASFOGLIA
ES	RODILLOS PARA PINCHAR HOJALDRE

Material: Edelstahl / Aluminium mit ergonomischem Kunststoffgriff
 made of stainless steel and aluminum with ergonomic plastic handle

#	→ mm		
154104	120 mm	1	



Material: Kunststoff (POM), elfenbein mit verstärktem Kunststoffgriff
 made of plastic (POM), ivory with reinforced plastic handle

#	→ mm		
<input checked="" type="checkbox"/> 200001	65	1	
<input checked="" type="checkbox"/> 200002	120	1	



Material: Kunststoff (POM), elfenbein ergonomischer Griff, Halterung aus Metall
 made of plastic (POM), ergonomic plastic handle, mounting made of steel

#	→ mm		
200182	270	1	



DE	STRUDELWALZEN
GB	CUTTING ROLLERS
IT	RULLI TAGLIAPASTA (PER STRUDEL)
ES	RODILLOS PARA CORTAR LA MASA

Material: Edelstahl, mit ergonomischem Kunststoffgriff
 made of stainless steel with ergonomic plastic handle

#	→ mm		
154300	65	1	



Material: Kunststoff (POM), elfenbein mit verstärktem Kunststoffgriff für Mürb- oder Hefeteig
 made of plastic (POM), ivory with reinforced plastic handle for short crust pastry and yeast dough

#	→ mm		
<input checked="" type="checkbox"/> 200003	65	1	

DE	GITTERSCHNEIDER
GB	LATTICE CUTTING ROLLERS
IT	RULLI PER LOSANGHE
ES	RODILLOS A ROMBAS

Material: Edelstahl
mit ergonomischem Kunststoffgriff
Schneideabstand ca. 7 mm

made of stainless steel
with ergonomic plastic handle
distance between blades 7 mm



#	→ mm	
154203	120	1

Material: Kunststoff (POM), elfenbein
mit verstärktem Kunststoffgriff

made of plastic (POM), ivory
with reinforced plastic handle

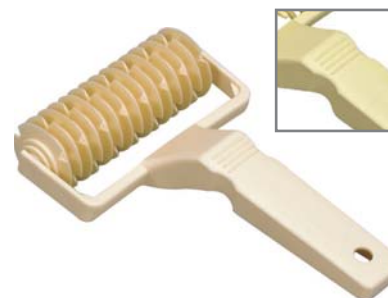

#	→ mm	
200004	65	1
200114	120	1

-
-

DE	DREIECK-AUSSTECHEWALZEN
GB	TRIANGULAR CROISSANT CUTTERS
IT	RULLI TAGLIA CROISSANTS
ES	RODILLOS PARA CORTAR CROISSANTS

für Croissants

for croissants

Material: Edelstahl, ergonomischer Kunststoffgriff

made of stainless steel, ergonomic plastic handle



9

#		mm	
154420	einfach / single	a=110, h=150	1
154421	einfach / single	a=180, h=140	1
154422	einfach / single	a=180, h=200	1
154424	einfach / single	a= 70, h=100	1
154499	einfach / single	a= 97, h=210	1
154427	doppelt / double	a=180, h=200	1
154430	dreifach / triple	a=180, h=200	1
154429	dreifach / triple	a=180, h=140	1

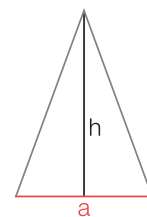

Art. 154424



DE	TEIGSCHNEIDER
GB	EXPANDABLE DOUGH CUTTERS
IT	TAGLIAPASTA ESTENSIBILE (BICICLETTA), INOX
ES	CORTADOR EXTENSIBLE - BICICLETA

Messer: Edelstahl, rostfrei, sehr stabile Ausführung, Schnittbreite max. 125 mm
 Rädchen-Durchmesser 55 mm

knives made of stainless steel, very strong quality,width between wheels max. 125 mm
 wheel diameter 55 mm



#			
153100	5 Rädchen glatt / 5 wheels plain	1	
153110	5 Rädchen gezackt / 5 wheels serrated	1	
153200	7 Rädchen glatt / 7 wheels plain	1	
153210	7 Rädchen gezackt / 7 wheels serrated	1	
153204	Flügelschraube mit Mutter / screw with nut	1	



#			
153300	5 Rädchen glatt und gezackt / 5 wheels plain and serrated	1	
153400	7 Rädchen glatt und gezackt / 7 wheels plain and serrated	1	
153204	Flügelschraube mit Mutter / screw with nut	1	

DE	TEIGSCHNEIDER
GB	DOUGH CUTTER
IT	TAGLIAPASTA ESTENSIBILE CON BASE FISSA
ES	CORTADOR EXTENSIBLE DE BARRA FIJA

Material: Edelstahl, rostfrei
 bestehend aus 8 Messer (gefedert) und Stange 70 cm inklusive Skala 60 cm,
 Messerdurchmesser 5,5 cm

made of stainless steel, 8 knives (spring loaded) and rod 70 cm, engraved scale 60 cm,
 diameter of knives 5,5 cm



#		kg		
153450	Komplett = 8 Rädchen glatt und Stange / complete set = 8 wheels plain and rod	1,2	1	
153451	Ersatzstange / extra rod		1	
153452	Ersatzmesser / extra knife		1	

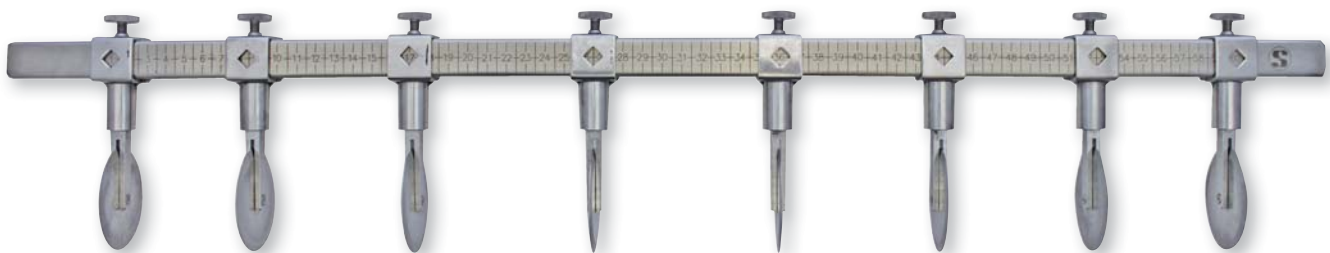

DE	TEIG- UND PIZZASCHNEIDER
GB	DOUGH AND PIZZA CUTTERS
IT	ROTELLE TAGLIA PASTA E PIZZA
ES	RUEDECILLA (PARA MASA Y PIZZA)

Material: Edelstahl, mit Kunststoffgriff mit Handschutz und Aufhängeöse
sehr robuste Ausführung

made of stainless steel, plastic handle and hook, with hand protection
very strong quality

#		Ø mm		
<input checked="" type="checkbox"/>	200005	einfach, glatt / single, plain	55	1
<input checked="" type="checkbox"/>	200006	einfach gewellt / single serrated	55	1
<input checked="" type="checkbox"/>	200007	doppelt glatt und gewellt / double, plain and serrated	55	1
<input checked="" type="checkbox"/>	200115	einfach, glatt / single, plain	120	1



Art. 200115



Art. 200005



Art. 200006



Art. 200007

Material: Edelstahl, mit ergonomischem Griff aus schwarzem PP; ca. 200 mm lang

made of stainless steel, ergonomic handle made of black PP; ca. 200 mm length

#		Ø mm	
200510	einfach, glatt / single, plain	40	1
200511	einfach, glatt / single, plain	55	1
200512	einfach, glatt / single, plain	65	1
200515	einfach gewellt / single serrated	40	1
200516	einfach gewellt / single serrated	55	1
200517	einfach gewellt / single serrated	65	1



Material: Edelstahl, mit ergonomischem Griff aus schwarzem PP; ca. 255 mm lang

made of stainless steel, ergonomic handle made of black PP; ca. 255 mm length

#		Ø mm	
200116	einfach, glatt / single, plain	125	1



DE	ROLLHÖLZER
GB	ROLLING PINS
IT	RULLI IN LEGNO
ES	RODILLOS AMASADORES EN MADERA

Material: Buchenholz, mit Präzisionskugellager, Walzen-Durchmesser: 90 mm
 made of beech wood, with precision ball-bearing, roller diameter: 90 mm



#	→ mm (Walze / roller)	
200160	250	1
200161	300	1
200162	350	1
200163	400	1
200164	450	1

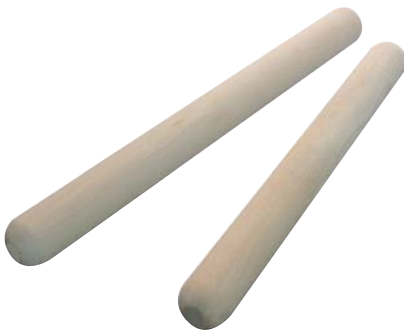

#	↗ mm	Ø mm	
203300	420	45	1
203310	500	45	1



DE	KARIERHOLZ
GB	DECORATING PIN CHECKERED
IT	RULLO DA DECORAZIONE, A QUADRETTI
ES	RODILLO DECORADORES, A CUADROS

Material: Buchenholz, mit Präzisionskugellager, mit Holzgriffen, Walzen-Durchmesser: 45 mm
 made of beech wood, with precision ball-bearing, wooden handles, roller diameter: 45 mm



#	→ mm (Walze / roller)	
200166	200	1



DE	RIEFENHOLZ
GB	DECORATING PIN GROOVED
IT	RULLO DA DECORAZIONE, A SCANALATURE
ES	RODILLO DECORADORES, ESTRIADOS

Material: Buchenholz, mit Präzisionskugellager, mit Holzgriffen, Walzen-Durchmesser: 45 mm
 made of beech wood, with precision ball-bearing, wooden handles, roller diameter: 45 mm



#	→ mm (Walze / roller)	
200165	200	1

DE	ROLLWALZEN
GB	ROLLING PINS
IT	RULLI IN POLIETILENE
ES	RODILLOS AMASADORES, PLASTICO

Vollkunststoff (PE), weiss, hygienisch,
einfach zu reinigen, mit Edelstahlwelle,
Walzendurchmesser: 80mm

made of solid polyethylene, hygienic,
easy to clean, shaft stainless steel,
roller diameter: 80 mm



#	→ mm (Walze / roller)	
200126	300	1
200127	400	1
200128	450	1
200129	500	1

Material: Kunststoff (PE), weiss

made of PE, white



#	↗ mm	Ø mm	
200096	300	48	1
200097	400	48	1
200123	500	48	1

mit Griff

with handles

#	↗ mm	Ø mm	
200124	500	48	1
200125	600	58	1





 Logo möglich / Private branding possible

DE	TEIGSCHABER FLEXIBEL	SOFT
GB	DOUGH SCRAPERS FLEXIBLE	
IT	RASCHIETTI FLESSIBILI	
ES	RASQUETAS FLEXIBLES	

Material: LDPE, weiß
 hitzebeständig bis ca.+100°C,
 Materialstärke 2,5 mm

made of LDPE, white
 heat resistant up to approx. +100°C,
 thickness 2,5 mm

#	↔ mm		
227240	145 x 97	100	
227241	137 x 86	100	
227242	160 x 120	100	
227243	120 x 86	100	
227244	120 x 88	100	



DE	TEIGABSTECHER MIT GRIFFLEISTE
GB	SCRAPERS WITH REINFORCED GRIP
IT	RASCHIETTI CON MANIGLIA RINFORZATA
ES	RASQUETAS CON EMPUÑADURA REFORZADA

#	↔ mm		
227350	221 x 130 mm	eckig / with edges	100
227351	209 x 130 mm	rund / round edges	100
227364	125 x 100 mm	eckig / with edges	100
227230	120 x 100 mm	eckig / with edges	100



DE	TEIGSCHABER
GB	DOUGH SCRAPERS
IT	RASCHIETTI
ES	RASQUETAS

#	↔ mm		
227352	128 x 90	asyetrisch / asyetrical	100
227355	120 x 80	Cremeschaber / cream scraper	100
227356	151 x 102	Cremeschaber / cream scraper	100
227360	112 x 78	Kamm / comb	100
227365	116 x 78	rund / round	100
227231	137 x 86	Cremeschaber / cream scraper	100
227232	120 x 88	Cremeschaber / cream scraper	100
227235	105 x 105 x 105	Kamm / comb	100



DE	KESSELSCHABER
GB	BOWL SCRAPERS
IT	RASCHIETTI PER BASTARDELLE
ES	RASQUETAS PARA CALDEROS

#	↔ mm	
227363	204 x 151	100
227233	160 x 120	100



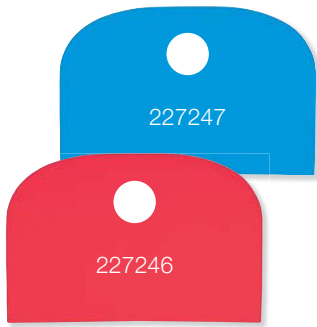

DE	TEIGSCHABER "SCHLESINGER" – FLEXIBEL	SOFT
GB	DOUGH SCRAPERS "SCHLESINGER" – FLEXIBLE	
IT	RASCHIETTI FLESSIBILI	
ES	RASQUETAS FLEXIBLES	

Material: LDPE
hitzebeständig bis ca.+100°C,
Materialstärke 2,5 mm

made of LDPE
heat resistant up to approx. +100°C,
thickness 2,5 mm

#	↔ mm			
227246	148 x 99	● rot / red	100	
227247	148 x 99	● blau / blue	100	

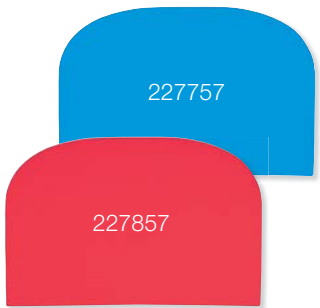

DE	TEIGSCHABER FLEXIBEL	SOFT
GB	DOUGH SCRAPERS FLEXIBLE	
IT	RASCHIETTI FLESSIBILI	
ES	RASQUETAS FLEXIBLES	

Material: LDPE
hitzebeständig bis ca.+100°C,
Materialstärke 2,5 mm

made of LDPE
heat resistant up to approx. +100°C,
thickness 2,5 mm

#	↔ mm			
227857	148 x 99	● rund / round	100	
227757	148 x 99	● rund / round	100	

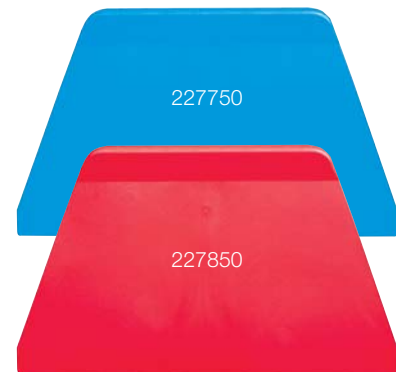

DE	TEIGSCHABER
GB	DOUGH SCRAPERS
IT	RASCHIETTI
ES	RASQUETAS

#	↔ mm			
227850	221 x 130	● Teigabstecher / with edges	100	
227863	204 x 151	● Kessel / Bowl scraper	100	
227852	128 x 90	● asyetrisk / asyetriskal	100	
227856	151 x 102	● Cremeschaber / cream scraper	100	
227750	221 x 130	● Teigabstecher / with edges	100	
227763	204 x 151	● Kessel / Bowl scraper	100	
227752	128 x 90	● asyetrisk / asyetriskal	100	
227756	151 x 102	● Cremeschaber / cream scraper	100	

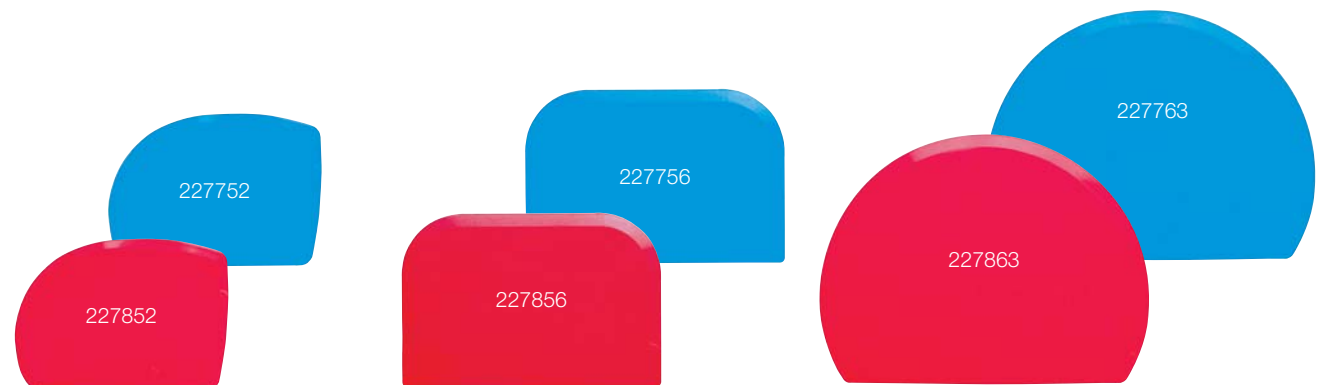

DE	ABSTECHER
GB	SCRAPERS
IT	RASCHIE, INOX
ES	CORTANTE

Material: Edelstahl, Kunststoffgriff, Ecken abgerundet

made of stainless steel, black plastic handle, round edges

#	↔ mm		
200600	110 x 120	● flexible Klinge / flexible blade	1
199070	110 x 120	○ flexible Klinge / flexible blade	1
199075	110 x 120	● flexible Klinge / flexible blade	1
200601	110 x 120	● steife Klinge / stiff blade	1
200602	130 x 135	● steife Klinge / stiff blade	1



Art. 200600



Art. 199075



Art. 199070

9

Material: Edelstahl, Kunststoffgriff blau

made of stainless steel, blue plastic handle

#	↔ mm		
200702	195 x 145	Trapez / trapeze	1
200703	160 x 170	Rechteck / rectangle	1

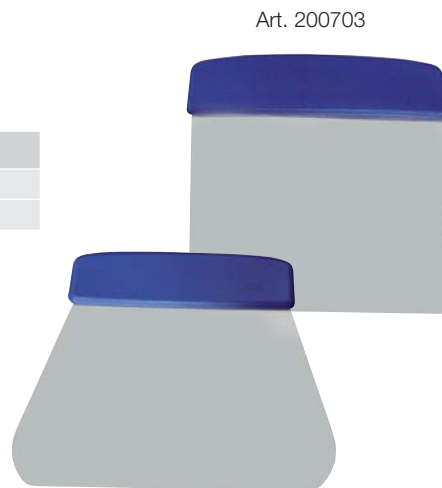

Art. 200702

DE	SCHABER EDELSTAHL
GB	SCRAPERS STAINLESS STEEL
IT	RASCHIETTI, INOX
ES	RASQUETAS, INOX

Material: Edelstahl

made of stainless steel

#	↔ mm		
154840	100 x 100	Quadrat / square	10
154841	110 x 110	Dreieck / triangular	10
154842	110 x 75	Rechteck / rectangular	10

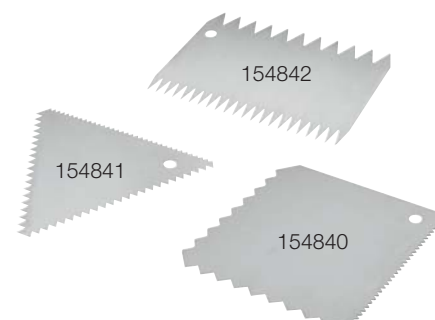



DE	SPACHTELN
GB	SPATULAS
IT	RASCHIE, INOX
ES	ESPÁTULAS TRIANGULARES, MANGO NEGRO

Material: Edelstahl, Kunststoffgriff schwarz (PP) made of stainless steel, black plastic handle (PP)

	#	→ mm	
<input checked="" type="checkbox"/>	200500	40	1
<input checked="" type="checkbox"/>	200501	60	1
<input checked="" type="checkbox"/>	200502	80	1
<input checked="" type="checkbox"/>	200503	100	1
<input checked="" type="checkbox"/>	200504	120	1



DE	SPACHTELN
GB	SPATULAS
IT	RASCHIE, INOX
ES	RASQUETAS

Material: Edelstahl, Griff Kunststoff (PS) made of stainless steel, plastic handle (PS)

	#	↔ mm	
<input checked="" type="checkbox"/>	200700	170	1
<input checked="" type="checkbox"/>	200701	270	1



DE	ABSTECHER
GB	SCRAPERS
IT	RASCHIE, INOX
ES	CORTANTE

Material: Edelstahl, runder Griff made of stainless steel, with round handle

	#	↔ mm	
	200620	125 x 105	1
	200621	150 x 105	1
	200622	175 x 105	1

Material: Edelstahl, Materialstärke: 0,8 mm made of stainless steel, thickness: 0,8 mm

	#	↔ mm	Form	
	200610	120 x 115	flach / flat	1
	200611	120 x 110	abgerundet / oblique	1



DE	SPACHTEL – EXTRA STABIL
GB	SPATULA – EXTRA STRONG
IT	RASCHIA - EXTRA STABILE
ES	ESPATULA PAR CHOCOLATE – MUY FUERTE

Material: Edelstahl, Griff Kunststoff, genietet, speziell für Schokolade made of stainless steel, plastic handle, with rivets, especially for chocolate

	#	→ mm	
	200710	180	1

DE	STIELSCHABER
GB	SPATULAS
IT	SPATOLE
ES	ESPÁTULAS

Material: Silikon, mit Metallstiel
bis + 300 °C

made of silicone, with metal handle
heat resistant up to + 300 °C

	#	↔ mm	↗ mm	
<input checked="" type="checkbox"/>	200925	● 28 x 60	210	1
<input checked="" type="checkbox"/>	200926	● 55 x 85	285	1
<input checked="" type="checkbox"/>	200927	● 70 x 115	325	1
<input checked="" type="checkbox"/>	200928	○ 55 x 85	285	1
<input checked="" type="checkbox"/>	200929	○ 70 x 115	325	1

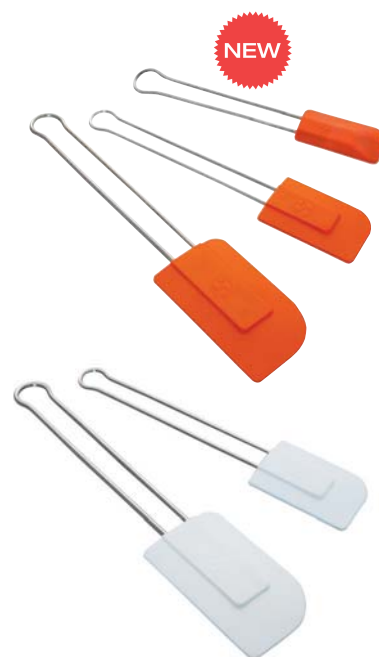

Material: Silikon, Griff aus hitzebeständigem
Kunststoff bis + 260 °C, mit Aufhängeöse

made of silicone, handle made of heat-
resistant plastic, up to + 260 °C, with hook

	#	↔ mm	↗ mm	
<input checked="" type="checkbox"/>	200750	85 x 53	250	1
<input checked="" type="checkbox"/>	200751	115 x 68	350	1
<input checked="" type="checkbox"/>	200752	115 x 68	450	1



9

DE	STIELSCHABER – LÖFFEL
GB	SPATULAS – SPOON
IT	SPATOLE
ES	ESPÁTULAS

Material: Silikon, Griff aus hitzebeständigem
Kunststoff bis + 260 °C, mit Aufhängeöse

made of silicone, handle made of heat-
resistant plastic, up to + 260 °C, with hook

	#	↔ mm	↗ mm	
<input checked="" type="checkbox"/>	200760	116 x 68	250	1
<input checked="" type="checkbox"/>	200761	116 x 68	350	1
<input checked="" type="checkbox"/>	200762	116 x 68	450	1



DE	RÜHRSPATEL
GB	SPATULAS
IT	SPATOLE
ES	ESPÁTULAS PARA DILUIR

Material: Polyamid/Nylon, glasfaserverstärkt,
hitzebeständig bis 220 °C, hygienisch

made of polyamide/nylon, reinforced fibreglass,
heat resistant up to 220 °C, hygienic

	#	↗ mm		
<input checked="" type="checkbox"/>	200930	250	6	
<input checked="" type="checkbox"/>	200931	300	6	
<input checked="" type="checkbox"/>	200932	350	6	
<input checked="" type="checkbox"/>	200933	400	6	
<input checked="" type="checkbox"/>	200934	450	6	
<input checked="" type="checkbox"/>	200935	500	6	



DE	RÜHRKEULEN
GB	SPOONS
IT	CUCCHIAONI IN LEGNO
ES	CUCHARA

Material: Buchenholz

made of beech wood

	#	↗ mm		
	203423	300	1	
	203424	350	1	
	203425	400	1	
	203426	450	1	
	203427	500	1	
	203428	600	1	



9

DE	KONDITORLÖFFEL
GB	SPOONS
IT	CUCCHIAONI IN LEGNO
ES	CUCHARA

Material: Buchenholz

made of beech wood

	#	↗ mm		
	203429	300	1	
	203430	350	1	
	203431	400	1	
	203432	450	1	
	203433	500	1	
	203434	600	1	



DE	MASSENRÜHRSPATEL
GB	SPATULAS
IT	SPATOLE IN LEGNO
ES	ESPÁTULAS PARA DILUIR

Material: Buchenholz

made of beech wood



	#	↗ mm		
	203435	350	1	
	203436	400	1	
	203437	500	1	



DE	BROTFORMEN / GÄRKÖRBE
GB	BREAD PROOFING BASKETS
IT	CESTINI DA LIEVITAZIONE PER PANE
ES	MOLDES PARA PAN, MIMBRE

Material: Peddigrohr

made of rattan

#		 g	↑ mm	↑ mm	
	▼ geflochtener Boden / plaited bottom				
201200	Rund / round	500	75	Ø 190	6
201210	Rund / round	1000	85	Ø 220	6
201220	Rund / round	1500	95	Ø 250	6
201230	Rund / round	2000	88	Ø 290	6
201300	Oval	500	80	240 x 140	6
201302	Oval	750	85	200 x 120	6
201310	Oval	1000	95	260 x 160	6
201320	Oval	1500	90	320 x 180	6
201330	Oval	2000	103	360 x 200	6
201400	Lang, runder Kopf / long, round shape	500	90	240 x 130	6
201410	Lang, runder Kopf / long, round shape	1000	90	340 x 130	6
201420	Lang, runder Kopf / long, round shape	1500	90	430 x 130	6
201430	Lang, runder Kopf / long, round shape	2000	95	460 x 150	6
201440	Lang, runder Kopf / long, round shape	3000	95	500 x 170	6
201450	Lang, runder Kopf / long, round shape	300	55	410 x 95	6
201451	Lang, runder Kopf / long, round shape	500	55	460 x 100	6
201500	Lang, eckiger Kopf / long, angled shape	1000	85	320 x 130	6
201510	Lang, eckiger Kopf / long, angled shape	1250	83	360 x 130	6
201520	Lang, eckiger Kopf / long, angled shape	1500	85	380 x 140	6
201850	Dreieck / triangle	500	80	180 x 180 x 180	6
201851	Dreieck / triangle	1000	80	230 x 230 x 230	6
201852	Quadrat / square	1000	80	220 x 220	6
	▼ Holzboden / wooden bottom				
201600	Lang, runder Kopf / long, round shape	500	80	240 x 120	6
201610	Lang, runder Kopf / long, round shape	1000	75	340 x 130	6
201620	Lang, runder Kopf / long, round shape	1500	90	430 x 130	6
201630	Lang, runder Kopf / long, round shape	2000	90	460 x 150	6
201700	Lang, eckiger Kopf / long, angled shape	1000	85	320 x 130	6
201710	Lang, eckiger Kopf / long, angled shape	1250		360 x 130	6
201720	Lang, eckiger Kopf / long, angled shape	1500	90	380 x 140	6
201730	Lang, eckiger Kopf / long, angled shape	2000	88	440 x 140	6
	▼ Holzboden speziell für Schnittenbrot / wooden bottom				
201800	Lang, eckiger Kopf / long, angled shape	3000	95	500 x 160	6
201810	Lang, eckiger Kopf / long, angled shape	4000	100	550 x 160	6
201820	Lang, eckiger Kopf / long, angled shape	5000	100	600 x 160	6
201830	Lang, eckiger Kopf / long, angled shape	6000	100	650 x 160	6



Art.-Nr. 201200 bis 201230



Art.-Nr. 201300 bis 201330



Art.-Nr. 201400 bis 201440



Art.-Nr. 201500 bis 201520



Art.-Nr. 201600 bis 201630



Art.-Nr. 201700 bis 201730



Art.-Nr. 201800 bis 201830



Art.-Nr. 201450 und 201451



Art.-Nr. 201852



Art.-Nr. 201850, 201851

DE	GÄRTÜCHER
GB	COTTON LINERS
IT	TELA PER I CESTINE DA LIEVITAZIONE
ES	PAÑO PARA MOLDES PARA PAN

Material: 95 % Baumwolle, 5 % Elastomer weiß in 3 Größen. Mit normalem Waschmittel ohne Weichspüler und Bleichmittel bis 40°C waschbar.

Material: cotton 95%, elastomer 5% white in 3 sizes. Can be washed up to 40°C with normal detergent without the softener and bleaching.



#		↔ mm	
201901	für runde Gärkörbe / for round bread proofing baskets	19	1
201902	für runde Gärkörbe / for round bread proofing baskets	22	1
201903	für runde Gärkörbe / for round bread proofing baskets	25	1
201904	für rechteckige Gärkörbe / for rectangular bread proofing baskets	12 x 27	1
201905	für rechteckige Gärkörbe / for rectangular bread proofing baskets	13 x 35	1
201906	für rechteckige Gärkörbe / for rectangular bread proofing baskets	14 x 42	1



DE	HANDBÜRSTE SPEZIELL ZUM REINIGEN VON GÄRKÖRBE
GB	CLEANING BRUSH FOR BREAD PROOFING BASKETS
IT	SPAZZOLA PER LA PULIZIA DE CESTINI PER LIEVITAZIONE
ES	CEPILLOS PARA LIMPIEZA

Griff aus Holz; Borsten Polyester

wooden grip, bristles polyester

#	↔ mm	
201907	135 x 40 x 70	1

DE	BROTFORMEN	NICHT zum Backen geeignet! NOT for baking!
GB	BREAD PROOFING	
IT	CESTINI DA PANE IN POLIPROPILENE	
ES	MOLDES PARA PAN	

Material: PP, hygienisch, lebensmittelecht, spülmaschinenfest, reinigungsfreundlich durch undurchlässige Oberfläche, stapelbar

made of PP, hygienic, food safe, dishwasher-proof, easy cleaning due to impermeable surface, durable, stackable

#		g	mm	
201000	● rund / round	500	Ø 190	6
201010	● rund / round	1000	Ø 220	6
201020	● rund / round	1500	Ø 250	6
201030	● rechteckig / rectangular	500	120 x 270	6
201040	● rechteckig / rectangular	1000	130 x 350	6
201050	● rechteckig / rectangular	1500	140 x 420	6



DE	BROTFORMEN „ANTIBAC“	NICHT zum Backen geeignet! NOT for baking!
GB	BREAD PROOFING „ANTIBAC“	
IT	CESTINI DA PANE IN POLIPROPILENE „ANTIBAC“	
ES	MOLDES PARA PAN „ANTIBAC“	



Material: **PP mit Naturfasermaterial**, lebensmittelecht, spülmaschinenfest, reinigungsfreundlich durch undurchlässige Oberfläche

Made of PP with natural fibre material, food safe, dishwasher safe, easy to clean due to impermeable surface

Antibakterielle Wirkung durch Naturfasern

Antibacterial effect through natural fibres.

Innerhalb kurzer Zeit werden Bakterien, Keime und andere Erreger auf der Oberfläche effektiv abgetötet. Die antibakterielle Wirkung wird durch einen natürlichen Wirkstoff erzielt. Keine Metallionen, Metallsalze, Nanopartikel oder synthetischen Wirkstoffe enthalten. Umweltschonende Produktion durch nachwachsende Ressourcen.

Within a short time, bacteria, germs and other pathogens on the surface are effectively killed off. The antibacterial effect is achieved by a natural active ingredient. Do not contain metal ions, metal salts, nanoparticles or synthetic agents. Environmentally friendly production through renewable resources.

Getestet nach ISO 22196:2011

Tested according to ISO 22196:2011

#		g	mm	
201005	● rund / round	500	Ø 190	6
201015	● rund / round	1000	Ø 220	6
201025	● rund / round	1500	Ø 250	6
201035	● rechteckig / rectangular	500	120 x 270	6
201045	● rechteckig / rectangular	1000	130 x 350	6
201055	● rechteckig / rectangular	1500	140 x 420	6





DE	SCHNEEBESEN
GB	WHISKS
IT	FRUSTE
ES	BATIDORES

Material: Edelstahl; schwarzer thermo-
plastischer, Griff mit Aufhängeöse,
hitzebeständig bis 200°C, wasserdicht;
spülmaschinenfest; schwere Qualität,
Drahtstärke 1,6 mm; 24 Drähte

made of stainless steel; black coloured thermo-
plastic handle, hook, heat resistant
up to 200°C, water proof,
dishwasher proof; heavy quality,
wire thickness 1,6 mm; 24 wires



	#	↗ mm	🛒
☑	170080	250	12
☑	170081	300	12
☑	170082	350	12
☑	170083	400	12
☑	170084	450	12
☑	170085	500	12



Material: Edelstahl; handlicher Griff, für leichte
Massen; **Drahtstärke 1,6 mm, 24 Drähte**

made of stainless steel; for light mixtures;
wire thickness 1,6 mm, 24 wires

	#	↗ mm	🛒
☑	170040	250	1
☑	170041	300	1
☑	170042	350	1
☑	170043	400	1
☑	170044	450	1



BALLOONFORM mit schwarzem Kunststoffgriff
"Exoglas", Ruten aus Edelstahl, hitzebeständig
bis 220°C, wasserdicht, sehr handlich
Drahtstärke 1,5 mm, 12 Drähte

BALLOON-SHAPED black handle made of
"exoglas", wires stainless steel, heat resistant
up to 220°C, water proof, easy handling
wire thickness 1,5 mm, 12 wires

	#	↗ mm	🛒
	170016	450	1

DE	RÜHRBESEN
GB	WHISKS
IT	FRUSTE
ES	BATIDORES

Material: Edelstahl; schwarzer thermo-
plastischer, Griff mit Aufhängeöse,
hitzebeständig bis 200°C, wasserdicht;
spülmaschinenfest; schwere Qualität,
Drahtstärke 2,0 mm; 16 Drähte

made of stainless steel; black coloured
thermoplastic handle, hook, heat resistant
up to 200°C, water proof, dishwasher proof;
heavy quality,
wire thickness 2,0 mm; 16 wires



1

	#	↗ mm	🛒
☑	170070	250	12
☑	170071	300	12
☑	170072	350	12
☑	170073	400	12
☑	170074	450	12
☑	170075	500	12

Drähte gefasst, für schwere Massen,
Drahtstärke 2,3 mm, 16 Drähte

wires connected – for heavy mixtures
wire thickness 2,3 mm, 16 wires



9

	#	↗ mm	🛒
☑	170050	350	1
☑	170051	400	1
☑	170052	450	1
☑	170053	500	1
☑	170054	600	1

mit schwarzem Kunststoffgriff "Exoglas",
Ruten aus Edelstahl, hitzebeständig bis 220°C,
wasserdicht, sehr handlich
Drahtstärke 1,8 mm, 16 Drähte

black handle made of "exoglas",
wires stainless steel, heat resistant up to 220°C,
water proof, easy handling
wire thickness 1,8 mm, 16 wires



	#	↗ mm	🛒
	170010	250	1
	170011	300	1
	170012	350	1
	170013	400	1
	170014	450	1
	170015	500	1

DE	FLACHBESEN
GB	FLAT WHISK
IT	FRUSTE
ES	BATIDORES

Speziell für das Unterheben von schweren
Massen und Saucen, Cremes und Mehl.
Auch für Fettgebäck bestens geeignet.
Drahtstärke 2,0 mm, 4 Drähte

Especially for mixing heavy masses and
sauces, creams and flour.
wire thickness 2,0 mm, 4 wires



	#	↗ mm	🛒
☑	170079	270	12



DE	FRÜCHTE ABLAUF-SET, RUND				SET
GB	FRUIT STAINER SET, ROUND				
IT	SET PER SCOLARE LA FRUTTA				
ES	BOL Y TAMIZ PARA FILTRAR LOS ZUMOS DE LAS FRUTAS				

Material: PP, weiß, bruchsicher und hygienisch, Sieb mit praktischem Griff, alle Komponenten einzeln erhältlich

made of PP, white, break resistant, hygienic, stackable, strainer with 2 handles, each part available separately

#		Ø mm	l		
290040	Schüssel/round bowl	360	9,0	1	
200022	Seiher/strainer	280		1	



DE	RÜHRCHÜSSELN				
GB	MIXING BOWLS				
IT	BACINELLE TONDE, POLIPROPILENE				
ES	CALDEROS SEMIESFÉRICOS, PLÁSTICO				

Material: PP, natur-weiß, bruchsicher und hygienisch, stapelbar, auch für Mikrowellen-geräte geeignet

made of PP, natural white, break resistant, hygienic, stackable, usable also for microwave

#	l	Ø mm	↑ mm		
290000	1,0	190	79	1	
290010	2,5	240	115	1	
290020	4,5	280	135	1	
290030	6,0	325	147	1	
290040	9,0	360	165	1	
290050	13,0	400	185	1	



DE	DECKEL			
GB	LIDS			
IT	COPERCHI			
ES	TAPA			

Material: PP

made of PP



#	für / for #	Ø mm		
290070	290000 (1,0 l)	190	1	
290071	290010 (2,5 l)	240	1	
290072	290020 (4,5 l)	280	1	
290073	290030 (6,0 l)	325	1	
290074	290040 (9,0 l)	360	1	
290075	290050 (13,0 l)	400	1	

DE	SCHÜSSELN
GB	BOWLS
IT	BACINELLE TONDE, POLIPROPILENE
ES	CALDEROS SEMIESFÉRICOS, PLÁSTICO

Material: PP, weiß, tiefe Form

made of PP, white, deep moulded

#	Ø mm	↑ mm	♻️ l	🛒
221020	160	78	0,75	1
221021	200	96	1,6	1
221022	240	110	2,6	1
221023	280	120	4,5	1
221024	320	137	6,5	1
221025	360	159	9,5	1
221026	400	168	12,5	1



DE	SEIHER
GB	STRAINER
IT	COLAPASTA, POLIPROPILENE
ES	COLADOR, PLÁSTICO

Material: PP, weiß, 2 Muschelgriffe
passende Schüssel Art-Nr. 221026+290040made of PP, 2 shell shaped grips,
suitable bowls code 221026+290040

#	↑ Ø mm	↓ Ø mm	↑ mm	🛒
200022	360	280	185	1



9

DE	TEIGWANNEN RECHTECKIG
GB	DOUGH CONTAINERS RECTANGULAR
IT	CONTENITORI PER IMPASTO, RETTANGOLARI
ES	BANDEJA PARA MASA, RECTANGULAR

Material: PE, weiß

made of PE, white

#	♻️ l	↔ mm	🛒
200960	20	530 x 405 x 145	1
200962	12	440 x 320 x 155	1
NEW 200963	25	610 x 440 x 150	1



DE	TEIGWANNEN RUND
GB	DOUGH CONTAINERS ROUND
IT	CONTENITORI PER IMPASTO, TONDI
ES	BANDEJA PARA MASA, REDONDA

Material: PE, weiß

made of PE, white

#	♻️ l	Ø mm	↑ mm	🛒
200970	14	370	175	1
200971	19	420	150	1





DE	RÜHRSCHÜSSELN	CNS 18/10
GB	MIXING BOWLS	
IT	BACINELLE CONICHE	
ES	CALDEROS CÓNICOS	

Material: Edelstahl, mit abgerundetem Rand
Schüsselform: konisch

made of stainless steel, rolled edge
cone-shaped



#	Ø	↓ I	🛒
199002	160	0,5	1
199003	180	0,9	1
199004	200	1,2	1
199005	225	1,6	1
199006	235	2,0	1
199007	280	3,0	1
199008	320	5,0	1
199009	360	7,0	1
199010	395	8,2	1



DE	SCHLAGSCHÜSSELN	CNS 18/10
GB	MIXING BOWLS	
IT	BACINELLE SEMISFERICHE	
ES	CALDEROS SEMIESFÉRICOS	

Material: Edelstahl, mit abgerundetem Rand
Schüsselform: rund

made of stainless steel, rolled edge
round shape



#	Ø innen/inside	↓ I	🛒
199000	125	0,3	1
199011	140	0,5	1
199012	165	0,9	1
199013	185	1,25	1
199014	200	1,85	1
199015	230	2,6	1
199017	255	3,2	1
199018	280	4,5	1
199019	330	6,7	1



DE	MASCHINENSCHLAGKESSEL	CNS 18/10
GB	KETTLES FOR MIXING MACHINES	
IT	PENTOLE PER PLANETARIA	
ES	CALDEROS PARA BATIDORA	



Material: Edelstahl, mit zwei Griffen

made of stainless steel, with 2 handles

#	Ø	↑	↓ I	🛒
199420	260	200	10,0	1
199421	300	250	16,0	1
199422	320	300	20,0	1
199423	360	285	25,0	1
199424	360	350	32,0	1
199425	400	355	40,0	1

DE	HANDSCHLAGKESSEL	CNS 18/10
GB	MIXING BOWLS	
IT	BASTARDELLE SEMISFERICHE	
ES	CALDEROS CON ANSAS	

Material: Edelstahl, mit zwei Griffen made of stainless steel, 2 handles

#	Ø	↑	 l	
199400	220	120	2,7	1
199401	260	140	4,0	1
199402	320	180	9,5	1
199403	360	205	14,0	1
199404	400	215	18,0	1



DE	FUSS FÜR HANDSCHLAGKESSEL	CNS 18/10
GB	BASE FOR MIXING BOWLS	
IT	BASI PER BASTARDELLE	
ES	BASE PARA CALDEROS	

Material: Edelstahl made of stainless steel

#	Ø	für / for #	
199405	220	199402, 199403, 199404	1
199406	160	199400, 199401	1



DE	KASSEROLLE	
GB	SAUCEPAN	
IT	CASSERUOLA	
ES	CACEROLA	

Material: PP, weiß, mit geprägter Skala in Innenseite und zusätzl. blauem Skalendruck auf der Außenseite, bruchsicher und hygienisch, für Mikrowellengeräte geeignet
 Volumen: 2,0 Liter

made of PP, white, inside scale and blue printed litre and ml scale outside, break resistant, suitable for microwave
 volume: 2,0 ltr.

#	↗ mm	Ø	↑ mm	
290200	335	190	120	1

 Ausgießer beidseitig somit für Links- und Rechtshänder geeignet. / For right- and left handed.





NEW

DE	VORRATSDOSEN
GB	PLASTIC CONTAINERS
IT	CONTENITORI TONDI CON COPERCHIO
ES	CONTENEDORES REDONDOS CON TAPA

Material: Dose HD-PE, Deckel LD-PE
 Farbe natur, stapelbar
 Wasser- und Luftdichter Stülpedeckel
 Spülmaschinenfest, für Mikrowelle geeignet
 Temperaturbeständig von -20°C bis + 70°C

Made of: box HD-PE, lid LD-PE
 colour natural, stackable
 Water- and airtight snap-on lid
 Dishwasher safe, microwave safe
 Temperature resistant from -20°C to + 70°C

#	↔ mm	↕ ml	🛒
230040	103 x 103 x 64	500	20
230041	103 x 103 x 127	1000	16
230042	103 x 208 x 64	1000	18
230043	103 x 208 x 94	1500	20
230044	208 x 208 x 64	2000	20
230045	208 x 208 x 94	3200	14



DE	VORRATSDOSEN
GB	PLASTIC CONTAINERS
IT	CONTENITORI TONDI CON COPERCHIO
ES	CONTENEDORES REDONDOS CON TAPA

Material: PP, rund, mit Schraubverschluss made of PP, round, with screw top

#	↕ ml	Ø	↑ mm	🛒
230020	500	100	120	1
230021	1000	120	125	1



DE	VORRATSDOSEN
GB	PLASTIC CONTAINERS
IT	CONTENITORI QUADRATI CON COPERCHIO
ES	CONTENEDORES CUADRADOS CON TAPA

Material: Kunststoff, natur, inklusive dichtschießendem Deckel (Deckel nicht spülmaschinengeeignet)
 alle Größen stapelbar, bruchstabil

made of plastic, natural, including hermetically sealed lid (lid not dishwasher proof)
 all sizes stackable, break resistant

#	↕ l	→ mm	Tiefe/depth	↑ mm	🛒
230100	2,0	120	155	150	1
230110	3,0	120	155	210	1
230120	5,0	120	155	340	1



DE	WANDAUFHÄNGER
GB	WALL RACK
IT	SUPPORTO MURALE PER CONTENITORI
ES	SOPORTE MURAL PARA CONTENEDORES

Sehr stabile Ausführung, weiß beschichtet (Polyamid),
 passend für Dosen 2,0 l, 3,0 l und 5,0 l (Art-Nr. 230100, 230110 und 230120)

solid, coated in white plastic (Polyamide), suitable for containers 2,0 l, 3,0 l and 5,0 l (item-no. 230100, 230110 and 230120)

#	↗ mm	→ mm	↑ mm	🛒
230130	900	190	160	1

DE	FLASCHEN
GB	BOTTLES
IT	BOTTIGLIE
ES	FRASCOS

Material: PE, lebensmittelecht, transparent made of PE, food safe, transparent

#	ml	Ø	↑	
200194	50	28 x 51	79	1
200195	250	61	134	1
200196	500	78	162	1
200197	1000	97,5	223,5	1



9

DE	SPRÜHFLASCHEN
GB	SPRAYING BOTTLES
IT	BOTTIGLIA PER BAGUE
ES	FRASCOS NEBULIZADORES

Material: PE, lebensmittelecht, transparent, Verschluss gelocht (13 Löcher), mit Skala made of PE, food-proof, transparent, perforated cap (13 holes), with scale

#	l	↗ mm	→ mm	↑ mm	
200192	1,0	70	70	230	1



DE	DRUCKPUMPENZERSTÄUBER	
GB	COMPRESSED AIR SPRAYER	
IT	POLVERIZZATORE	
ES	PULVERIZADOR	

Flexibler Druckpumpenzerstäuber für einfaches Versprühen von Flüssigkeit durch Luftdruck. Handlich und vielseitig einsetzbar. Große Flächen können problemlos gleichmäßig eingesprüht werden. Druckaufbau durch Pumpstange.

100% Lebensmittelecht

Pressure sprayer for easy and flexible spraying of all liquids by air-pressure. Suitable for nearly all liquids. Large surfaces can be sprayed easily and even.

100% food safe

#	↔ mm	l	
153950	280 / 140	1,6	1



DE	KONFITÜREN-SCHÜSSELN
GB	JAM BOWLS
IT	BASTARDELLE PER MARMELATTA IN RAME
ES	CALDEROS PARA MERMELADA



Material: hochwertiges Kupfer,
Stärke 1-2 mm, mit 2 Griffen

made of high-quality copper,
thickness 1 – 2 mm, with 2 grips

#	Ø mm	↑ mm	📦 l	🛒
170120	360	130	10,0	1
170121	400	150	13,5	1

DE	ZUCKERTÖPFE
GB	SUGAR PANS
IT	CASSERUOLE PER ZUCCHERO IN RAME
ES	CACEROLAS PARA AZÚCAR



Material: hochwertiges Kupfer,
Stärke 1 – 2 mm

made of high-quality copper,
thickness 1 – 2 mm

#	Ø mm	↑ mm	📦 l	🛒
mit Kupfergriff / with copper handle:				
170135	120	70	0,75	1
170136	140	80	1,1	1
170137	160	90	1,8	1
170138	180	100	2,5	1
170139	200	110	3,5	1
mit Holzgriff / with wooden handle:				
170145	160	90	1,8	1
170146	180	100	2,5	1
170147	200	110	3,5	1
170148	Holzgriff einzeln / replacement wooden handle			1

DE	ZABAIONESCHÜSSELN
GB	ZABAGLIONE BOWLS
IT	CASSERUOLE PER ZABAIONE IN RAME
ES	CACEROLAS PARA SABAYÓN



Material: hochwertiges Kupfer, Stärke 1 – 2 mm,
Griff aus Messing

made of high-quality copper, thickness
1 – 2 mm, handle made of brass

#	Ø mm	↑ mm	📦 l	🛒
170140	160	120	1,8	1
170141	200	145	3,0	1

DE	SIRUP-SCHÜSSELN
GB	SYRUP BOWLS
IT	BASTARDELLE PER SCIROPPO
ES	CALDEROS PARA ALMÍBAR

Material: hochwertiges Kupfer, Stärke 1 – 2 mm, mit 2 Griffen
 made of high-quality copper, thickness 1 – 2 mm, with 2 handles

#	Ø mm	↑ mm	 l	
170116	260	130	4,6	1
170117	300	150	7,0	1
170118	350	180	10,0	1
170119	400	200	16,0	1



DE	EIWEISS-SCHÜSSELN
GB	EGG WHITE BOWLS
IT	BASTARDELLE IN RAME
ES	CUBETAS PARA BLANCO DE HUEVOS

Material: hochwertiges Kupfer, Stärke 1 – 2 mm
 made of high-quality copper, thickness 1 – 2 mm

#	Ø mm	↑ mm	 l	
mit Aufhängering / with suspension ring:				
170107	240	120	3,6	1
170108	260	130	4,6	1
170109	300	150	7,0	1
170110	350	180	10,0	1
170111	400	200	16,0	1
mit 2 Griffen / with 2 handles:				
170112	260	130	4,6	1
170113	300	150	7,0	1
170114	350	180	10,0	1
170115	400	200	16,0	1



9

 Nicht zum Kochen von Wasser geeignet. / Not suitable for boiling water.

DE	FUSS
GB	BASE FOR BOWLS
IT	BASE PER BASTARDELLE
ES	BASE PARA CALDEROS

Material: Edelstahl, für runde Schüsseln
 made of stainless steel, useable for round bowls

#	Ø mm	
170101	245	1



gilt für alle Kupfer-Produkte / applies to all copper products



Art. 200010 bis 200015



Art. 206011 bis 206015



206010

DE	MESSBECHER
GB	MEASURING CUPS
IT	CARAFFE GRADUATE
ES	JARRAS GRADUADAS, ASA CERRADA

Material: PP, Farbe natur, geprägte Skala und blauem Skalendruck, Liter- und Milliliter-Einteilung, bis 95°C erhitzen

made of PP, translucent, with stamped and blue printed litre and ml scale, temperature resistant up to 95°C

#		l	
206010	ohne Griff / without handle	0,12	10
200010	mit geschlossenem Griff / closed handle	0,25	25
200011	mit geschlossenem Griff / closed handle	0,5	16
200012	mit geschlossenem Griff / closed handle	1,0	12
200013	mit geschlossenem Griff / closed handle	2,0	12
200014	mit geschlossenem Griff / closed handle	3,0	10
200015	mit geschlossenem Griff / closed handle	5,0	5
206011	mit offenem Griff / open handle	0,5	16
206012	mit offenem Griff / open handle	1,0	12
206013	mit offenem Griff / open handle	2,0	12
206014	mit offenem Griff / open handle	3,0	10
206015	mit offenem Griff / open handle	5,0	5



DE	MESSBECHER-DECKEL
GB	MEASURING CUPS-LIDS
IT	COPERCHI
ES	TAPA

#	für / for #	
206112	200012 + 206012 / 1,0 (l)	32
206113	200013 + 206013 / 2,0 (l)	16

DE	MESSBECHER
GB	MEASURING CUPS
IT	CARAFFE GRADUATE, IMPILABILI
ES	JARRAS GRADUADAS, APILABLES

Material: PP, Farbe natur, mit offenem Griff, stapelbar, Liter- und Milliliter-Einteilung, bis 95°C erhitzen

made of PP, translucent, with open handle, stackable, with litre- and ml-scale, temperature resistant up to 95°C



#	l	
200149	0,5	10
200150	1,0	10
200170	2,0	10
200179	3,0	10

DE	TRICHTER
GB	FUNNELS
IT	IMBUTI
ES	EMBUDOS

Material: HD-PE, Farbe natur, gerade made of high density polyethylene,

mit Entlüftungslippen und Aufhängeöse with air vent slot, with suspension loop

#	Ø mm	Auslaufende / run out Ø mm	
250001	50	3	1
250002	60	8	1
250003	80	11	1
250004	100	12	1
250005	120	12	1
250006	140	15	1
250007	164	17	1



**mit Überlauftrand und Phosphor-
bronze-Sieb, Aufhängeöse**

**with over-flow and phosphor-bronze
sieve, with suspension loop**

#	Ø mm	Auslaufende / run out Ø mm	
250008	168	17	1
250009	208	20	1





DE	MEHL- UND GEWÜRZSCHAUFELN
GB	FLOUR SCOOPS
IT	SESSOLE
ES	RECOGEDORES LIBRADORES

Material: PE, Farbe natur

made of PE , transparent

#	↗ mm	📏 l	🛒
200023	187	110	12
200024	250	230	12
200025	310	470	6
200026	350	725	3
200027	400	1390	3

📌 HACCP-Farben auf Anfrage. / HACCP-colours open request.



Material: PE, Farbe schwarz

made of PE , black

#	↗ mm	📏 l	🛒
200802	250	230	12



DE	MESSSCHAUFELN, FREI STEHEND
GB	MEASURING SCOOPS, FREE STANDING
IT	SESSOLE CON BASE PIATTA
ES	RECOGEDORES LIBRADORES PARA HARINA

Material: PP, weiß

Made of PP, color white.

Ausführung: stehende Schaufel, auch für Flüssigkeiten

Execution: free-standing scoops, suitable for liquids

#		↗ mm	📏 l	🛒
200350	○ weiss / white	135	25	12
200351	○ weiss / white	160	50	12
200352	○ weiss / white	200	100	12
200353	○ weiss / white	260	250	6
200354	○ weiss / white	315	500	6
200355	○ weiss / white	385	1000	6
200346	● rot / red	200	100	12
200347	● rot / red	260	250	6
200348	● blau / blue	200	100	12
200349	● blau / blue	260	250	6



DE	MEHL- UND GEWÜRZSCHAUFELN
GB	FLOUR SCOOPS
IT	SESSOLE CON BASE PIATTE IN ALLUMINIO
ES	RECOGEDOR LIBRADOR PARA HARINA, ALUMINIO

Material: Aluguß mit Außengriff, aus einem Stück gegossen, sehr stabile Formen, praktisch und handlich im Gebrauch, hygienisch

made of cast aluminum, in one piece, solid, easy handling, hygienic

#	↗ mm	⚖ l	🛒
180202	210	130	1
180210	250	250	1
180220	265	285	1
180230	290	375	1
180240	310	450	1
180250	335	500	1
180260	350	800	1
180270	400	1500	1
180280	430	2500	1



#	↗ mm	⚖ l / g	Griff / handle	🛒
180310	255	0,35 / 330	oben / on top	1
180320	315	0,65 / 450	oben / on top	1
180330	385	1,2 / 850	oben / on top	1
180340	270	0,5 / 350	mittig / middle	1
180350	310	0,85 / 600	mittig / middle	1
180360	385	2,0 / 1400	mittig / middle	1



9

polierte Oberfläche

polished surface

#	↗ mm	⚖ ml	🛒
✓ 180400	145	90	1
✓ 180410	185	150	1
✓ 180420	210	180	1
✓ 180430	245	355	1
✓ 180440 *	310	720	1
✓ 180450 *	350	1000	1
✓ 180460 *	400	1900	1



* freistehend / free-standing

DE	SACKSCHAUFELN
GB	FLOUR SCOOPS
IT	SESSOLE CON BASE TONDA E MANIGLIA ROVESCATA IN ALLUMINIO
ES	RECOGEDOR LIBRADOR PARA HARINA CON MANGO INVERTIDO, ALUMINIO

Material: Aluguß mit Außengriff, Griff genietet, sehr stabile Form, praktisch und handlich im Gebrauch, hygienisch

made of cast aluminum, handle riveted, solid, easy handling, hygienic

#	↗ mm	⚖ l	🛒
180370	310	2200	1



Material: Edelstahl, mit Außengriff aus Gummi, sehr schwere Ausführung

made of stainless steel, handle riveted made of rubber, solid

#	↗ mm	⚖ l	🛒
180300	280	2000	1





DE	SIEBE FÜR PUDERZUCKER UND KAKAO
GB	SIEVES FOR POWDERED SUGAR AND COCOA
IT	SETACCI PER ZUCCHERO A VELO E CACAO
ES	TAMIZES PARA AZÚCAR EN POLVO CONGELA Y CACAO

Material: Edelstahl, Sieb aus Edelstahl made of stainless steel, sieve made of stainless steel

#	Ø mm	
199069	100	1

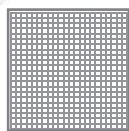

DE	PUDERZUCKERSIEBE
GB	SIEVES FOR POWDERED SUGAR
IT	SETACCI PER ZUCCHERO A VELO
ES	TAMIZES PARA AZÚCAR EN POLVO CONGELA

Material: Edelstahl, feines Gewebe made of stainless steel, fine meshes

#	Ø mm	mm	↑ mm	
199052	160	0,2	65	1
199053	190	0,2	65	1
199054	210	0,2	65	1
199055	240	0,2	65	1
199056	260	0,2	65	1
199057	280	0,2	65	1
199058	300	0,2	65	1



stabiler Kunststoff, mit praktischen Rillen (verhindert das Abrutschen), **keine Metallklammern**, Maschen aus Edelstahl, spülmaschinentauglich solid plastic, with convenient flutes (avoid slip off), **no staples**, stainless steel mesh, dishwasher safe

#	Ø mm	↑ mm / ↓ mm	mm	↓ mm	
200635	185	107 / 95	0,5	0,2	6

DE	MEHL- UND ZUCKERSIEBE
GB	FLOUR AND SUGAR SIEVES
IT	SETACCI PER FARINA E ZUCCHERO
ES	TAMIZES PARA HARINA

Material: PP, weiß, Nylon-Netzmaschen, einfach zu reinigen

PP, white, nylon meshes, easy to clean

#	Ø mm	↑ mm	⊞ mm	🛒
200240	240	80 / innen: 65	0,5	1
200241	240	80 / innen: 65	1,0	1
200300	300	90 / innen: 70	0,5	1
200301	300	90 / innen: 70	1,0	1



stabiler Kunststoff, mit praktischen Rillen (verhindert das Abrutschen), **keine Metallklammern**, Maschen aus Edelstahl, spülmaschinentauglich

solid plastic, with convenient flutes (avoid slip off), **no staples**, stainless steel mesh, dishwasher proof

#	Ø mm	↑ mm	⊞ mm	⊥ mm	🛒
200634	305	115 / innen: 100	0,50	0,20	6
200633	305	115 / innen: 100	0,85	0,24	6
200632	305	115 / innen: 100	1,20	0,28	6
200631	305	115 / innen: 100	1,80	0,34	6
200630	305	115 / innen: 100	2,80	0,45	6



9

für trockenes Siebgut
Material: Ring und Metallgewebe aus Edelstahl

for dry ingredients
ring and meshes made of stainless steel

#	Ø mm	↑ mm	⊞ mm	⊥ mm		🛒
199210	220	55	0,45	0,22	Mehl, sehr fein / flour, very fine	1
199211	220	55	0,60	0,25	Mehl, fein / flour, fine	1
199212	220	55	0,84	0,28	Mehl, mittel / flour, medium	1
199220	400	80	0,45	0,22	Mehl, sehr fein / flour, very fine	1
199221	400	80	0,60	0,25	Mehl, fein / flour, fine	1
199222	400	80	0,84	0,28	Mehl, mittel / flour, medium	1
199223	400	80	6,8	1,0	Streusel, grob / coarse	1





DE	AUSBACKSCHIESSER
GB	OVEN BLADES
IT	PALE PER FORNO IN ALLUMINIO
ES	PALA PARA HORNEAR

Material: Aluminium, Randhöhe 30 mm
Aufnahme-Stiel: 26 x 26 mm

made of aluminum, height of edge 30 mm
support shaft: 26 x 26 mm



#	↔ mm	
155500	580 x 470	1

Material: Buchenholz

made of beech wood



#	↗ mm	→ mm	
203400	500	120	1
203401	500	140	1
203402	500	160	1
203403	500	180	1
203404	500	200	1
203405	500	240	1
203406	500	300	1
203407	500	320	1
203408	500	340	1
203409	600	160	1
203410	650	200	1



DE	TORTENRINGE RUND
GB	TART RINGS ROUND
IT	ANELLI PER TORTE
ES	AROS PARA TARTAS

Material: Edelstahl

made of stainless steel

mit Borde

with folded rim



#	Ø mm	↑ mm	
162080	80	20	5
162100	100	20	5
162120	120	20	5
162140	140	20	5
162160	160	20	5
162180	180	20	5
162200	200	20	5
162220	220	20	5
162240	240	20	5
162260	260	20	5
162280	280	20	5
162300	300	20	5
162320	320	20	5
162340	340	20	5

ohne Borde

without folded rim



#	Ø mm	↑ mm	
163075	75	40	5
163080	80	45	5
163120	120	45	5
163140	140	45	5
163160	160	45	5
163180	180	45	5
163200	200	45	5
163220	220	45	5
163240	240	45	5
163260	260	45	5
163280	280	45	5
163300	300	45	5

ohne Borde

without folded rim



#	Ø mm	↑ mm	
164120	120	60	5
164140	140	60	5
164160	160	60	5
164180	180	60	5
164200	200	60	5
164220	220	60	5
164240	240	60	5
164260	260	60	5
164280	280	60	5
164300	300	60	5

DE	DESSERT- UND TORTENRINGE
GB	DESSERT AND TART RINGS
IT	ANELLI PER DOLCI E TORTE
ES	AROS PARA POSTRES Y TARTAS

Material: Aluminium ALMG3, nahtgeschweißt made of aluminum, welded seam

#	Ø mm	↑ mm	↓ mm	
156753	75	30	1,0	5
156754	75	40	1,0	5
156853	85	30	1,0	5
156953	95	30	1,0	5
156165	160	50	2,0	5
156185	180	50	2,0	5
156186	180	60	2,0	5
156187	180	70	2,0	5
156205	200	50	2,0	5
156206	200	60	2,0	5
156207	200	70	2,0	5
156225	220	50	2,0	5
156226	220	60	2,0	5
156227	220	70	2,0	5
156245	240	50	2,0	5
156246	240	60	2,0	5
156247	240	70	2,0	5
156265	260	50	2,0	5
156266	260	60	2,0	5
156267	260	70	2,0	5
156285	280	50	2,0	5
156286	280	60	2,0	5
156287	280	70	2,0	5



9

 Sonderformate auf Anfrage! / Special sizes upon request!

DE	TORTENRING-SET
GB	SET OF TART RINGS FOR CAKE STANDS
IT	SET DI ANELLI PER TORTE
ES	JUEGO DE AROS PARA TARTAS

aus Aluminium ALMG3, nahtgeschweißt, Stärke 2 mm für 3-, 4-, 5- und 7-teiligen Tortenständer welded seam, polished, thickness 2 mm for cake stands with 3 / 4 / 5 / 7 floors

#	↑ mm		
156013	60	3-teilig / 3-floors	1 Set
156014	60	4-teilig / 4-floors	1 Set
156015	60	5-teilig / 5-floors	1 Set
156017	60	7-teilig / 7-floors	1 Set



DE	TORTENSCHNEIBEN
GB	CAKE PLATES
IT	DISCHI PER TORTE
ES	DISCOS PARA TARTAS

Material: Aluminium ALMG3,
mit Aufhängeloch

made of aluminum, with hanging loop



#	Ø mm	mm	
156241	240	1,0	10
156261	260	1,0	10
156281	280	1,0	10
156282	280	1,5	10
156301	300	1,0	10
156302	300	1,5	10
156321	320	1,0	10
156322	320	1,5	10

Material: PS, weiß, mit Aufhängeloch

made of PS, white, with hanging loop



#	Ø mm	mm	
203110	200	3,0	1
203111	220	3,0	1
203112	240	3,0	1
203113	260	3,0	1
203114	280	3,0	1
203115	300	3,0	1
203116	320	3,0	1
203117	340	3,0	1

DE	TORTENSCHNEIBENSTÄNDER
GB	SUPPORT FOR CAKE PLATES
IT	SUPPORTO PER DISCHI PER TORTE
ES	SOPORTE PARA DISCOS DE TARTAS

weiße Kunststoffbeschichtung, 2 seitliche Griffe

white plastic coating, handles on both sides



#	mm	
157010	500 x 200 x 180	1

DE	TORTENRINGE
GB	TART RINGS
IT	ANELLI PER TORTE
ES	AROS PARA TARTAS

Material: Aluminium ALMG3,
nahtgeschweißt, Dicke 2,0 mm

made of aluminum, welded seam,
thickness 2,0 mm

ovale Form – für Quarkstollen

oval

#	↗ mm	→ mm	↑ mm	
155050	235	105	40	5
155051	180	105	50	5



Herz

heart

#	Ø mm	↑ mm	
155070	160	50	5
155071	180	50	5
155072	200	50	5
155073	220	50	5
155074	240	50	5



9

DE	BACKRAHMEN "HERZ"
GB	BAKING FRAME "HEART"
IT	TELAIO PER TORTE, "CUORE", REGOLABILE
ES	AROS PARA TARTAS, CORAZÓN AJUSTABLE

Material: Edelstahl (0,5 – 1,0 mm),
ausziehbar / verstellbar

made of stainless steel (0,5 – 1,0 mm),
extensible

#	↔ mm	↑ mm	
199160	220 – 270	70	1
199161	290 – 380	70	1
199162	430 – 500	70	1



DE	TORTENRING RUND, VERSTELLBAR
GB	CAKE RING ROUND, ADJUSTABLE
IT	ANELLI PER TORTE ROTONDI, REGOLABILI
ES	AROS PARA TARTAS, AJUSTABLE

Material: Edelstahl, Materialstärke 1,2 mm

made of stainless steel, thickness 1,2 mm

#	↔ mm / mind.	↔ mm / max.	↑ mm	
199986	180	300	50	1
199987	180	300	60	1
199988	300	500	60	1



DE	DESSERT- / TORTENRINGE
GB	DESSERT / TART RINGS
IT	ANELLI PER TORTE E DESSERT
ES	AROS PARA TARTAS

Material: Edelstahl

made of stainless steel

#		↔ mm	↑ mm	
155060	Achteck / octagon	Ø: 160	50	5
155100	Sechseck / hexagon	Ø: 160	50	5
155110	Sechseck / hexagon	Ø: 180	50	5
155120	Sechseck / hexagon	Ø: 200	50	5
155200	Herz / heart	Ø: 180	50	5
155210	Herz / heart	Ø: 200	50	5
155220	Herz / heart	Ø: 230	50	5
155300	Dreieck / triangle	L: 160	50	5
155310	Dreieck / triangle	L: 180	50	5
155320	Dreieck / triangle	L: 200	50	5

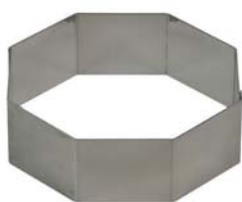

Art.-Nr. 155060



Art.-Nr. 155100 bis 155120



Art.-Nr. 155200 bis 155220



Art.-Nr. 155300 bis 155320

#		↗ mm	↑ mm	⏊ mm	
155330	Tropfen / tear-drop	160	50	1,2	5
155331	Tropfen / tear-drop	180	50	1,2	5
155332	Tropfen / tear-drop	200	50	1,2	5
155340	Dreieck, gewölbt / triangle, convex	160	50	1,2	5
155341	Dreieck, gewölbt / triangle, convex	180	50	1,2	5
155342	Dreieck, gewölbt / triangle, convex	200	50	1,2	5
155350	Viereck, gewölbt / square, convex	140	50	1,0	5
155351	Viereck, gewölbt / square, convex	160	50	1,0	5
155352	Viereck, gewölbt / square, convex	180	50	1,0	5



Art.-Nr. 155330 bis 155332



Art.-Nr. 155340 bis 155342



Art.-Nr. 155350 bis 155352

DE	TORTENRAHMEN QUADRAT
GB	TART RINGS SQUARE
IT	TELAJ PER TORTE, QUADRATI
ES	AROS PARA TARTAS, CUADRADO

Material: Edelstahl

made of stainless steel

#	↗ mm	→ mm	↑ mm	
155360	100	100	40	5
155361	100	100	50	5
155362	120	120	40	5
155363	120	120	50	5
155364	140	140	40	5
155365	140	140	50	5
155366	160	160	40	5
155367	160	160	50	5
155368	180	180	40	5
155369	180	180	50	5
155370	200	200	40	5
155371	200	200	50	5
155372	220	220	40	5
155373	220	220	50	5
155374	240	240	40	5
155375	240	240	50	5
155376	260	260	40	5
155377	260	260	50	5
155378	280	280	40	5
155379	280	280	50	5
155356	300	300	40	5
155357	300	300	50	5



9

DE	BACKRAHMEN RECHTECKIG, VERSTELLBAR
GB	CAKE RING RECTANGULAR, ADJUSTABLE
IT	TELAJ PER TORTE, RETTANGOLARI, REGOLABILI
ES	AROS PARA TARTAS, RECTÁNGULO, AJUSTABLE

Material: Edelstahl, Materialstärke 1,2 mm

made of stainless steel, thickness 1,2 mm

#	↔ mm (mind.)	↔ mm (max.)	↑ mm	
155400	215 x 115	405 x 200	80	1
155410	430 x 290	840 x 560	50	1
155420	300 x 300	570 x 560	50	1
155430	216 x 310	405 x 605	50	1



DE	SCHNITTEN-/BACKRAHMEN RECHTECKIG
GB	TART RINGS RECTANGULAR
IT	TELAJ PER TORTE, RETTANGOLARI
ES	AROS PARA TARTAS, RECTÁNGULO

Material: Edelstahl
 Materialstärke: 1,5 mm

made of stainless steel
 thickness: 1,5 mm

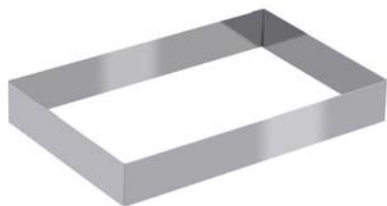

Art. 155380 bis 155391



Art. 155399

#	↗ mm	→ mm	↑ mm	
155380	140	240	40	5
155381	140	240	50	5
155382	160	260	40	5
155383	160	260	50	5
155384	180	280	40	5
155385	180	280	50	5
155386	220	300	40	5
155387	220	300	50	5
155388	260	380	40	5
155389	260	380	50	5
155390	300	400	40	5
155391	300	400	50	5
155399	380	580	50	5

DE	TORTENBODENSÄGE
GB	TART / CAKE SAW
IT	LIRE PER PAN DI SPAGNA
ES	CORTADOR DE PASTELES

Material: Edelstahl, mit drei Sägeblättern,
 max. Höhe der Sägeblätter 80 mm

made of stainless steel, with three saw blades,
 max. height of the saw blades 80 mm



#	↗ mm	⏏ mm	↑ mm	
153500	460	430	235	1
153510	Ersatzblatt / spare part blade			1

Material: Rahmen aus lackiertem Stahl, 2 Sägeblätter aus Edelstahl. Messer in der Höhe verstellbar (max. Abstand 50 mm)

frame made of steel lacquered, 2 saw blades height adjustable (max. 50 mm distance)



#	↗ mm	⏏ mm	↑ mm	
153550	460	430	160	1
153351	Ersatzblatt / spare part blade			1
153560	595	560	165	1
153352	Ersatzblatt / spare part blade			1

DE	DESSERTRING
GB	DESSERT RING
IT	ANELLI PER DOLCI
ES	ARO PARA POSTRES

NICHT zum Backen geeignet!
NOT for baking!



Material: PS, Farbe Elfenbein
Nicht zum Backen im Ofen geeignet!

made of PS, ivory
Not suitable for baking in ovens!

#	Ø mm	↑ mm	
200950	75	30	20

Material: Reinaluminium, nahtgeschweißt, extra stark

made of pure aluminum, welded seam, extra strong

#	Ø mm	↑ mm	∓ mm	
156075	75	30	2,0	5
156076	75	40	2,0	5



“MINI”

Material: Edelstahl; Materialstärke: 0,8 mm

“MINI”

made of stainless steel; thickness: 0,8 mm

#		↔ mm	↑ mm	
155450	Rund / round	Ø 70	45	1
155451	Oval / oval	L: 74 x B: 56	45	1
155452	Tropfen / drop	L: 77 x B: 54	45	1
155453	Dreieck / triangle	B: 68	45	1
155454	Herz / heart	H: 55 x B: 67	45	1
155455	Sechseck / hexagon	B: 54	45	1
155456	Quadrat / square	B: 54	45	1

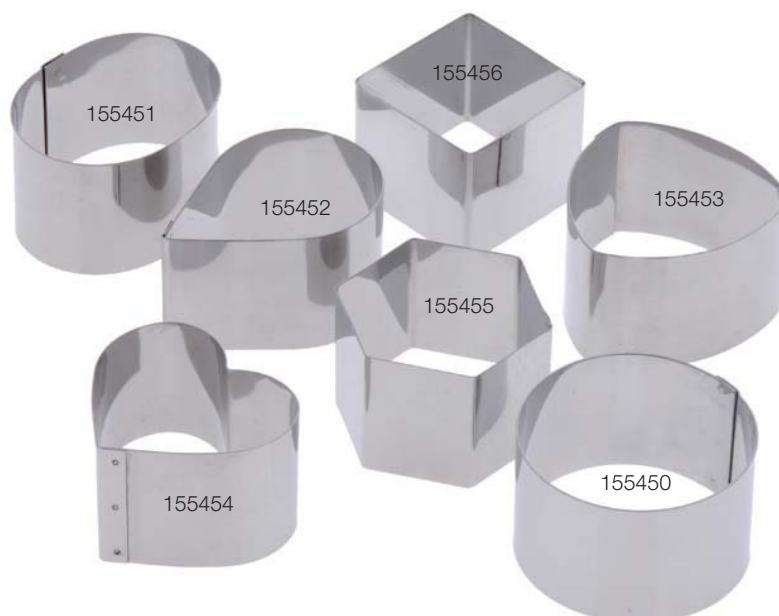



DE	TORTENEINTEILER
GB	TART MARKERS
IT	SEGNAPORZIONI PER TORTE
ES	MARCADOR DE PASTELES

EINSEITIG

Material: Edelstahl, sehr stabile Ausführung, Durchmesser 330 mm, Höhe 28 mm

SINGLE-SIDED

made of stainless steel, very strong quality, diameter 330 mm, height 28 mm

#	Teilungen / pieces	
120108	8	1
120110	10	1
120112	12	1
120114	14	1
120116	16	1
120118	18	1

DOPPELSEITIG

Material: Edelstahl, sehr stabile Ausführung, mit 2 Handgriffen Durchmesser 330 mm, Höhe 53 mm

DOUBLE-SIDED

made of stainless steel, very strong quality, 2 grips diameter 330 mm, height 53 mm



#	Teilungen / pieces	
120190	8/12	1
120191	10/12	1
120192	10/14	1
120193	10/16	1
120194	12/14	1
120195	12/16	1

EINSEITIG

Material: PP, elfenbein, mit 2 Handgriffen, Durchmesser 265 mm

SINGLE-SIDED

made of PP, ivory, 2 grips, diameter 265 mm



#	Teilungen / pieces	
220108	8	1
220110	10	1
220112	12	1
220114	14	1
220116	16	1
220118	18	1
220119	20	1

DOPPELSEITIG

Material: PP, elfenbein, mit 2 Handgriffen, Durchmesser 265 mm

DOUBLE-SIDED

made of PP, ivory, 2 grips, diameter 265 mm



#	Teilungen / pieces	
220128	8/12	1
220120	12/16	1
220122	14/16	1
220124	12/18	1
220126	14/18	1

DE	TORTENGITTER
GB	GRATES
IT	GRIGLIE
ES	REJILLA

Material: Edelstahl made of stainless steel

#		Ø mm	
156115	"Karo" mit Füßen / "square" pattern, with feet	320	1
156116	"Karo" mit Füßen / "square" pattern, with feet	360	1
156128	"Spirale" ohne Füße / "spiral" pattern, without feet	320	1
156129	"Spirale" ohne Füße / "spiral" pattern, without feet	360	1
156130	"Spirale" mit Füßen / "spiral" pattern, with feet	320	1
156131	"Spirale" mit Füßen / "spiral" pattern, with feet	360	1



Art.-Nr. 156115 + 156116



Art.-Nr. 156128 + 156129



Art.-Nr. 156130 + 156131

Material: Edelstahl, extra stabile Ausführung, mit 3 Traversen, mit Füßen made of stainless steel, very strong quality, with 3 traverses and feet

#	↗ mm	→ mm	
156124	590	390	1



9

DE	PRALINEN- / TRÜFFELGITTER
GB	CHOCOLATE / TRUFFLE GRATES
IT	GRIGLIE PER CIOCCOLATINI E TARTUFFI
ES	REJILLA PARA PRALINÉS Y TRUFAS

Material: Edelstahl made of stainless steel,
Design: „Karo“, mit Füßen design: "square" pattern, with feet
Höhe: 28 mm Height: 28 mm

#	↗ mm	→ mm	⊞ mm	⊥ mm	
156125	440	315	10 x 10	1	1
156126	580	390	10 x 10	1	1



DE	GRILLROSTE
GB	GRIDS
IT	GRIGLIE
ES	REJILLAS

Material: Edelstahl Made of stainless steel

#		↗ mm	→ mm	⊞	Ø mm	Drähte / Ø Draht mm	
156110		600	400	2	6	24 / 3	1
156111	GN 1/1	530	325	1	7	20 / 3	1
156112	GN 2/3	354	325	1	5	15 / 2	1
156113	GN 2/1	650	530	3	6	32 / 2	1





DE	MARZIPAN-MODELLIERSET KLEIN
GB	MARZIPAN MODELLING SET SMALL
IT	SET 9 PEZZI PER MARZAPANE, PLASTICA
ES	JUEGO DE ÚTILES PARA MAZAPÁN, PEQUEÑO (9 U.)

Material: PP
 Set bestehend aus 2 Strukturbrettern, 1 Marzipanmesser, 6 verschiedene Modellierstäbe, in stabiler Box

made of PP
 set consisting of 2 boards, 1 knife and 6 modelling tools, in solid box made of plastic

#			
227100	Set 9-teilig / set 9 pieces	1	



DE	MARZIPAN-MODELLIERSET GROSS
GB	MARZIPAN MODELLING SET LARGE
IT	SET 15 PEZZI PER MARZAPANE, PLASTICA
ES	JUEGO DE ÚTILES PARA MAZAPÁN, GRANDE (15 U.)

Material: PP
 Set bestehend aus 2 Strukturbrettern, 1 Marzipanmesser, 12 verschiedene Modellierstäbe, in stabiler Box

made of PP
 set consisting of 2 boards, 1 knife and 12 modelling tools, in solid box made of plastic

#			
227200	Set 15-teilig / set 15 pieces	1	



DE	MARZIPAN-STRUKTURBRETT
GB	MARZIPAN BOARD
IT	TAGLIERE PER MARZAPANE, SET DA 2 PEZZI
ES	PLANCHA PARA MAZAPÁN, JUEGO DE 2

Material: PP
 made of PP

#			
228101	Set 2-teilig / set 2 pieces	1	



DE	MARZIPANMESSER
GB	MARZIPAN KNIFE
IT	COLTELLO PER MARZAPANE
ES	CUCHILLO PARA MAZAPÁN

Material: PP
 made of PP

#	↗ mm		
228102	260	1	

DE	MARZIPAN-MODELLIERSTÄBE
GB	MARZIPAN MODELLING TOOLS
IT	ATTREZZATURE PER MARZAPANE
ES	JUEGO DE ÚTILES PARA MAZAPÁN

Material: PP

made of PP

#	Nr. / no.	
228200	1	1
228201	2	1
228202	3	1
228203	4	1
228204	5	1
228205	6	1
228206	7	1
228207	8	1
228208	9	1
228209	10	1
228210	11	1
228211	12	1

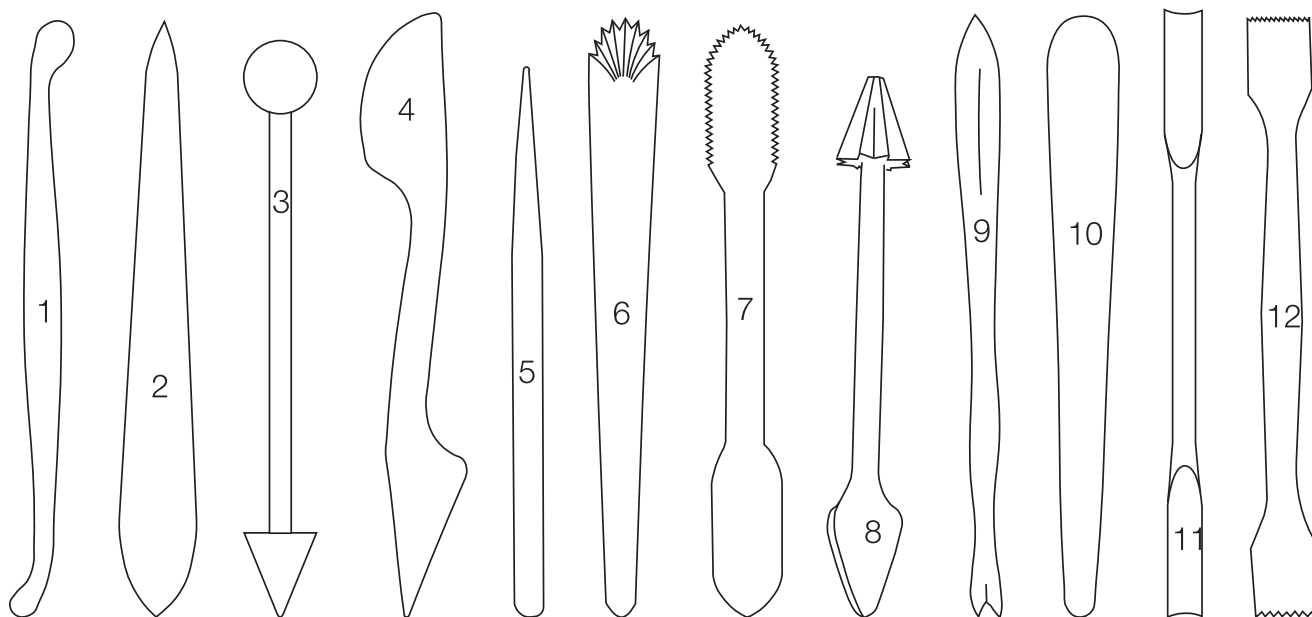

9

DE	MARZIPAN-MODELLIERSTÄBE
GB	MARZIPAN MODELLING TOOLS
IT	SET PER MARZAPANE
ES	JUEGO DE ÚTILES PARA MAZAPÁN

Material: PP

made of PP

#	Nr. / no.		
228103	2, 5, 7, 9, 10, 12	6 Stäbe/sticks	1
228109	1, 3, 4, 6, 8, 11	6 Stäbe/sticks	1
228104	1, 2, 3, 4, 5, 6, 7, 8, 9, 10, 11, 12	12 Stäbe/sticks	1



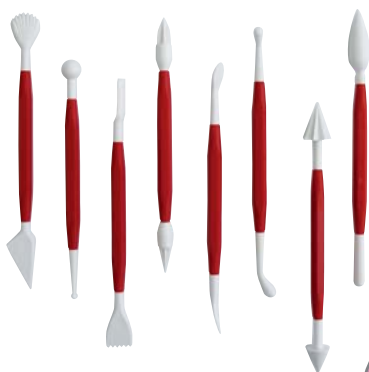

DE	MODELLIERSET
GB	MODELLING SET
IT	SET 8 PEZZI PER MARZAPANE, PLASTICA
ES	JUEGO DE ÚTILES, PEQUEÑO (8 U.)

Kunststoff, Länge: 165 mm, made of plastic, 165 mm length,
 Farbe: rot / weiss color: red / white

#		
166140	Set 8-teilig / set 8 pieces	1 Set



DE	GLÄTTER FÜR FONDANT
GB	CAKE POLISHER FOR SUGAR PASTE
IT	STENDI PASTA PER FONDANT
ES	ESPATOLA PARA FONDANT (PASTA DE AZUCAR)



Kunststoff, weiss made of white plastic

#	↔ mm	
166130	160 x 80	1



DE	GLASURTRICHTER
GB	GLAZE FUNNEL
IT	IMBUTO PER GLASSA
ES	EMBUDO AZUCAR



Material: Griff und Trichter aus Edelstahl, Handle and funnel made of stainless steel,
 Boden: Kunststoff, bottom made of plastic
 Lochdurchmesser: 5 mm, Hole diameter 5 mm
 für flüssiges Fondant mit Dosiermechanik for liquid fondant, dosing mechanism

#		Ø mm	↑ mm	
199960	1,0	135	150	1



geöffnet – Ansicht von innen
 open – interior view

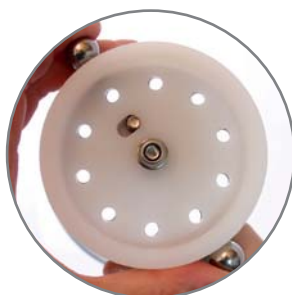

geöffnet / open



geschlossen / closed

DE	SCHILLERLOCKENFORMEN FLACH
GB	CREAM HORN MOULDS FLAT
IT	CORNETTI PIATTI
ES	MOLDES PARA CUCURUCHOS, RECTOS

Material: Edelstahl

made of stainless steel

#	↗ mm	Ø mm	
198012	90	25	1
198008	120	30	1
198009	140	35	1
198010	160	40	1



DE	SCHILLERLOCKENFORMEN SCHRÄG
GB	CREAM HORN MOULDS OBLIQUE
IT	CORNETTI OBLIQUI
ES	MOLDES PARA CUCURUCHOS, OBLICUOS

Material: Edelstahl

made of stainless steel

#	↗ mm	Ø mm	
198013	120	30	1
198014	140	35	1
198015	160	40	1



9

DE	CANOLI
GB	CANOLI
IT	CANNOLI
ES	CANNOLLI

Material: Edelstahl

made of stainless steel

#	↗ mm	Ø mm	
198017	125	35	1



DE	RAHM- UND CREMEROLLEN
GB	CREAM ROLL MOULDS
IT	CANNOLI
ES	RODILLOS QUESO

Material: Edelstahl

made of stainless steel

#	↗ mm	Ø mm	
198000	200	9	1
198001	200	11	1
198002	200	12,5	1
198003	200	14	1
198004	200	16	1
198005	200	18	1
198006	140	22	1
198007	140	27	1



Art. 181014



DE	WASSER-SPRÜHPISTOLE
GB	WATER SPRAY GUN
IT	PISTOLA DA ACQUA
ES	PISTOLA PARA AGUA,

Teiglinge, Brote und Brötchen können waagrecht und nebelfrei besprüht werden
 raum- und zeitsparend
 hygienisch, ersetzt Brotstreicher
 Griff: PA, schwarz
 Schlauch ausziehbar bis 300 – 400 cm,
 Anschlüsse Edelstahl, Messing, vernickelt

for spraying steam on dough and bread.
 usable horizontally, space and time saving
 hygienic
 Handle: PA, black
 extensible hose up to 300 – 400 cm,
 connection made of stainless steel

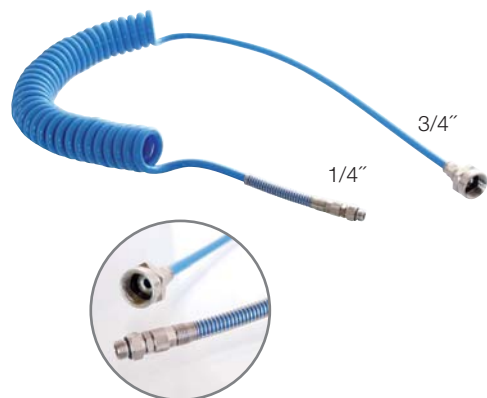

Art. 181100

Art. 181160

Art. 181170

#		📏 l (cm)	🛒
181014	Wasser-Sprühpistole gerade / spray gun, straight sprayer pipe	22	1
181100	Wasser-Sprühpistole 30° abgewinkelt / spray gun, angular sprayer pipe 30°	22	1
181160	Wasser-Sprühpistole 30° abgewinkelt / spray gun, angular sprayer pipe 30°	60	1
181170	Wasser-Sprühpistole 30° abgewinkelt / spray gun, angular sprayer pipe 30°	100	1
181200	Schlauch – blau / hose – blue		1



Art. 182005



DE	WASSER-SPRÜHPISTOLE	🍷🍴
GB	WATER SPRAY GUN	
IT	PISTOLA DA ACQUA	
ES	PISTOLA PARA AGUA,	

Teiglinge, Brote und Brötchen können waagrecht und nebelfrei besprüht werden
 raum- und zeitsparend
 hygienisch, ersetzt Brotstreicher
 Griff: PA, schwarz
 Schlauch ausziehbar bis 300 – 400 cm,
 alle Bauteile aus Edelstahl,
100% Lebensmittelecht

for spraying steam on dough and bread.
 usable horizontally, space and time saving
 hygienic
 Handle: PA, black
 extensible hose up to 300 – 400 cm,
 all components made of stainless steel.
100% food safe

Art. 182000



#		🛒
182005	Wasser-Sprühpistole gerade / spray gun, straight sprayer pipe	1
182000	Wasser-Sprühpistole 30° abgewinkelt / spray gun, angular sprayer pipe 30°	1
182010	Schlauch – schwarz / hose – black	1
182020	Ersatzteil-Set / Spare parts set	1
182030	Reduzierstück / adapter	1



Art. 182010



Art. 182020



Art. 182030



DE	HANDENTSTEINER
GB	PLUM STONING DEVICE
IT	SNOCCIOLATORE, PRUGNA
ES	QUITA PEPA HUESO DE CIRUELA

für Pflaumen und Zwetschgen,
mit Rechts- und Linkshandgriff,
obstsäurebeständiges Messer
Material: Aluminiumguss

for plums, usable for right and left-handed
users, with stone outlet and fruit ejector,
acid resistant knife
made of cast aluminum

#			
151300	Handentsteiner inkl. 6-teiliges Messer mit Auswerfer	1	
151301	Ersatzmesser 6-teilig/replacement knife (6 pcs.)	1	



9



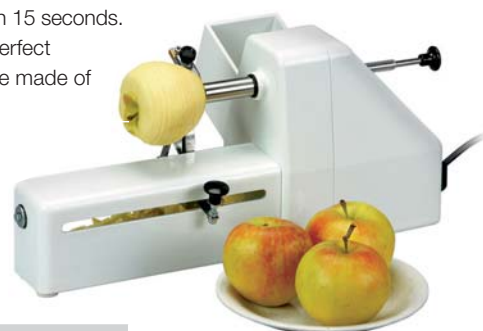

DE	APFELSCHÄL- UND TEILMASCHINE
GB	APPLE PEELING AND SLICING MACHINE
IT	PELA MELE, PICCOLO
ES	PELADORA CORTADORA DE MANZANAS, PEQUENA

Für Bäckereien, Konditoreien, Küchen,
gewerbliche Zwecke.
Maschine schält, entkernt und schneidet den
frischen Apfel innerhalb von 15 Sekunden in
Scheiben und sticht das Kernhaus aus.
Gehäuse aus Aluminiumguß, weiß lackiert.
Alle Metallteile aus rostfreiem Stahl.
Durch sämtliche Schutzvorrichtungen ist die
Sicherheit entsprechend den CE-Richtlinien
gewährleistet.

Peeling, coring and slicing within 15 seconds.
Cast aluminum case ensures perfect
stability, all mechanical parts are made of
stainless steel.
Approved by EC-regulations.



CE

#					
150000	60 W	220 V	130 x 410 x 195	5,6 kg	1

Dosiermaschinen / Gebäckfüller
 Dosingmeter / Cream Injector
 Dosatrice / Dosatrice per creme
 Inyectora-dosificadora / Inyector dosificador



**Das Edhard-System beinhaltet 3 Hauptkomponenten:
 Motorblock, Trichter und Pumpeneinheit und Dosiertülle.**

Edhard Dosiermaschine / Gebäckfüller zum automatischen Befüllen, Dosieren und Dekorieren von Gebäck und Lebensmitteln aller Art wie z.B. Teig, Butter, Käsekuchen, Hüttenkäse, Frischkäse, Sahne, Cremes, Früchtaufüllungen, Honig, Glasuren, Gelee, Ketchup, Sirup, Senf, Pudding, Püree, Salat-Dressing, Joghurt und viele andere Produkte.

VIDEO

www.schneider-gmbh.com

<http://www.schneider-gmbh.com/de/videos.html>

**This equipment consists of three main components:
 Power base, filler unit (pump and hopper) and the spouts.**

Automatic dosingmeter for injecting, depositing, layering and topping. A partial list of food products using the dosing systems: Dough, butter, cheesecake, cottage cheese, cream cheese, creams, custard, fruit fillings, honey, icing, jelly, ketchup, molasses, mustard, pudding, purees, salad dressing, yogurt and many other products.

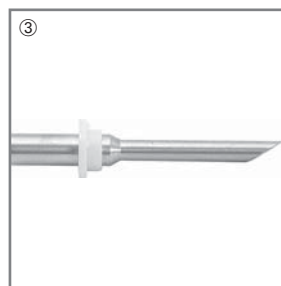

edhard





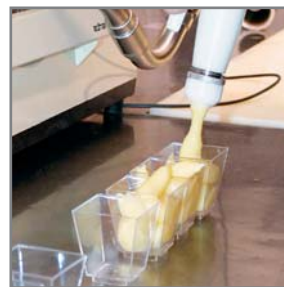

10



DE	DOSIERMASCHINE "EDHARD"
GB	DOSINGMETER "EDHARD"
IT	DOSATRICE "EDHARD"
ES	INYECTORA-DOSIFICADORA "EDHARD"

zum automatischen Füllen von Croissants, Donuts und Gebäckstücken jeder Art
 - sehr leicht zu bedienen, leicht zu reinigen
 - Dosiermenge über digitales Bedienfeld einstellbar
 - kein Tropfen, da gegenläufiger Arbeitsablauf

for stuffing croissant, donuts and all kinds of pastries
 - very simple to use, easy to clean
 - quantity to be dispensed is adjustable with a digital entry keypad from 0 to 99
 - no dripping because of reverse motion at end of fill cycle

#	152600	152840	152609	152845
	44 Watt	93 Watt	186 Watt	186 Watt
	Automatischer Zyklus / automatic cycle	Automatischer Zyklus / automatic cycle	Motor mit einstellbarer Geschwindigkeit, Geschwindigkeitskontrolle, Rücklauf und automatischem Zyklus / power base with variable speed, speed control, reverse and automatic cycle	Motor mit einstellbarer Geschwindigkeit, Geschwindigkeitskontrolle, Rücklauf und automatischem Zyklus / power base with variable speed, speed control, reverse and automatic cycle
↔ mm	172 x 391 x 229	241 x 391 x 229	241 x 391 x 229	300 x 400 x 225
	Motor / power base	Motor / power base	Motor / power base	Motor / power base
	220 Volt	240 Volt	240 Volt	240 Volt
 kg	5,5 kg	8,0 kg	8,0 kg	13,3 kg
	1	1	1	1



DE	TRICHTER
GB	FILLER UNITS
IT	TRAMOGGIA
ES	TOLVA-DEPOSITO



#		Ø mm	↑ mm	🗲 l	📊 kg	🛒
152610	einfach / single	229	381	5,5	1,70	1
152612	einfach / single	260	502	17,0	2,32	1
152611	doppelt / double	229	381	5,5	1,70	1
152613	doppelt / double	260	502	17,0	2,32 kg	1

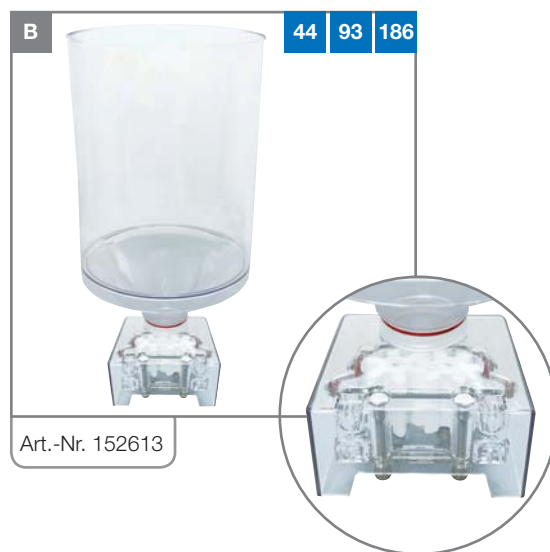
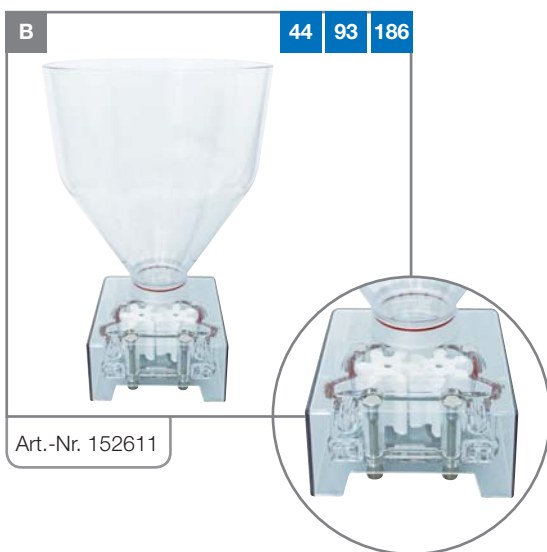

10



93 186

DE	TRICHTER EINFACH
GB	HOPPERS SINGLE
IT	TRAMOGGIA 1 USCITA
ES	TOLVA-DEPOSITO DE UNA SALIDA

#		für / for #	l	kg	
152860	einfach / single	152850, 152851	5,5	0,6	1
152861	einfach / single	152850, 152851	17,0	1,5	1



93 186

Material: Edelstahl made of stainless steel

#		für / for #	l	kg	
152862	Einfach / single	152850, 152851	17,0	4,3	1
152865	Einfach / single	152850, 152851	32,0	5,3	1



93 186

DE	PUMPEINHEIT AUS EDELSTAHL FÜR FLÜSSIGE PRODUKTE
GB	PUMP MADE OF STAINLESS STEEL FOR SMOOTH PRODUCTS
IT	GRUPPO POMPA IN ACCIAIO INOX PER PRODOTTI LIQUIDI
ES	BASE DE LA MAQUINA MOTOR EN ACERO INOXIDABLE PARA PRODUCTOS SUAVES

#		kg	
152850	Pumpeinheit einfach / pump single	3,8	1



93 186

DE	PUMPEINHEIT AUS EDELSTAHL FÜR FLÜSSIGE PRODUKTE
GB	PUMP MADE OF STAINLESS STEEL FOR SMOOTH PRODUCTS
IT	GRUPPO POMPA IN ACCIAIO INOX PER PRODOTTI LIQUIDI
ES	BASE DE LA MAQUINA MOTOR EN ACERO INOXIDABLE PARA PRODUCTOS SUAVES

#		kg	
152856	Pumpeinheit doppelt / pump double	4,2	1

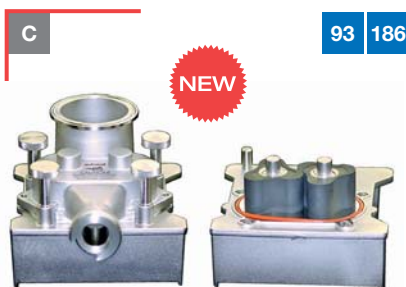

93 186

DE	PUMPEINHEIT AUS EDELSTAHL FÜR PRODUKTE MIT TEILCHEN
GB	PUMP MADE OF STAINLESS STEEL FOR PRODUCTS WITH PARTICLES
IT	GRUPPO POMPA IN ACCIAIO INOX PER PRODOTTI CON PEZZETTINI
ES	BASE DE LA MAQUINA MOTOR EN ACERO INOXIDABLE PARA PRODUCTOS CON PARTÍCULAS

für Teilchen max. 10 mm for particles max. 10 mm cube

#		kg	
152851	Pumpeinheit einfach / pump single	4,0	1

DE	KUPPLUNGSSTÜCK FÜR TRICHTER EINFACH
GB	ADAPTER FOR SINGLE FILLER UNITS
IT	ADATTATORE
ES	ADAPTADOR

▶ A

zur Verwendung von „2-fach“ Tüllen bei einfachen Trichtern for using “double spouts” for single filler units

#		für / for #	
152699	Kupplungsstück / adapter	151610, 151612, 152850, 152851	1



DE	TÜLLEN-ADAPTER
GB	EXTERNAL PIPING TUBE ADAPTER
IT	ADATTATORE PER BOCCHETTE
ES	ADAPTADOR PARA BOQUILLAS

Für Verlängerungsschlauch Art.-Nr. 152677 for hose assembly code 152677

#	Ø mm	
152710	24	1
152711	30	1
152712	35	1



10

DE	ZUBEHÖR FÜR DOSIERMASCHINE “EDHARD”
GB	ACCESSORIES FOR DOSINGMETER “EDHARD”
IT	ACCESSORI “EDHARD”
ES	ACCESORIOS “EDHARD”

#		
152679	Fußpedal / switch foot	1



DE	DONUT-FÜLLER
GB	DONUT-SPOUT
IT	TUBO DONUT
ES	CAÑO DONUT



















▶ A ▶ C

Material: Edelstahl, für 1-teilige Trichter made of stainless steel, for single filler units

#	Ø mm	↑ mm	
152880	88	30	1



DE	ZUBEHÖR FÜR DOSIERMASCHINE "EDHARD" PASSEND FÜR TRICHTER 152611, 152613, 152856
GB	ACCESSORIES FOR DOSINGMETER "EDHARD" USABLE FOR FILLER UNITS 152611, 152613, 152856
IT	ACCESSORI "EDHARD" 152611, 152613, 152856
ES	ACCESORIOS "EDHARD" 152611, 152613, 152856

#		Ø mm	↗ mm		
					
152630	Tülle, doppelt / spout double	11,1	89	1	
					
152631	Konfitüre-Tülle, doppelt / jam spout, double	11	82,5	1	
					
152632	Tülle glatt, doppelt / spout plain, double	4,8	41	1	
					
152652	Tülle geschlitzt, doppelt / spout éclair-slit, double	11,1	127	1	
					
152653	Tülle, doppelt / spout, double	11,1	127	1	
					
152657	Tülle glatt, doppelt / spout plain, double	7,9	111,1	1	
					
152659	Tülle geschlitzt, doppelt / spout éclair-slit, double	7,9	111,2	1	
					
152661	Tülle glatt 30° doppelt / spout plain 30° double	7,1	57	1	
					
152666	Berlinertülle, doppelt / spout "Krapfen", double	6,4	41,3	1	

DE	ZUBEHÖR FÜR DOSIERMASCHINE "EDHARD" PASSEND FÜR TRICHTER 152610, 152612, 152850, 152851
GB	ACCESSORIES FOR DOSINGMETER "EDHARD" USABLE FOR FILLER UNITS 152610, 152612, 152850, 152851
IT	ACCESSORI "EDHARD" 152610, 152612, 152850, 152851
ES	ACCESORIOS "EDHARD" 152610, 152612, 152850, 152851

#		Ø mm	↗ mm	→ mm	
---	--	------	------	------	---



					
152633	Tülle glatt, einfach / spout plain, single	22,2	57		1

					
152635	Tülle glatt, einfach / spout plain, single	22,2	89		1

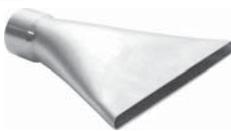
					
152636	Tülle glatt, einfach / spout plain, single	22,2	127		1

					
152638	Bandtülle / layering spout		101	7,1	1
152639	Bandtülle / layering spout		89	4,8	1
152640	Bandtülle / layering spout		40	4	1
152641	Bandtülle / layering spout		40	2	1
152642	Bandtülle / layering spout		60	3	1
152643	Bandtülle / layering spout		50	2,5	1
152644	Bandtülle / layering spout		70	3	1
152645	Bandtülle / layering spout		80	2,5	1
152646	Bandtülle / layering spout		30	3,6	1











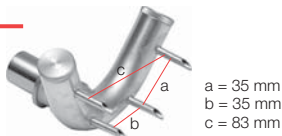

					
152647	Tülle einfach 45° / spout single 45°	22,2	120,6		1

					
152648	Dreifach-Tülle einfach / spout triple single	4,8 x 3	25	3	1

					
152654	Tülle glatt, einfach / spout plain, single	22,2	177,8	3	1

10

DE	ZUBEHÖR FÜR DOSIERMASCHINE "EDHARD" PASSEND FÜR TRICHTER 152610, 152612, 152850, 152851
GB	ACCESSORIES FOR DOSINGMETER "EDHARD" USABLE FOR FILLER UNITS 152610, 152612, 152850, 152851
IT	ACCESSORI "EDHARD" 152610, 152612, 152850, 152851
ES	ACCESORIOS "EDHARD" 152610, 152612, 152850, 152851

#		Ø mm	↗ mm	→ mm		
						
152655	Tülle geschlitzt, einfach / spout slit, single	22,2	111,2		1	
	 a = 35 mm b = 35 mm c = 83 mm					
152656	Croissant-Füller einfach / spout croissants, single	4,8 x 4	25	4	1	
						
152658	Tülle geschlitzt, einfach / spout slit, single	22,2	127		1	
						
152660	Tülle "Cannoli" einfach / spout "Cannoli" single	14,3	76,2		1	
						
152662	Tülle glatt, einfach / spout plain, single	22,2	41		1	
						
152663	Tülle Blaubeeren, einfach / spout blueberry, single	22,2	82,5		1	
						
152664	Tülle glatt, einfach / spout plain, single	22,2	111,2		1	
						
152665	univers. Verläng., einf. / univers. extensions, single	22,2	158,7		1	
						
152677	Verlängerung (Schlauch) / hose assembly	22,2	914		1	

DE	ZUBEHÖR FÜR DOSIERMASCHINE "EDHARD"
GB	ACCESSORIES FOR DOSINGMETER "EDHARD"
IT	ACCESSORI "EDHARD"
ES	ACCESORIOS "EDHARD"

#		für / for #	Ø mm		
---	--	-------------	------	---	--



152637	Ansatzstück für Art-Nr. / double spout for code	Art. 152665	19	1	
--------	---	-------------	----	---	--



152667	Anti-Tropfröhre für Art-Nr. / dripless valve for code	Art. 152649, 152650, 152651		1	
--------	---	-----------------------------	--	---	--



152668	Anti-Tropfröhre für Art-Nr. / dripless valve for code	Art. 152649, 152650, 152651		1	
--------	---	-----------------------------	--	---	--



152669	Anti-Tropfröhre für Art-Nr. / dripless valve for code	Art. 152665, 152677		1	
--------	---	---------------------	--	---	--



152670	Anti-Tropfröhre für Art-Nr. / dripless valve for code	Art. 152665, 152677		1	
--------	---	---------------------	--	---	--



152671	Dekortülle für Art-Nr. / decor tube for code	Art. 152665, 152677	9,7	1	
152672	Dekortülle für Art-Nr. / decor tube for code	Art. 152665, 152677	14	1	



152673	Dekortülle für Art-Nr. / decor tube for code	Art. 152665, 152677	14,2	1	
152674	Dekortülle für Art-Nr. / decor tube for code	Art. 152665, 152677	4,8 x 9,7	1	
152675	Dekortülle für Art-Nr. / decor tube for code	Art. 152665, 152677	12	1	
152676	Dekortülle für Art-Nr. / decor tube for code	Art. 152665, 152677	9,7	1	

10



Art. 151230

DE	GEBÄCKFÜLLER
GB	CREAM INJECTOR
IT	DOSATRICE PER CREME
ES	INYECTOR DOSIFICADOR

Füllkolben aus Edelstahl
 Dosiermenge regulierbar: 0 – 15 gr.
 Jedes Bauteil ist einfach zu reinigen.
 Inklusive 2 Deckel.

pistons made of stainless steel
 dosing adjustable: 0 – 15 gr.
 All components are easy to clean.
 Including 2 lids.

#		↔ mm	⚖ kg	📦 l	🛒
151200	2 Füllkolben/ 2 pistons	260 x 380 x 350	2,1	5,0	1
151230	1 Füllkolben/ 1 piston	260 x 380 x 350	2,0	5,0	1
151235	mit Donut- Füllkolben	260 x 380 x 350	2,0	5,0	1



Art. 151200



Art. 151235



Ø (mm)	80
Ø Nadel / needle (mm)	2
Höhe Nadel / Height needle (mm)	15
Abstand Nadel / Distance needle (mm)	20
Anzahl / quantity	8

DE	GEBÄCKFÜLLER
GB	CREAM INJECTOR
IT	DOSATRICE PER CREME
ES	INYECTOR DOSIFICADOR

Zum Füllen von Krapfen, Pfannkuchen und anderen Patisserie-Produkten mit max. Geschwindigkeit und Genauigkeit. Gehäuse aus Aluminiumguß. Trichter, Zylinder, Dosierer, Welle, Hebel und Auslaufrohr aus rostfreiem Edelstahl.

For filling "Krapfen", pancakes and other sweets with maximum speed and precision. Base made of cast aluminum. Funnel, cylinder, piston, injector, lever and thrust rib are made of stainless steel.

KLEIN

Technische Daten:

Auslaufrohr Ø: 24 mm
 Dosiermenge: 1 – 30 g
 Einfüllmenge: 2,0 l

SMALL

Technical specification:

piston Ø: 24 mm
 dosis: 1 – 30 g
 funnel: 2,0 l

#	↑ mm	→ mm	⚖ kg	🛒
153000	440	250	2,70	1

GROSS

Technische Daten:

Auslaufrohr Ø: 31 mm;
 Dosiermenge: 1 – 60 g
 Einfüllmenge: 5,2 l

LARGE

Technical specification:

piston Ø: 31 mm
 dosis: 1 – 60 g
 funnel: 5,2 l

#	↑ mm	→ mm	⚖ kg	🛒
153001	520	370	7,20	1



10

DE	GEBÄCKSPRITZE
GB	BISCUIT PASTRY-SYRINGE
IT	SIRINGA PER PASTICCERIA
ES	CHURRERA-MANGA MANUAL DE MANIVELA

Korpus, Gebäckspitze, Griff und Füße aus Aluminium
 Inklusive 13 Scheiben für unterschiedliche Spritzgebäckarten.

Body, fittings, pastry presses, handle and bracket made of aluminum.
 Including 13 different pastry presses for various shapes of biscuit pastry.

#	↔ mm	⚖ kg	🛒
152700	500 x 200 x 190	5,0	1



Thermometer
Thermometers
Termometri
Termometro



DE	REFRAKTOMETER
GB	REFRACTOMETER
IT	RIFRATTOMETRI
ES	REFRACTÓMETRO

Hand-Refraktometer zur Messung des Brix-Wertes von Zucker, Glasur, Sorbets, Konfitüren, Eis und Gelees. Automatisches temperaturkompensiertes (20°C) Messergebnis, Spritzwassergeschützt. Inkl. Aufbewahrungsbox

Hand-held refractometer for measuring brix of sugar, icing, sorbets, jams, ice cream and jellies. Automatic temperature compensation, splash proof. Including storage box.



#			
161020	0 – 50 % Brix	1	
161030	0 – 90 % Brix	1	

DE	THERMOMETER
GB	THERMOMETER
IT	TERMOMETRO
ES	TERMOMETRO

Temperaturfühler 1,5 mm dünn, fühlt die Temperatur im Produkt und nicht in der Umgebung. Reaktionszeit ca. 2 – 4 Sekunden. Genauigkeit: 0,1 °C. 80 cm Kabel. Gehäuse mit eingebautem Magnet – haftet an allen ferromagnetischen Oberflächen. Kostenlose APP (IOS- und Android Gerät) via Bluetooth mit dem Thermometer verknüpfbar. Für professionelle Wareneingangskontrolle; Datum, Uhrzeit und eigenen Notizen können mit dem zugeordneten Foto gespeichert und versendet werden. 2 x AA Batterien

Temperature sensor 1.5mm thin, the temperature is measured inside the product and not in the environment. Reaction time approx. 2-4 seconds. Accuracy: 0.1 ° C. Cable length 80 cm. Housing with built-in magnet – adheres to all ferromagnetic surfaces. Free app (IOS and Android device) can be connected via Bluetooth with the thermometer. For professional incoming goods inspection; Date, time and own notes can be saved and sent with the assigned photo. 2 x AA batteries



#	°C		
160050	- 200 / + 400	1	

DE	INFRAROT-THERMOMETER
GB	INFRARED THERMOMETERS
IT	TERMOMETRO AD INFRAROSSI
ES	TERMOMETRO INFRARROJO

für berührungsloses Messen der Oberflächentemperatur, mit Laservisier, einfach zu bedienen, inklusive Batterie

for non-contact measuring of surface temperature, with laser-sighting, easy to use, battery included

großes beleuchtetes Display
Messdauer 0,5 Sekunden

large backlight display
measuring time 0,5 seconds

#	°C	↔ mm	
160014	-35 / +365	166 x 34 x 64	1

CE



Art. 160014

CE

beleuchtetes Display, Messdauer 1,0 Sekunden, inklusive Batterie und Tasche

backlight display, measuring time 1,0 seconds, battery and bag included

#	°C	↔ mm	
160019	-33 / +500	175 x 39 x 79	1



Art. 160019

CE

Infrarot-Thermometer mit Einsteckfühler.

- Zum Messen der Oberflächen- und Kerntemperatur
- Max.-Min.-Funktion
- Messbereich Einsteckfühler 40°C+230°C
- Genauigkeit +/- 2°C im Bereich -40°C+20°C, +/-1°C im Bereich +20°C+100°C, sonst +/-1%, Auflösung 0,1°C, D:S = 4:1
- inkl. Batterie

Infrared thermometer with plug-in sensor.

- For measuring the surface and core temperature
- Max. min. function
- Measuring range insertion sensor 40°C+230°C
- Accuracy +/- 2°C in the range -40°C+20°C, +/-1°C in the range +20°C+100°C, otherwise +/-1%, resolution 0.1°C, D:S = 4:1
- incl. battery

#	°C	↔ mm	
160051	-40 / +280	140 x 380 x 24	1

CE



NEW

DE	THERMOMETER
GB	THERMOMETERS
IT	TERMOMETRI
ES	TERMOMETRO

Edelstahl

made of stainless steel



#	°C	für / for	
160005	0 / +350	Fleisch / meat	1

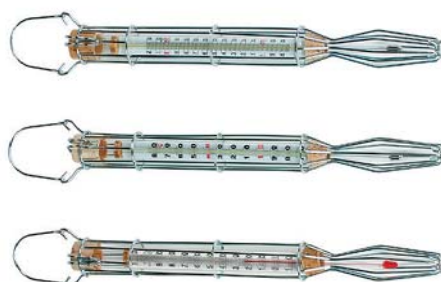

verchromter Draht

chromed wires

#	°C	für / for	↗ mm	
160001	-10 / +110	Milch / milk	300	1
160002	+80 / +180	Zucker / sugar	300	1
160003	+80 / +220	Fett / fat	300	1

Füllstoff: gefärbter Weingeist. / Filling material: colored alcohol.



Kunststoffgehäuse weiß

white plastic frame

#	°C	für / for	↗ mm	
160012	0 / +110	Milch / milk	360	1

Füllstoff: gefärbter Weingeist. / Filling material: colored alcohol.

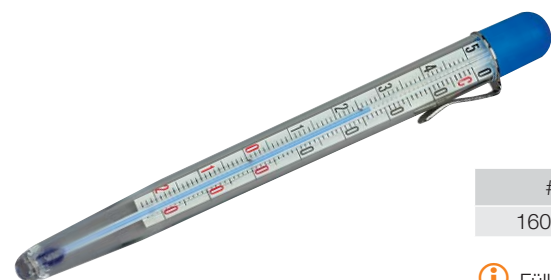

pen thermometers

#	°C	↗ mm	
160004	-20 / +50	140	1

Füllstoff: gefärbter Weingeist. / Filling material: colored alcohol.

DE	THERMOMETER	
GB	THERMOMETERS	
IT	TERMOMETRI	
ES	TERMOMETRO	

Kühlthermometer, Kunststoffgehäuse, mit Halter und Befestigungsmaterial
 Werksprüfschein liegt vor,
 Abweichung +/- 0,5 °C

Freezer-Fridge-Thermometer with plastic frame, support and fixing material
 Manufacturer test certificate available,
 Difference +/- 0,5 °C

#	°C	↗ mm	
160028	-30 / +20	265	1

 Füllstoff: gefärbter Weingeist. / Filling material: colored alcohol.



Kühlthermometer, Kunststoffgehäuse, drehbar

Freezer-Fridge-Thermometer with plastic frame, rotating

#	°C	↗ mm	
160026	-50 / +50	215 mm	1

 Füllstoff: gefärbter Weingeist. / Filling material: colored alcohol.



Kühlthermometer, Kunststoffgehäuse, mit Halter

Freezer-Fridge-Thermometer with plastic frame, and support

#	°C	↗ mm / Ø mm	
160034	-49 / +30	215	1
160035	-30 / +50	Ø: 52	1
160036	-50 / +50	Ø: 70	1



Art. 160035



Art. 160036



Art. 160034

DE	DIGITALER EINSTICHTHERMOMETER
GB	DIGITAL PROBE THERMOMETER
IT	TERMOMETRO CON SONDA
ES	TERMOMETRO CON SONDA

Für Temperaturmessungen in Flüssigkeiten, pulverigen und plastischen Stoffen.

For temperature measurements of liquid, powdered and plastic materials.

Mit extralangem Fühler (125 mm), wasserdicht, umschaltbar °C/°F
Inklusive Schutzhülse und Batterie.

With large sensor (125 mm), waterproof, switchable °C/°F
Including protection case and battery.

#	°C		
160006	- 40 / + 200		1



Temperaturmessung gemäß HACCP
Messung wahlweise berührungslos mit Infrarot oder mit Einstichfühler, wasserdicht inklusive Batterie

Temperature measurement acc. to HACCP measurement optionally contact free with infrared or with probe, waterproof battery included

#	°C	↔ mm	
160029	-40 / +250	60	1



Hold / Test-Funktion, Genauigkeit +/-1°C
Auflösung 0,1°C
Fühlerlänge: 140 mm
Inklusive Batterie

Hold / Test Function, Accuracy +/-1°C
Resolution 0,1°C
Probe length: 140 mm
battery included

#	°C	↔ mm	
160052	-50 / +300	240	1



DE	DIGITALER EINSTICHTHERMOMETER
GB	DIGITAL PROBE THERMOMETER
IT	TERMOMETRO CON SONDA
ES	TERMOMETRO CON SONDA

Hold / Test-Funktion	Hold / Test Function
Temperaturalarm	temperature alarm
Max.-Min.-Funktion	Max. min. function
Genauigkeit +/-1°C	Accuracy +/-1°C
Auflösung 0,1°C	Resolution 0,1°C
Fühlerlänge: 140 mm,	Probe length: 140 mm,
Kabellänge: ca.1 Meter, inkl. Batterie	Cable length: approx. 1 meter, incl. battery

#	°C	↔ mm		
160053	-50 / +300	140 x 95	1	



Temperaturalarm, Timer	temperature alarm, timer for setting and
Standgerät und mit Magnet	with magnet
Fühlerlänge: 140 mm,	Probe length: 140 mm,
Kabellänge: ca.1 Meter, inkl. Batterie	Cable length: approx. 1 meter, incl. battery

#	°C	↔ mm		
160054	0°C / +250	65 x 70	1	



11

DE	ELEKTRONISCHER TIMER
GB	ELECTRONIC TIMER
IT	TIMER PROGRAMMABILE ELETTRONICO
ES	TEMPORIZADOR ELECTRONICO

einfach zu bedienen, gut ablesbares Display, maximale Laufzeit 99 Min. und 59 Sek., Memory-Funktion, mit Magnet, inklusive Batterie, Gehäuse aus Edelstahl	easy to operate, well readable display, max.operating time: 99 min. and 59 sec. memory function, with magnet, battery included, case made of stainless steel
--	--

#	↔ mm		
160018	83 x 76 x 13	1	



Arbeitsschutz & Reinigung
 Protection & cleaning
 Protezione & Pulizia
 Protección & Limpieza



DE	BACKHANDSCHUHE "PREMIUM"
GB	BAKING MITTENS "PREMIUM"
IT	GUANTI DA FORNO "PREMIUM"
ES	GUANTES-MANOPLAS ANTICALORICAS "PREMIUM"

Spezial-Baumwollgewebe, Farbe natur,
 Innenhand und Daumen verstärkt
 hitzebeständig bis + 200 °C,
 waschmaschinenfest bis + 40 °C

special cotton fabric, natural colour, rein-
 forced palm and thumb
 heat resistant up to + 200 °C,
 machine-washable up to + 40 °C

#	↗ mm	→ mm	
<input checked="" type="checkbox"/> 310001	270	150	1



mit kurzen Stulpen

short cuffs

#	↗ mm	→ mm	
<input checked="" type="checkbox"/> 310002	340	160	1



mit langen Stulpen

long cuffs

#	↗ mm	→ mm	
<input checked="" type="checkbox"/> 310003	400	150	1



DE	BACKHANDSCHUHE
GB	BAKING MITTENS
IT	GUANTI DA FORNO
ES	GUANTES-MANOPLAS ANTICALORICAS

Spezial-Baumwollgewebe, Farbe natur, Innenhand und Daumen verstärkt hitzebeständig bis + 200 °C, waschmaschinenfest bis + 40 °C

special cotton fabric, natural colour, reinforced palm and thumb heat resistant up to + 200 °C, machine-washable up to + 40 °C



	#	↗ mm	→ mm	
☑	310083	300	150	1



Spezial-Baumwollgewebe, Farbe natur, Ganzflächig verstärkt, hitzebeständig bis + 200 °C, waschmaschinenfest bis + 40 °C

special cotton fabric, natural colour, fully reinforced, heat resistant up to + 200 °C, machine-washable up to + 40 °C



	#	↗ mm	→ mm	
☑	310019	325	150	1



Mit langen Stulpen, Spezial-Baumwollgewebe, Farbe natur, Innenhand und Daumen verstärkt hitzebeständig bis + 200 °C, waschmaschinenfest bis + 40 °C

Long cuffs, special cotton fabric, natural colour, reinforced palm and thumb heat resistant up to + 200 °C, machine-washable up to + 40 °C



	#	↗ mm	→ mm	
☑	310082	450	150	1



Leder-Backhandschuhe mit Baumwollstulpe, Farbe natur, Innenhand und Daumen verstärkt, hitzebeständig bis + 200 °C, nicht waschmaschinenfest

leather, special cotton fabric cuffs, natural colour, reinforced palm and thumb heat resistant up to + 200 °C, not machine-washable



	#	↗ mm	→ mm	
☑	310080	360	150	1



DE	BLECHANFASSER
GB	OVEN CLOTH
IT	PRESINA DA FORNO
ES	AGARRADOR PARA HORNO

Spezial-Baumwollgewebe gesäumt, Farbe natur, mit Griffflasche, hitzebeständig bis + 150 °C, waschmaschinenfest bis + 40 °C

special cotton fabric, reversible, natural colour, heat resistant up to + 150 °C, machine-washable up to + 40 °C



	#	↗ mm	→ mm	
	310004	290	240	1



DE	BACKHANDSCHUHE LEDER
GB	BAKING MITTENS LEATHER
IT	GUANTI DA FORNO IN PELLE
ES	GUANTES-MANOPLAS ANTICALORICAS EN CUERO



Leder, gefüttert,
hitzebeständig bis + 250 °C,
nicht waschmaschinenfest

leather, inner lining,
heat resistant up to + 250 °C,
not machine-washable

Leder mit Stulpen

leather with cuffs

#	↗ mm	→ mm	
<input checked="" type="checkbox"/> 310111	450	140	1



“5 Finger” mit Stulpen

“5 fingers” with cuffs

#	↗ mm	→ mm	
<input checked="" type="checkbox"/> 310023	450	140	1



“3 Finger” mit Stulpen, speziell für das Entnehmen von kleinen Blechen

“3 fingers” with cuffs, especially for taking small tins

#	↗ mm	→ mm	
<input checked="" type="checkbox"/> 310024	340	150	1



Leder mit Stulpen

leather with cuffs

#	↗ mm	→ mm	
<input checked="" type="checkbox"/> 310090	400	140	1



Leder mit Stulpen, gefüttert,
extrem hitzebeständig, bis + 450 °C,
Innenhand mit Kevlar – schnittfest

leather with cuffs, inner lining,
extremely heat resistant, up to + 450 °C,
inner part with KEVLAR – cut proof

#	↗ mm	→ mm	
310030	370	160	1



DE	BACKHANDSCHUHE SILIKON
GB	BAKING MITTENS SILICONE
IT	GUANTI DA FORNO IN SILICONE
ES	GUANTES ANTICALORICAS, SILICONA

100% Silikon, hitzebeständig bis + 300 °C, flexibles Material, wasserdicht, spülmaschinen-tauglich, hygienisch, sterilisierbar

100% silicone, heat resistant up to + 300 °C, flexible, waterproof, dishwasher proof, hygienic, can be sterilised

#	↗ mm	→ mm	🛒
310031	285	160	1
310032	385	180	1



DE	GASTROHANDSCHUH „SILIKON“
GB	GASTRO MITTENS „SILICONE“
IT	GUANTI GASTRO IN „SILICONE“
ES	GUANTES GASTRO „SILICONA“

Material: Silikon mit Baumwollfutter
 • Für Rechts- und Linkshänder
 • Zwischen Daumen und Zeigefinger verstärkt
 • Wasserdicht
 • Flexibles Material
 • Hitzebeständig bis + 250° C
 • Handreinigung max. 30 – 40°C

Made of silicone with cotton lining
 • For right- and left-handed
 • Reinforced between thumb and index finger
 • Waterproof
 • Flexible material
 • Heat resistant up to + 250° C
 • manual cleaning max. 30 – 40°C

#	↗ mm	→ mm	🛒
310099	380	150	1



DE	BACKHANDSCHUH NEOPREN
GB	BAKING MITTENS NEOPRENE
IT	GUANTI DA FORNO IN NEOPRENE
ES	GUANTES ANTICALORICAS NEOPRENO

Material: Neopren, schwarz
 • Für Rechts- und Linkshänder
 • Hitzebeständig bis + 260 °C
 • rutschfest
 • wasserabstoßendes und fleckenresistentes Material
 • Handreinigung max. 30 – 40°C

Made of neoprene, black
 • For right- and left-handed
 • Heat resistant up to + 260 °C
 • non-slip
 • Water repellent and stain resistant material
 • manual cleaning max. 30 – 40°C

#	↗ mm	→ mm	🛒
310085	350	145	1



12

DE	BAUMWOLLHANDSCHUHE "5 FINGER"
GB	BAKING MITTENS "5 FINGERS" – MADE OF COTTON
IT	GUANTI IN COTONE, BIANCHI
ES	GUANTES EN COTÓN BLANCOS

100% Baumwolle, weiß

pure cotton, white

#	↗ mm	→ mm	🛒
310027	240	100	1





DE	ZIP-HYGIENE-HANDSCHUH
GB	HYGIENE GLOVES
IT	GUANTI IGIENICI
ES	GUANTES HIGIENE

Dieser Handschuh bietet vollständige Keimfreiheit beim Umgang mit Lebensmitteln. Insbesondere in Bäckereien oder der Gastronomie ist dieses Produkt eine schnelle und unkomplizierte Hilfe ohne ständig die Hände reinigen zu müssen. Durch die Benutzung wird eine direkte Berührung mit dem Lebensmittel verhindert. Die Anwendung beim Ein- und Ausschlüpfen ist durch das Verbindungselement mit einem automatischen Auf- und Abwickeln einer Zugschnur einfach und praktisch!

These gloves offer complete sterility while food is being handled. Especially in bakeries or in the food service trade they are a fast and easygoing help. It is not necessary to permanently wash the hands. By using these gloves a direct food contact is being prevented. The application of removing and inserting the hands is made simple and practical thru the use of a connecting element which automatically reels – and unreels the pull cord connected to the gloves.

#	Größe / size		
391530	G-50		50
391550	G-50 / 1	mit 1 Clip / with 1 clip	50+1
391535		Ersatzclip / replacement clip	1

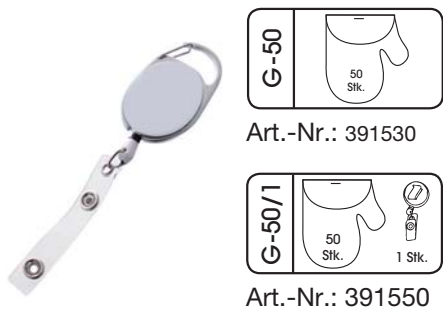

DE	EINWEGHANDSCHUHE
GB	GLOVES "ONE USE"
IT	GUANTI MONOUSO
ES	GUANTES DESECHABLES

Material: PE, transparent, geprägt, im Spenderkarton à 100 Stück

Made of PE, transparent embossed, in dispenser box à 100 pieces

#	↗ mm	
391510	280	100





Art. 120550 – 120552



Art. 120557

DE	ARBEITSSCHÜRZEN
GB	APRONS
IT	GREMBIULI
ES	DELANTALES

Material: spezialbeschichtetes Baumwollgewebe, reißfest und sehr stabil, gesäumt, hitzebeständig und einfach zu reinigen

made of specially coated cotton web, tear resistant, seamed, heat resistant, easy to clean

#	↔ mm		🛒	
120550	500 x 950		1	
120551	700 x 950		1	
120552	800 x 950		1	
120553	1000 x 950	mit Brustlatz / with bib	1	
120554	1100 x 950	mit Brustlatz / with bib	1	
120555	1200 x 1000	mit Brustlatz / with bib	1	
120556	1300 x 1000	mit Brustlatz / with bib	1	

Material: Baumwollgewebe, weiß, gesäumt

made of cotton, white, seamed

#	↔ mm	🛒	
120557	450 x 800	1	



Art. 120553 – 120556

12



DE	PAPIERMÜTZE "SCHIFFCHEN"
GB	LOW FORAGE HAT
IT	BUSTINA CARTA
ES	GORRO DE PAPEL FORMA "BARCA"

weiß, neutral, mit gelochtem Oberteil, verstellbar

white, non-printed, perforated top, adjustable

#	↑ mm	
120100	85	1000



DE	KOCHMÜTZE "STANDARD"
GB	PLEATED HAT "STANDARD"
IT	CAPPELLO DA CUOCO IN CARTA "STANDARD"
ES	GORRO DE PAPEL "STANDARD"

weiß, neutral, mit gelochtem Oberteil, verstellbar

white, non-printed, punctured top, adjustable

#	↑ mm	
120200	216	250

DE	KOCHMÜTZEN "PREMIUM"
GB	PLEATED HAT "PREMIUM"
IT	CAPPELLO DA CUOCO "PREMIUM"
ES	GORRO DE PAPEL "PREMIUM"

weiß, neutral, mit Schweißband, verstellbar white, non-printed, with sweatband, adjustable

#	↑ mm		
120450	209	250	



DE	KOCHMÜTZEN "MAITRE CHEF"
GB	PLEATED HAT "MAITRE CHEF"
IT	CAPPELLO DA CUOCO "MAITRE CHEF"
ES	GORRO DE PAPEL "MAITRE CHEF"

weiß, neutral, plissiert, mit Schweißband, verstellbar white, non-printed, pleated with sweatband, adjustable

#	↑ mm		
120400	249	250	



DE	HAUBEN "LADY"
GB	HAIR PROTECTION "LADY"
IT	CUFFIA "LADY"
ES	GORRO DE PAPEL SEÑORA "LADY"

aus leichtem Vliesstoff, weiß, bequem zu tragen made of soft and light nonwoven fabric, white, comfortable to wear

#		
120520	1000	



12

DE	BACKOFENBESEN
GB	OVEN BROOMS
IT	SCOPE DA FORNO
ES	ESCOBAS PARA HORNO











hitzebeständig bis + 300 °C, extra dicht besteckt, Naturfaser heat resistant up to + 300 °C, natural fabric besteckt, Naturfaser

#	↔ mm			
120650	500	Besen mit Metallschaber / broom with metal scraper	1	
120653	500	Besen / broom	1	
120651	1900	Stiel / stick	1	



Dekorieren
 Decoration
 Decorazioni
 Decorar



	MEHRWEG	MULTI USE
 	„MASTERFLEX“ <ul style="list-style-type: none"> • für höchste Ansprüche, 100% lebensmittelecht 	„MASTERFLEX“ <ul style="list-style-type: none"> • for top requirements, 100 % food-safe
 	„EXPORT“ <ul style="list-style-type: none"> • dickes Material • für den Konditor • mit Tüllenverstärkung • mit oberem Saum und Aufhänger 	„EXPORT“ <ul style="list-style-type: none"> • thick material • for the confectioner • with reinforced tip • with upper seam and hanger
 	„STANDARD“ <ul style="list-style-type: none"> • weiche Oberfläche • mit Tüllenverstärkung • mit oberem Saum und Aufhänger 	„STANDARD“ <ul style="list-style-type: none"> • soft surface • with reinforced tip • with upper seam and hanger
 	„NYLON SOFT“ <ul style="list-style-type: none"> • flexibel • leichtes "handling" • mit oberem Saum und Aufhänger 	„NYLON SOFT“ <ul style="list-style-type: none"> • flexible • easy handling • with upper seam and hanger
 	„PREMIUM“ <ul style="list-style-type: none"> • flexibel • Synthetik • mit oberem Saum und Aufhänger 	„PREMIUM“ <ul style="list-style-type: none"> • flexible • synthetic • with upper seam and hanger



	EINWEG	DISPOSABLE
	<ul style="list-style-type: none"> • blau-transparent • außen griffig • Spitze geschlossen • für alle Massen geeignet 	<ul style="list-style-type: none"> • blue-transparent • non-slip exterior • closed tip • for all fillings
	<ul style="list-style-type: none"> • grün-transparent • Spitze geschlossen • für alle Massen geeignet 	<ul style="list-style-type: none"> • green-transparent • closed tip • for all fillings
 	<ul style="list-style-type: none"> • nachhaltige Qualität • grün-transparent • Spitze geschlossen • für alle Massen geeignet 	<ul style="list-style-type: none"> • lasting quality • green-transparent • closed tip • for all fillings
 	<ul style="list-style-type: none"> • orange-transparent • außen extrem griffig • Spitze geschlossen • für alle Massen geeignet – (speziell für schwere und warme Massen) 	<ul style="list-style-type: none"> • orange-transparent • extreme non-slip exterior • closed tip • for all fillings
	<ul style="list-style-type: none"> • transparent • Spitze geschlossen • für alle Massen geeignet 	<ul style="list-style-type: none"> • transparent • closed tip • for all fillings
	<ul style="list-style-type: none"> • Doppelspritzbeutel mit Trenneinlage • transparent • Spitze geschlossen • für zwei verschiedene Massen geeignet 	<ul style="list-style-type: none"> • double-compartment pastry bag • transparent • closed tip • for two differnt fillings
	<ul style="list-style-type: none"> • “Zipper” zum Verschließen • transparent • mit Skala und Beschriftungsfeld • Spitze geschlossen • für alle Massen geeignet 	<ul style="list-style-type: none"> • “Zipper” to close • transparent • lettering field • closed tip • for all fillings



DE	SPRITZBEUTEL "MASTERFLEX"
GB	PASTRY BAGS "MASTERFLEX"
IT	SACCHETTO "MASTERFLEX"
ES	MANGA "MASTERFLEX"

Spezialmaterial für höchste Ansprüche
 100 % lebensmittelecht
 Längsnaht verschweißt
 mit Aufhänger
 Innenseite glatt
 Außenseite griffig
 flexibles Material
 undurchlässig
 auch für Mikrowelle geeignet

special material for highest requirements
 100 % food safe
 welded seam
 with hook
 inner surface smooth
 outer surface grippy
 flexible material
 impermeable
 suitable for microwave

#	Größe / size	↗ mm	
330002	2	340	10
330003	3	400	10
330004	4	460	10
330005	5	500	10
330007	7	600	10

DE	SPRITZBEUTEL "EXPORT"
GB	PASTRY BAGS "EXPORT"
IT	SACCHETTO "EXPORT"
ES	MANGA "EXPORT", CON DOBLADILLO

Baumwollgewebe mit starker Spezial-
beschichtung
lebensmittelecht
verschweißte Längsnaht
mehrmals verwendbar
undurchlässig

cotton fabric with strong special coating
food safe
welded seam
useable several times
impermeable

mit Saum und Tüllenverstärkung

with upper seam and reinforced tip

#	Größe / size	↗ mm	
350080	0	250	1
350081	1	280	1
350082	2	340	1
350083	3	400	1
350084	4	460	1
350085	5	500	1
350086	6	550	1
350087	7	600	1
350088	8	650	1
350089	9	700	1
350090	10	750	1



DE	SPRITZBEUTEL "STANDARD"
GB	PASTRY BAGS "STANDARD"
IT	SACCHETTO "STANDARD"
ES	MANGA "STANDARD", CON DOBLADILLO

Baumwollgewebe mit starker Spezial-
beschichtung
lebensmittelecht
verschweißte Längsnaht
mehrmals verwendbar
undurchlässig

cotton fabric with strong special coating
food safe
welded seam
useable several times
impermeable

mit Saum und Tüllenverstärkung

with upper seam and reinforced tip

#	Größe / size	↗ mm	
350170	0	250	1
350171	1	280	1
350172	2	340	1
350173	3	400	1
350174	4	460	1
350175	5	500	1
350176	6	550	1
350177	7	600	1
350178	8	650	1
350179	9	700	1
350180	10	750	1



DE	SPRITZBEUTEL "NYLON-SOFT"
GB	PASTRY BAGS "NYLON-SOFT"
IT	SACCHETTO "NYLON-SOFT"
ES	MANGA "NYLON-SOFT"

Nylongewebe, lebensmittelecht
 Längsnaht verschweißt mit Saum,
 Aufhänger und ohne verstärkte Spitze
 mehrmals verwendbar
 undurchlässig

nylon fabric, food safe
 welded seam, with upper seam and hanger
 without reinforced tip
 useable several times
 impermeable



#	Größe / size	↗ mm		
351400	0	250	1	
351401	1	280	1	
351402	2	340	1	
351403	3	400	1	
351404	4	460	1	
351405	5	500	1	
351406	6	550	1	
351407	7	600	1	
351408	8	650	1	
351409	9	700	1	
351410	10	750	1	

DE	SPRITZBEUTEL "PREMIUM"
GB	PASTRY BAG "PREMIUM"
IT	SACCHETTO "PREMIUM"
ES	MANGA "PREMIUM"

synthetisches Gewebe mit Spezial-
 beschichtung
 lebensmittelecht
 mit Aufhänger
 mehrmals verwendbar
 undurchlässig

synthetic fabric with special coating
 food safe
 including hanger
 useable several times
 impermeable



#	Größe / size	↗ mm		
350250	0	250	1	
350251	1	280	1	
350252	2	340	1	
350253	3	400	1	
350254	4	460	1	
350255	5	500	1	
350256	6	550	1	
350257	7	600	1	
350258	8	650	1	
350259	9	700	1	
350260	10	750	1	

DE	HAUSHALTS-SPRITZBEUTEL
GB	PASTRY BAGS FOR DOMESTIC USE
IT	SACCHETTO - USO CASALINGO
ES	MANGA PARA DECORAR - USO CASERO

Baumwollgewebe mit Spezialbeschichtung, lebensmittelecht, undurchlässig, mehrmals verwendbar, ohne Saum und ohne Aufhänger

cotton fabric with special coating, food safe, impermeable, useable several times, without seam and without hanger

Mit 2-teiligem Schraubadapter, 3 Sterntüllen, 1 Lochtülle, 1 Dekortülle und 1 Berlinertülle

with special adapter, 3 star tubes, 1 plain tube, 1 decoration tube and 1 fritter tube



#	Größe / size	↗ mm	
<input checked="" type="checkbox"/> 350144	1	280	1
<input checked="" type="checkbox"/> 350145	1a	310	1

DE	DEKOR-SPRITZBEUTEL
GB	DECORATING BAG
IT	SACCHETTO PER DECORARE
ES	MANGA PARA DECORAR

beschichtetes Spezialgewebe
Längsnaht verklebt, ganz geschlossen
lebensmittelecht
undurchlässig
mehrmals verwendbar

cotton fabric with special coating
glued seam, with closed tip
food safe
impermeable
useable several times

#	↗ mm	
350650	210	1 Beutel = 5 Stk.



13

DE	DEKOR-SPRITZBEUTEL "PERGAMYN"
GB	DECORATING BAGS "PERGAMYN"
IT	SACCHETTI PER DECORARE "PERGAMINA"
ES	MANGAS PARA DECORAR "PERGAMYN"

Material: Pergamyn,
mit oder ohne Tülle verwendbar

made of pergamyn,
useable with or without tube

#	↗ mm	
350600	210	1000
350601	370	1000





DE	SPRITZBEUTEL-WANDAUFHÄNGER
GB	WALL RACKS FOR PASTRY BAGS
IT	ESPOSITORI PER SACCHETTI E BOCCHETTE
ES	SECADOR DE MANGAS Y BOQUILLAS, RECUBIERTO

sehr stabile Ausführung, verpackt im Einzelkarton, für 4 Spritzbeutel und 31 Tüllen maximal verwendbar, inkl. Kleingeräteablage und 5 Haken

sturdy, single packing, for 4 pastry bags and 31 piping tubes; with rack for depositing small tools, with 5 hooks

#		↔ mm	
157000	weiß beschichtet / coated in white plastic	500 x 500	1
157001	Edelstahl rostfrei / made of stainless steel	500 x 500	1



DE	SPRITZBEUTEL-ABSETZSTÄNDER
GB	SUPPORT FOR PASTRY BAGS
IT	VASO PORTA SACCHETTO
ES	SOPORTE PARA MANGAS

Material: PP, Farbe elfenbein, stabil mit 8 Aussparungen für 4 große und 4 kleine Spritztüllen

made of PP, ivory, stable with holes for 4 large and 4 small tubes

#	↓ Ø mm	↑ mm	
157002	195	230	1

DE	EINWEG-SPRITZBEUTEL-SET
GB	SET OF DISPOSABLE PASTRY BAGS
IT	SET SACCHETTI USA E GETTA
ES	JUEGO DE MANGAS DESECHABLES

Set bestehend aus 10 Einweg-Spritzbeuteln (Länge 340 mm), 1 Lochtülle, 1 Sternbandtülle, 2 Sternfüllen, 1 Verschlussfülle und 1 Verschlussclip 10 cm mit Schneidmesser

set of 10 disposable bags (length 340 mm), 1 plain tube, 1 star ribbon tube, 2 star tubes, 1 tube fastener, 1 clip 10 cm length with integrated knife, pastry bags made of PE, tubes and clip made of PP

#			
350199		1 Set	



DE	EINWEG-SPRITZBEUTEL - DOPPELT
GB	DISPOSABLE PASTRY BAGS - DOUBLE
IT	SACCHETTI USA E GETTA - DOPPIO
ES	MANGAS DESECHABLES EN PAQUETE - DOBLE

Doppelspritzbeutel mit Trenneinlage für zwei verschiedene Massen.

Material: PE, **doppelt extrudiert**. Innenseite glatt, gebündelt, transparent, hygienisch, Spitze geschlossen, ohne Tülle verwendbar, hohe Reißfestigkeit der Schweißnaht; Karton mit Dispenseröffnung

Double-Compartmented pastry bag with a partition down in the middle, best for using two different ingredients.

Made of PE, **multiple layers**, silky inner surface for maximum product flow, bundle, transparent, hygienic, closed tip, can be used without tube for decorating purposes, seam with high tensile strength; box dispenser

#	↗ mm	→ mm	⊥ mm (μ)		
391850	455	305	70	75/Box	



DE	EINWEG-SPRITZBEUTEL - "ZIPPER"
GB	DISPOSABLE PASTRY BAGS - "ZIPPER"
IT	SACCHETTI USA E GETTA - "ZIPPER"
ES	MANGAS DESECHABLES - "ZIPPER"

Material: CPP, hochtransparent, mit Skala, Beschriftungsfeld und Zipper zum Verschließen

Made of CPP, crystal clear, graduated, lettering field and zipper to close

#	↗ mm	→ mm	⊥ mm (μ)		
391050	320	150	50	50/Box	

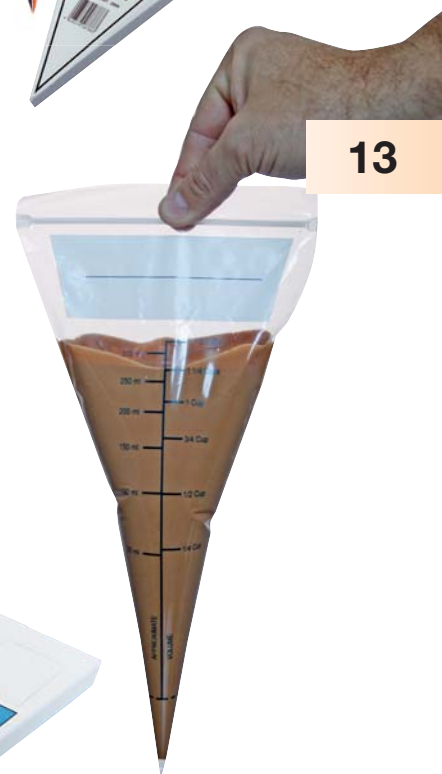

DE	EINWEG-SPRITZBEUTEL - GEBÜNDELT
GB	DISPOSABLE PASTRY BAGS - BUNDLES
IT	SACCHETTI USA E GETTA IN PAQUETTO
ES	MANGAS DESECHABLES EN PAQUETE

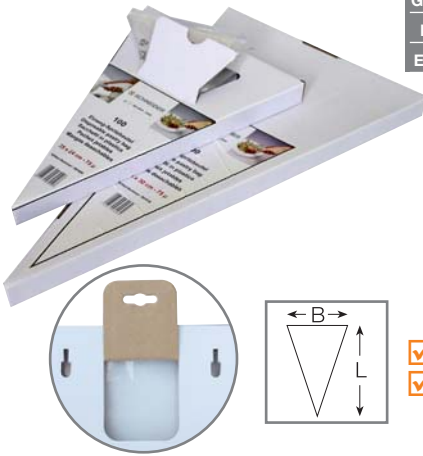

Material: PE, **doppelt extrudiert**, Innenseite glatt, mit Abreißperforation, transparent, hygienisch, Spitze geschlossen, mit oder ohne Tülle verwendbar, hohe Reißfestigkeit der Schweißnaht; Karton mit Dispenseröffnung

made of PE, **multiple layers**, silky inner surface for maximum product flow, safe perforation, transparent, hygienic, closed tip, can be used with or without tube for decorating purposes, seam with high tensile strength; box dispenser

#	↗ mm	→ mm	⊥ mm (μ)		
<input checked="" type="checkbox"/> 391400	350	240	75	100	
<input checked="" type="checkbox"/> 391410	545	300	75	100	



DE	EINWEG-SPRITZBEUTEL - GEROLLT
GB	DISPOSABLE PASTRY BAGS - ON ROLLS
IT	SACCHETTI USA E GETTA IN ROTOLI
ES	MANGAS DESECHABLES EN ROLLO

Material: PE, **dreifach extrudiert**, Außenseite sehr griffig, Innenseite glatt, mit Abreißperforation, blau-transparent, hygienisch, Spitze geschlossen, mit oder ohne Tülle verwendbar, hohe Reißfestigkeit der Schweißnaht; Karton mit Entnahmeöffnung

made of PE, **3-layers**, non-slip exterior, silky inner surface for maximum product flow, blue-transparent, fast & safe perforation tear-off, hygienic, closed tip, can be used with or without tube for decorating purposes, seam with high tensile strength; Box with convenient dispenser

#	↗ mm	→ mm	⊥ mm (μ)		
391200	350	195	75	100/Box	
391210	470	230	75	100/Box	
391220	530	275	75	100/Box	
391230	600	300	75	100/Box	
391240	300	160	75	100/Box	



DE	EINWEG-SPRITZBEUTEL „ECO“ - GEROLLT
GB	DISPOSABLE PASTRY BAGS „ECO“ - ON ROLLS
IT	SACCHETTI „ECO“
ES	MANGAS DESECHABLES EN ROLLO „ECO“

Material: PE, **doppelt extrudiert**, Innenseite glatt, mit Abreißperforation, grün-transparent, hygienisch, Spitze geschlossen, mit oder ohne Tülle verwendbar, hohe Reißfestigkeit der Schweißnaht; Karton mit Entnahmeöffnung

made of PE, **multiple layers**, silky inner surface for maximum product flow, green-transparent, fast & safe perforation tear-off, hygienic, closed tip, can be used with or without tube for decorating purposes, seam with high tensile strength; Box with convenient dispenser

#	↗ mm	→ mm	⊥ mm (μ)		
391800	350	195	70	100/Box	
391810	470	230	70	100/Box	
391820	530	275	70	100/Box	

DE	EINWEGSPRITZBEUTEL – GEROLLT „EFFICIENCY“
GB	DISPOSABLE PASTRY BAGS – ON ROLLS “EFFICIENCY”
IT	SACCHETTI USA E GETTA IN ROTOLI “EFFICIENCY”
ES	MANGAS DESECHABLES EN ROLLO “EFFICIENCY”

Material: PE, **mehrfach extrudiert**, Innenseite glatt, mit Abreißperforation, grün-transparent, hygienisch, Spitze geschlossen, mit oder ohne Tülle verwendbar, hohe Reißfestigkeit der Schweißnaht; Karton mit Entnahmeöffnung

Spezielle Rezepturen und mehrschichtige Folienextrusionen ermöglichen die Produktion bei stark reduzierter Materialstärke, bei gleichzeitig hoher Festigkeit und sogar verbesserten Eigenschaften wie Öl- und Temperaturbeständigkeit.

Wir tragen dazu bei, die lebenslangen Umweltauswirkungen zu reduzieren, indem weniger Ressourcen verbraucht werden und weniger CO₂-Treibhausgasemissionen bei Produktion, Versand, Recycling / Entsorgung entstehen.

made of PE, **multiple layers**, silky inner surface for maximum product flow, green-transparent, fast & safe perforation tear-off, hygienic, closed tip, can be used with or without tube for decorating purposes, seam with high tensile strength; Box with convenient dispenser

Special formulas and multiple layered film extrusions enable production at greatly reduced gauges, whilst insuring high strength and even enhanced features such as oil and increased temperature resistance. We thereby help to reduce the lifetime environmental impacts of its products by using less non-renewable resources and creating less CO₂ greenhouse gas emissions in the production, shipping, recycling/waste disposal process, less wastage and less pollution.

#	↗ mm	→ mm	⏏ mm (μ)	🛒
391880	530	275	60	100/Box

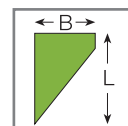

 Material Efficiency^{©2018}
For a greener World

DE	EINWEG-SPRITZBEUTEL - GEROLLT “ORANGE”
GB	DISPOSABLE PASTRY BAGS - ON ROLLS “ORANGE”
IT	SACCHETTI USA E GETTA IN ROTOLI “ARANCIONE”
ES	MANGAS DESECHABLES EN ROLLO “COLOR NARANJA”

Material: PE, **vierfach extrudiert**, für alle Massen (warm, kalt, fest) geeignet. Extrem griffig, auch mit nassen oder fettigen Händen einsetzbar. Innenseite glatt, mit Abreißperforation. Hygienisch, Spitze geschlossen, mit oder ohne Tülle verwendbar, hohe Reißfestigkeit der Schweißnaht. Karton mit Entnahmeöffnung.
– mikrowellentauglich

Material: PE, **4-layers**, suitable for all kinds of masses (hot, cold, solid). Extremely grippy, also usable with wet or greasy hands, silky inner surface for maximum product flow, with tear perforation. Hygienic, tip closed, can be used with or without tube, seam with high tensile strength. Box with convenient dispenser.
– microwave-safe

#	↗ mm	→ mm	⏏ mm (μ)	🛒
391320	530	280	80	100/Box
391330	590	280	80	100/Box

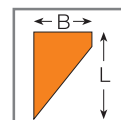

13



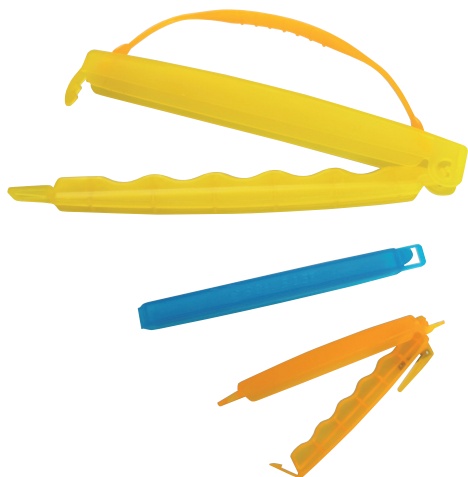

DE	VERSCHLUSS-CLIP
GB	FASTENING CLIPS
IT	CLIP DI CHIUSURA
ES	CLIPS DE PLASTICO

Material: PP
Zum dichten Verschließen von Spritzbeuteln und Vorratsbeuteln, spülmaschinenfest

Made of PP
For closing of pastry bags and other bags, dishwasher proof

	#	↗ mm		
<input checked="" type="checkbox"/>	391900	125	mit Messer / including knife	6
<input checked="" type="checkbox"/>	391901	175	ohne Messer / without knife	6
<input checked="" type="checkbox"/>	391902	285	mit abnehmbarem Griff / with twist-on handle	4

DE	TORTEN- UND DEKORIERPLATTE, DREHBAR	
GB	TILTING TURNTABLE	
IT	ALZATA PER TORTA, GIREVOLE E ORIENTABILE	
ES	SOPORTE GIRATORIO RECLINABLE	

Melamin, Kunststoff, dreh- und schwenkbar, stabile Qualität inkl. Anti-Rutsch-Füßen, Anti-Rutsch-Oberfläche

made of melamine, plastic, turnable, tilting, sturdy, with anti slip feet and top slip

#	Ø mm	↑ mm	
227220	300	160	1



DE	BLUMENSTEMPEL-SET (3-TEILIG)
GB	SET OF 3 FLOWER NAILS
IT	SET 3 CHIODI PER FIORI
ES	JUEGO DE 3 CLAVOS PARA FLORES

Material: Edelstahl
Set bestehend aus je 1 Stück:
halbrund, halbrund-abgeflacht, flach

made of stainless steel
set consisting of 1 nail each:
round, oval, flat

#			
197350	1 Set / 1 set	1	



DE	TÜLLENBÜRSTE
GB	BRUSH FOR TUBES
IT	BRUSCHINO PER BOCCHETTE
ES	CEPILLO PARA LIMPIAR BOQUILLAS

für alle Tüllen verwendbar, Borsten aus Nylon, Griff aus PP, mit Aufhängeöse

useable for all tubes, bristles made of nylon, grip of polypropylene, with hole

#	↗ mm		
200245	180	1	



DE	TÜLLEN-ADAPTER
GB	EXTERNAL PIPING TUBE ADAPTER
IT	ADATTATORE PER BOCCHETTE
ES	ADAPTADOR PARA BOQUILLAS

Material: PP, weiss, 2-teilig;
Schraubverschluss

PP, white, 2 pieces;
Screw thread

#	↑ mm		
197595	77	1	



Bsp.: Für nahezu alle Tüllen verwendbar!
Can be used for nearly all nozzles!



13

DE	TÜLLEN-ADAPTER-SET
GB	EXTERNAL PIPING TUBE ADAPTER-SET
IT	SET DI ADATTATORI PER BOCCHETTE
ES	SURDITO ADAPTADOR PARA BOQUILLAS

Material: PP, weiß, 6-teilig, Schraubverschluss

made of PP, white, 6 pieces, screw thread

#			
350147	3 Sterntüllen / 3 star tubes 1 Lochtülle / 1 plain tubes 1 Dekortülle / 1 decoration tube 1 Berliner Tüller / 1 fritter tube	1 Set	





DE	STERNTÜLLEN
GB	STAR TUBES
IT	BOCCHETTE FORO STELLA, IN UNIPEZZO, INOX
ES	BOQUILLAS ESTRELLA, MONOBLOQUE

Material: Edelstahl, **aus einem Stück gezogen** made of stainless steel - **in one piece**



#	Ø mm	Zähne / teeth	
197550	2	6	25
197551	3	6	25
197552	4	6	25
197553	5	6	25
197554	6	6	25
197555	7	6	25
197556	8	6	25
197557	9	6	25
197558	10	7	25
197559	11	7	25
197560	12	7	25
197561	13	7	25
197562	14	8	25
197563	15	8	25
197564	16	9	25
197565	17	9	25
197566	18	10	25



DE	STERNTÜLLEN-SATZ
GB	SET OF STAR TUBES
IT	SET DI BOCCHETTE FORO STELLA, IN UNIPEZZO, INOX
ES	JUEGO DE BOQUILLAS ESTRELLA, MONOBLOQUE

Material: Edelstahl, **aus einem Stück gezogen** made of stainless steel - **in one piece**

#	Ø mm	
<input checked="" type="checkbox"/> 197136	Satz 10-teilig / set 10 pcs. 4, 5, 6, 7, 8, 9, 10, 12, 13, 15	1 Set



DE	LOCHTÜLLEN
GB	PLAIN TUBES
IT	BOCCHETTE FORO TONDO, IN UNIPEZZO, INOX
ES	BOQUILLAS LISAS, MONOBLOQUE

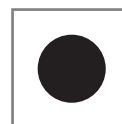

Material:Edelstahl,**auseinemStückgezogen** made of stainless steel - **in one piece**

#	Ø mm		
197500	2	25	
197501	3	25	
197502	4	25	
197503	5	25	
197504	6	25	
197505	7	25	
197506	8	25	
197507	9	25	
197508	10	25	
197509	11	25	
197510	12	25	
197511	13	25	
197512	14	25	
197513	15	25	
197514	16	25	
197515	17	25	
197516	18	25	
197517	20	25	
197518	22	25	
197519	24	25	



DE	LOCHTÜLLEN-SATZ
GB	SET OF PLAIN TUBES
IT	SET DI BOCCHETTE FORO TONDO, IN UNIPEZZO, INOX
ES	JUEGO DE BOQUILLAS LISAS, MONOBLOQUE



Material:Edelstahl,**auseinemStückgezogen** made of stainless steel - **in one piece**

#	Ø mm		
<input checked="" type="checkbox"/> 197180	Satz 10-teilig / set 10 pcs. 4, 5, 6, 7, 8, 9, 10, 12, 13, 15	1 Set	





DE	STERNTÜLLEN (FRANZÖSISCHE TÜLLEN)
GB	FRENCH STAR TUBES
IT	BOCCHETTE STELLA FRANCESE, IN UNIPEZZO, INOX
ES	BOQUILLAS ESTRELLA FRANCESA, MONOBLOQUE

Material: Edelstahl, **aus einem Stück gezogen** made of stainless steel - **in one piece**



#	Ø mm	Zähne / teeth	
197335	4	9	25
197310	5	9	25
197311	6	9	25
197312	7	10	25
197313	8	12	25
197336	9	12	25
197314	10	14	25
197333	11	14	25
197315	12	15	25
197316	13	15	25
197317	14	16	25
197337	15	15	25
197318	16	17	25
197319	18	18	25

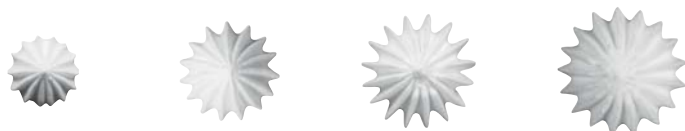

DE	STERNTÜLLEN, GESCHLOSSEN
GB	CLOSED STAR TUBES
IT	BOCCHETTE STELLA CHIUSA, IN UNIPEZZO, INOX
ES	BOQUILLAS ESTRELLA CERRADA, MONOBLOQUE

Material: Edelstahl, **aus einem Stück gezogen** made of stainless steel - **in one piece**



#	Ø mm	Zähne / teeth	
197320	2	6	25
197321	3	6	25
197322	4	6	25
197323	5	6	25
197324	6	6	25
197325	7	6	25
197326	8	7	25
197327	9	7	25
197328	10	8	25
197329	11	9	25
197334	12	10	25



DE	STERNBANDTÜLLEN
GB	STAR RIBBON TUBES
IT	BOCCHETTE DELIZIA, IN UNIPEZZO, INOX
ES	BOQUILLAS "CINTA ESTRIADA", MONOBLOQUE



Material: Edelstahl, **aus einem Stück gezogen** made of stainless steel - **in one piece**

#	Öffnungsgröße / opening size (mm)		
197300	16 x 2	25	
197301	20 x 3	25	
197302	28 x 4	25	



DE	ROSENTÜLLEN
GB	ROSE TUBES
IT	BOCCHETTE "ROSA", IN UNIPEZZO, INOX
ES	BOQUILLAS "ROSA", MONOBLOQUE



Material: Edelstahl, **aus einem Stück gezogen** made of stainless steel - **in one piece**

#	Ø mm		
197330	5	25	
197331	6	25	
197332	8	25	



13

DE	BERLINER TÜLLE
GB	FRITTER TUBE
IT	IMBUTINO (P.ES. PER BOMBOLONI), INOX
ES	BOQUILLAS ESPECIALES (P.E. PARA LLENAR CHURROS)



Material: Edelstahl, verschweißt made of stainless steel, welded seam

#	↑ mm	Ø mm		
197340	95	4	25	





DE	VERGISSMEINNICHT
GB	FORGET-ME-NOT
IT	NONTISCORDARDIMÉ
ES	NOMEOLVIDES

#	197400
Ø mm	4,5
↑ mm	39
	6



DE	ROSENAUSDREHER
GB	ROSE SCREW
IT	ROSA GIRATA
ES	ROSA RETORCIDA

#	197401
Ø mm	6,0
↑ mm	41
	6



DE	GESCHLOSSENES LOCH
GB	CLOSED PLAIN
IT	FORO TONDO CHIUSO
ES	LISA CERRADA

#	197402
Ø mm	5,0
↑ mm	48
	6



DE	BLÜTENBLATT KLEIN
GB	PETAL SMALL
IT	PETALO PICCOLO
ES	PÉTALO PEQUEÑO

#	197405
↔ mm	3,6 x 16
↑ mm	41
	6



DE	BLÜTENBLATT MITTEL
GB	PETAL MEDIUM
IT	PETALO MEDIO
ES	PÉTALO MEDIO

#	197406
↔ mm	5,4 x 25
↑ mm	44
	6



DE	BLÜTENBLATT GROSS
GB	PETAL LARGE
IT	PETALO GRANDE
ES	PÉTALO GRANDE

#	197407
↔ mm	3 x 15
↑ mm	53
	6



DE	BLATTTÜLLE MINI
GB	LEAF MINI
IT	FOGLIO MINI
ES	OJA MINI

#	197408
Ø mm	2,7
↑ mm	41
	6



DE	BLATTTÜLLE KLEIN
GB	LEAF SMALL
IT	FOGLIO PICCOLO
ES	OJA PEQUEÑA

#	197409
Ø mm	2,0
↑ mm	43
	6



DE	BLATTTÜLLE MITTEL
GB	LEAF MEDIUM
IT	FOGLIO MEDIO
ES	OJA MEDIA

#	197410
Ø mm	4,8
↑ mm	42
	6



DE	BLATTTÜLLE GROSS
GB	LEAF LARGE
IT	FOGLIO GRANDE
ES	OJA GRANDE

#	197411
Ø mm	4,6
↑ mm	52
	6



DE	GARNIERTÜLLE
GB	GARNISHING TUBE
IT	BOCCHETTA DECORATRICE
ES	BOQUILLA

#	197412
Ø mm	2,4
↑ mm	52
	6



DE	GARNIERTÜLLE
GB	GARNISHING TUBE
IT	BOCCHETTA DECORATRICE
ES	BOQUILLA

#	197413
Ø mm	6,0
↑ mm	47
	6



DE	GARNIERTÜLLE
GB	GARNISHING TUBE
IT	BOCCHETTA DECORATRICE
ES	BOQUILLA

#	197414
Ø mm	1,5
↑ mm	47
	6



DE	GARNIERTÜLLE
GB	GARNISHING TUBE
IT	BOCCHETTA DECORATRICE
ES	BOQUILLA

#	197415
Ø mm	6,0
↑ mm	52
	6



DE	GARNIERTÜLLE
GB	GARNISHING TUBE
IT	BOCCHETTA DECORATRICE
ES	BOQUILLA

#	197417
Ø mm	9,3
↑ mm	52
	6



DE	STERNBANDTÜLLE OFFEN
GB	STAR RIBBON TUBE OPEN
IT	BOCCHETTA DELIZIA APERTA
ES	BOQUILLA CINTA ESTRIADA ABIERTA

#	197418
↔ mm	3,75 x 18
↑ mm	51,5
	6



DE	STERNBANDTÜLLE OFFEN
GB	STAR RIBBON TUBE OPEN
IT	DELIZIA APERTA
ES	CINTA ESTRIADA ABIERTA

#	197419
↔ mm	1,65 x 22
↑ mm	52
	6



DE	DREILOCHTÜLLE
GB	THREE HOLES TUBE
IT	A TRE FORI
ES	A TRES FOROS

#	197420
Ø mm	3,0
↑ mm	50
	6



DE	VERMICELLE KLEIN
GB	BIRD NEST TUBE SMALL
IT	VERMICELLI, PICCOLA
ES	VERMICELLI, PEQUEÑA

#	197421
Ø mm	1,0
↑ mm	45,5
	6



DE	VERMICELLE GROSS
GB	BIRD NEST TUBE LARGE
IT	VERMICELLI, GRANDE
ES	VERMICELLI, GRANDE

#	197422
Ø mm	2,9
↑ mm	52,5
	6



DE	VERMICELLE KLEIN
GB	BIRD NEST TUBE SMALL
IT	VERMICELLI, PICCOLA
ES	VERMICELLI, PEQUEÑA

#	197423
Ø mm	2,0
↑ mm	45
	6



DE	VERMICELLE GROSS
GB	BIRD NEST TUBE LARGE
IT	VERMICELLI, GRANDE
ES	VERMICELLI, GRANDE

#	197424
Ø mm	4,5
↑ mm	45
	6



DE	ST. HONORÉ
GB	ST. HONORÉ
IT	ST. HONORÉ
ES	ST. HONORÉ

#	197425
Ø mm	12
↑ mm	41
	6



DE	ST. HONORÉ
GB	ST. HONORÉ
IT	ST. HONORÉ
ES	ST. HONORÉ

#	197426
Ø mm	14
↑ mm	39
	6



DE	ST. HONORÉ
GB	ST. HONORÉ
IT	ST. HONORÉ
ES	ST. HONORÉ

#	197427
Ø mm	15
↑ mm	46
	6



DE	ST. HONORÉ
GB	ST. HONORÉ
IT	ST. HONORÉ
ES	ST. HONORÉ

#	197403
↔ mm	11 x 21
↑ mm	53
	6



DE	GARNIERTÜLLE
GB	GARNISHING TUBE
IT	BOCCHETTA DECORATRICE
ES	BOQUILLA

#	197428
Ø mm	11
↑ mm	51
	6



DE	GARNIERTÜLLE
GB	GARNISHING TUBE
IT	BOCCHETTA DECORATRICE
ES	BOQUILLA

#	197429
Ø mm	13
↑ mm	48
	6



DE	GARNIERTÜLLE
GB	GARNISHING TUBE
IT	BOCCHETTA DECORATRICE
ES	BOQUILLA

#	197430
Ø mm	15
↑ mm	52
	6



DE	STERNBANDTÜLLE
GB	STAR RIBBON TUBE
IT	BOCCHETTA DELIZIA
ES	BOQUILLA

#	197303
Ø mm	19
↑ mm	52
	6



DE	MAGNOLIE
GB	MAGNOLIA
IT	MAGNOLIA
ES	MOGNOLIA

#	197570
Ø mm	25
↑ mm	42
	6



DE	TULPE
GB	TULIP
IT	TULIPANO
ES	TULIPÁN

#	197571
Ø mm	23
↑ mm	42
	6



DE	ROSE
GB	ROSE
IT	ROSA
ES	ROSA

#	197572
Ø mm	25
↑ mm	42
	6



DE	TULPE
GB	TULIP
IT	TULIPANO
ES	TULIPÁN

#	197573
Ø mm	23
↑ mm	42
	6



DE	NARZISSE
GB	DAFFODIL
IT	NARCISO
ES	NARCISO

#	197574
Ø mm	25
↑ mm	42
	6



DE	TULPE
GB	TULIP
IT	TULIPANO
ES	TULIPÁN

#	197575
Ø mm	25
↑ mm	42
	6



DE	TULPE
GB	TULIP
IT	TULIPANO
ES	TULIPÁN

#	197576
Ø mm	25
↑ mm	42
	6



DE	TULPE
GB	TULIP
IT	TULIPANO
ES	TULIPÁN

#	197577
Ø mm	25
↑ mm	42
	6



DE	BLÜMCHEN
GB	FLOWERS
IT	FIORELLINO
ES	FLORECITA

#	197578
Ø mm	25
↑ mm	42
	6



DE	BLÜMCHEN
GB	FLOWERS
IT	FIORELLINO
ES	FLORECITA

#	197579
Ø mm	25
↑ mm	42
	6



DE	BLÜMCHEN
GB	FLOWERS
IT	FIORELLINO
ES	FLORECITA

#	197580
Ø mm	25
↑ mm	42
	6



DE	BLÜMCHEN
GB	FLOWERS
IT	FIORELLINO
ES	FLORECITA

#	197581
Ø mm	25
↑ mm	42
	6



DE	BLÜMCHEN
GB	FLOWERS
IT	FIORELLINO
ES	FLORECITA

#	197582
Ø mm	25
↑ mm	42
	6



DE	BLÜMCHEN
GB	FLOWERS
IT	FIORELLINO
ES	FLORECITA

#	197583
Ø mm	25
↑ mm	42
	6



DE	BLÜMCHEN
GB	FLOWERS
IT	FIORELLINO
ES	FLORECITA

#	197584
Ø mm	25
↑ mm	42
	6

DE	SPRITZTÜLLEN-SET
GB	SET OF DECORATING TUBES
IT	SET BOCCHETTE, INOX
ES	CAJA SURTIDA DE BOQUILLAS

Tüllen-Set aus Edelstahl, inklusive Adapter, Box aus stabilem Kunststoff

made of stainless steel, with adapter, box made of sturdy plastic

#		↑ mm	
197032	55	30	1
197033	29	30	1
197060	38	50	1



DE	TÜLLEN-ADAPTER - DOPPELT
GB	EXTERNAL PIPING TUBE ADAPTER - DOUBLE
IT	ADATTATORE PER BOCCHETTE - DOPPIO
ES	ADAPTADOR PARA BOQUILLAS - DOBLE

Material: BPA-frei, Farbe glasklar, 3-teilig, spülmaschinengeeignet, für Einwegspritzenbeutel 50 µ bis 75 µ

BPA-free, colour crystal clear quality, 3 pieces, dishwasher proof, for disposable pastry bags 50 µ to 75 µ

#	Ø mm	↑ mm	
<input checked="" type="checkbox"/> 196660	48	63	1 Set



13



i Mit allen "Multi-Deko"-Tüllen verwendbar. / Can be used with all "Multi-Deko"-tubes. / Utilizzare tutte "Multi-Deko"-bochette. / Para usar con todo "Multi-Deko"-Boquillas.





Adapter mit Tülle zum Aufstecken / twist-on adapter



Adapter mit Verschluss-Kappe / adapter with cap



DE	TÜLLENKASSETTEN-SET "MULTI-DEKO"
GB	INTERCHANGABLE PIPING TUBES SET "MULTI-DEKO"
IT	SET BOCCHETTE ASSORTITE "MULTI-DEKO"
ES	SURTIDO BOQUILLAS "MULTI-DEKO"

Material: BPA-frei, Farbe glasklar
 Höhe: ca. 3,0 – 5,0 cm
 Wandmontage möglich,
 inkl. Deckel für hygienische Aufbewahrung,
 spülmaschinengeeignet

BPA-free, colour crystal clear quality
 height: 3,0 – 3,5 cm
 wall fastening possible,
 incl. lid for hygienical storage,
 dishwasher proof

	#		Ø mm		
<input checked="" type="checkbox"/>	196600	8 Lochtüllen / 8 plain tubes 2 Adapter / 2 adapters 2 Verschlüsse / 2 lids 1 Tüllenbürste / 1 brush	1, 2, 3, 5, 7, 9, 13, 15	1 Set	
<input checked="" type="checkbox"/>	196610	8 Sterntüllen / 8 star tubes 2 Adapter / 2 adapters 2 Verschlüsse / 2 lids 1 Tüllenbürste / 1 brush	4, 5, 7, 9 (6 Zähne/points) 7, 9, 11, 13 (8 Zähne/points)	1 Set	
<input checked="" type="checkbox"/>	196620	8 Dekortüllen / 8 decor tubes 1 Berliner Tülle / 1 fritter tube 2 Adapter / 2 adapters 2 Verschlüsse / 2 lids		1 Set	
<input checked="" type="checkbox"/>	196630	8 franz. Sterntüllen / 8 french star tubes 2 Adapter / 2 adapters 2 Verschlüsse / 2 lids 1 Tüllenbürste / 1 brush	4,5 / 5,5 / 6 / 7,5 / 8 / 8 / 9 / 10	1 Set	

scharfe Konturen für perfektes Dekorieren / sharp teeth for perfect decorating.



Art. 196600

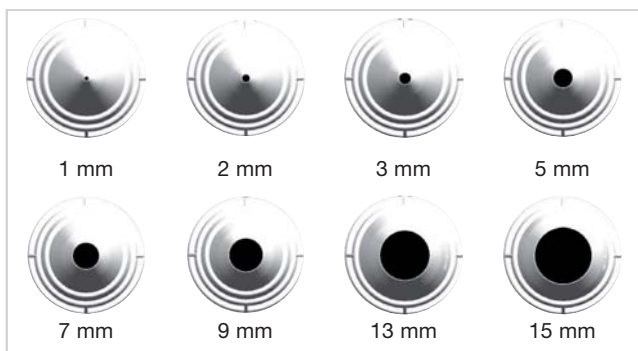

Art. 196610

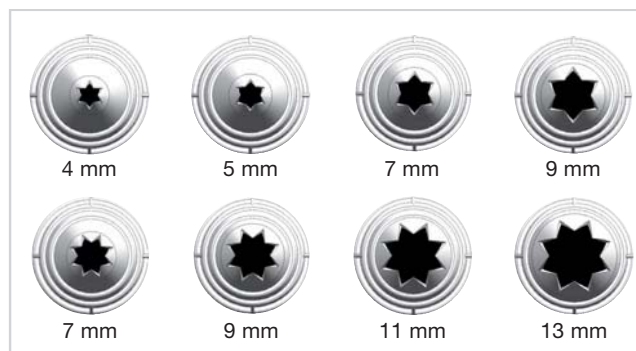

Art. 196620

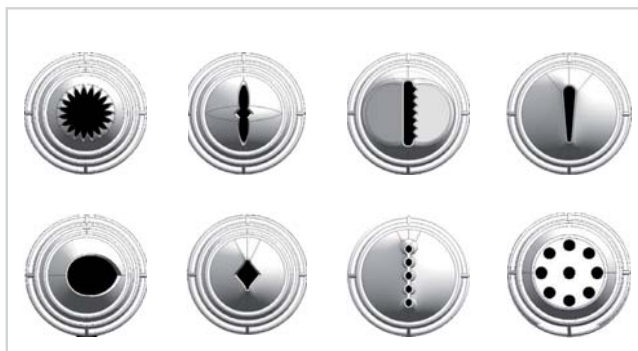

Art. 196630

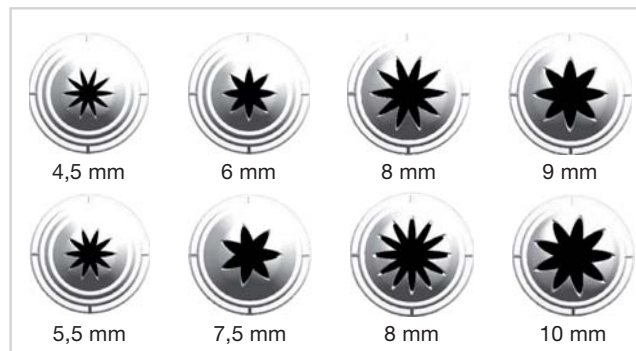

13





DE	STERNTÜLLEN
GB	STAR TUBES
IT	BOCCHETTE FORO STELLA IN POLIPROPILENE
ES	BOQUILLAS ESTRELLA

Material: PP, Farbe elfenbein
Höhe: 6 cm

made of PP, colour ivory
height: 6 cm



#	Ø mm	Größe / size	
196500	3	3	6
196501	5	5	6
196502	7	7	6
196503	9	9	6
196504	11	11	6
196505	13	13	6
196506	15	15	6
196507	17	17	6



DE	LOCHTÜLLEN
GB	PLAIN TUBES
IT	BOCCHETTE FORO TONDO IN POLIPROPILENE
ES	BOQUILLAS LISAS

Material: PP, Farbe elfenbein
Höhe: 6 cm

made of PP, colour ivory
height: 6 cm



#	Ø mm	Größe / size	
196520	5	3	6
196521	7	5	6
196522	9	7	6
196523	11	9	6
196524	13	11	6
196525	15	13	6
196526	17	15	6
196527	19	17	6
196528	26	24	6



DE	TÜLLEN-SET
GB	TUBES SET
IT	SET DI BOCCHETTE IN POLIPROPILENE
ES	JUEGO DE BOQUILLAS

Material: PP, Farbe elfenbein
Höhe: 6 cm
6 verschiedene Tüllen

made of PP, colour ivory
height: 6 cm
6 different tubes



#	Ø mm	Größe / size	
196530	3, 5, 7, 9, 11, 13	3, 5, 7, 9, 11, 13	1 Set
196540	5, 7, 9, 11, 13, 15	3, 5, 7, 9, 11, 13	1 Set

DE	TÜLLENKASSETTEN-SET
GB	PIPING TUBES SET
IT	SET BOCCHETTE ASSORTITE IN POLIPROPILENE
ES	SURTIDO BOQUILLAS

Material: PP, Farbe elfenbein; Höhe: 6 cm

made of PP, colour ivory; height: 6 cm

12 verschiedene Tüllen

12 different tubes

#		Größe / size		
196550	4 Sterntüllen / 4 star tubes	3, 5, 7, 9	1 Set	
	4 Lochtüllen / 4 plain tubes	5, 7, 9, 11		
196560	4 Garniertüllen / 4 decorating tubes	Grattülle, Rosentülle, Sternbandtülle links und rechts / rose, star ribbon, ridge left and right	1 Set	
	4 Sterntüllen / 4 star tubes	11, 13, 15, 17		
196560	4 Lochtüllen / 4 plain tubes	11, 13, 15, 17	1 Set	
	4 Garniertüllen / 4 decorating tubes	Blatt-, Doppelloch-, Rosen- und Riefentülle / Leaf, double hole, rose and flute tip		



Material: PP, Farbe elfenbein

made of PP, colour ivory

Höhe: ca. 3,0 – 3,5 cm

height: 3,0 – 3,5 cm

**20 verschiedene Tüllen und
2 Adapter (2-tlg.)**

**20 different tubes and
2 adapters (2 pcs.)**

#		Größe / size		
196570	4 Sterntüllen / 4 star tubes	2, 4, 6, 8	1 Set	
	8 Lochtüllen / 8 plain tubes	2 – 8, 10		
196580	8 Garniertüllen / 8 decorating tubes	1 – 8	1 Set	
	2 Adapter (2-tlg.) / 2 adapters (2 pcs.)	3, 5, 7, 10		
196580	4 Sterntüllen / 4 star tubes	1 – 8	1 Set	
	4 Lochtüllen / 4 plain tubes	3, 5, 7, 10		
196580	8 Garniertüllen / 8 decorating tubes	1 – 8	1 Set	
	2 Adapter (2-tlg.) / 2 adapters (2 pcs.)	3, 5, 7, 10		



13

Lebensmittelfarben
 Food colourings
 Colori alimentari
 Colorantes alimentarios



DE	AIRBRUSH-SET
GB	AIRBRUSH-SET
IT	KIT AEROGRAFCO
ES	KIT AEROGRAFO

Starter-Set „Airbrush“

Starter-Kit „Airbrush“



#			
151500	1 Kompressor / 1 compressor Art. 151420 1 Airbrush-Pistole / 1 Airbrush Art. 151460 je Lebensmittelfarbe / each Colouring: ● 266000, ● 266003, ● 266006, ● 266007, ● 266009, ● 266012	1 Set	



DE	AIRBRUSH KOMPRESSOR
GB	AIRBRUSH COMPRESSOR
IT	COMPRESSORE PER PENNA AEROGRAFCA
ES	COMPRESOR PARA EQUIPO AEROGRAFO

tragbar, 2,5 bar
Gewicht: 2,2 kg
57 dbA
Abmessungen: 135 x 230 x 190 mm

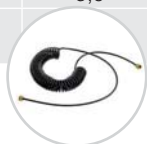

portable, 2,5 bar
weight: 2,2 kg
57 decibel
dimensions: 135 x 230 x 190 mm

#	Ltr. / min.				
151400	5,0	230 V/50 Hz	60 W	1	
151432		Verbindungsschlauch + Nippel connection hose			



tragbar, 3 bar
Gewicht: 2,6 kg
47 dbA
Abmessungen: 235 x 185 x 190 mm

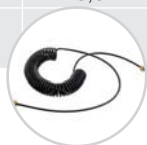

portable, 3 bar
weight: 2,6 kg
47 decibel
dimensions: 235 x 185 x 190 mm

#	Ltr. / min.				
151410	8,0	230 V/50 Hz	80 W	1	
151430		Verbindungsschlauch/ connection hose			



automatischer Kompressor mit Filter-/Druckregler und Spiralschlauch
tragbar, 3,8 bar
Gewicht: 5,1 kg
45 dbA
Abmessungen: 170 x 280 x 220 mm

automatic compressor with filter regulator and coiled hose
portable, 3,8 bar
weight: 5,1 kg
45 decibel
dimensions: 170 x 280 x 220 mm

#	Ltr. / min.				
151420	15,0	230 V/50 Hz	115 W	1	
151430		Verbindungsschlauch/ connection hose			

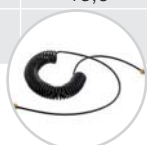

14

DE	AIRBRUSH-PISTOLEN
GB	AIRBRUSHES
IT	PENNE AEROGRAFICHE
ES	EQUIPO AERÓGRAFO

aus Metall
made of steel

#		Kapazität/ capacity cm ³	Düse/ nozzle mm		
151450	doppelt/double action	2,0	0,2	1	
151460	doppelt/double action	7,0	0,3	1	





DE	LEBENSMITTELFARBEN FÜR AIRBRUSH
GB	FOOD COLOURINGS FOR AIRBRUSH
IT	COLORI ALIMENTARI PER AEROGRAFO
ES	COLORANTE LIQUIDO PARA AEROGRAFO

für Airbrush, Anfärben von Sahne, Getränken, Speiseeis, Zucker, Pasten, Gelatine und Marzipan. Nicht für Schokolade geeignet. Volumen: 100 ml.

for Airbrush, direct colouring of creams, drinks, ice-creams, jellies, sugar, pastes, jelly and marzipan. Not suitable for chocolate. Volume: 100 ml.

#			
266000	● Rot/red	1	
266002	● Rosa/pink	1	
266003	● Zitronen-Gelb/lemon yellow	1	
266004	● Ei-Gelb/egg yellow	1	
266006	● Grün/green	1	
266007	● Himmel-Blau/sky blue	1	
266009	● Schokoladen-Braun/chocolate brown	1	
266010	● Orange/orange	1	
266011	● Violett/violet	1	
266012	● Schwarz/black	1	
266013	○ Weiss/white	1	



DE	LEBENSMITTELFARBEN FÜR AIRBRUSH MIT METALLIC-EFFEKT
GB	FOOD COLOURINGS WITH PEARLY EFFECT
IT	COLORI ALIMENTARI PER AEROGRAFO AD EFFETTO METALLIZATO
ES	COLORANTE LIQUIDO PARA AEROGRAFO EFECTO PERLADO

#			
266112	● Gold/gold	1	
266113	● Silber/silver	1	



DE	LEBENSMITTEL-PUDERFARBEN
GB	POWDER COLOURS
IT	POLVERI ALIMENTARI LIPOSOLUBILI
ES	COLORANTE EN POLVO

Lebensmittelechter Puder, hohe Reinheit (fettlöslich). Zum Dekorieren und Vermengen mit Alkohol und Massen aus weißer Schokolade, Sahne, Pasten, Zucker und Butter. Auftragbar auch mit einem Pinsel.

Foodsafe powder, with high degree purity (liposoluble). For decoration and mixing with alcohol and fat masses like white chocolate, cream, paste, sugar and butter. Useable also with a pastry brush.



#		gr.		
266400	● Gelb/yellow	25	1	
266401	● Rosa/pink	25	1	
266404	● Orange/orange	25	1	
266405	● Blau/blue	25	1	
266406	● Grün/green	25	1	
266407	○ Weiß/white	25	1	
266409	● Karbon-Schwarz / carbon black	25	1	



14

DE	LEBENSMITTEL-PUDERFARBEN MIT GLITZER-EFFEKT
GB	POWDER COLOURS WITH GLITTER EFFECT
IT	POLVERI ALIMENTARI AD EFFETTO PERLATO
ES	COLORANTE EN POLVO PERLADO

Lebensmittelechter Puder, hohe Reinheit. Zum Dekorieren und Vermengen mit weißer und brauner Schokolade, Sahne, Pasten, Zucker, Marzipan, Butter und Halbgefrorenes. Auftragbar auch mit einem Pinsel.

Foodsafe powder, with high degree purity. For decoration and mixing of white and brown chocolate, cream, paste, sugar, marzipan, butter and semifredo. Useable also with a pastry brush.



#		gr.		
266450	● Gold/brillant gold	25	1	
266452	● Silber/brillant silver	25	1	
266454	● Bronze/bronze	25	1	
266455	● Rubin-Rot/ruby red	25	1	



DE	LEBENSMITTEL-FARBSPRAYS	
GB	FOOD COLOUR SPRAYS	
IT	COLORI ALIMENTARI IN SPRAY	
ES	SPRAY ALIMENTARIO	



Lebensmittelechter Farbspray, hohe Reinheit. Zum Dekorieren von Lebensmitteln, speziell für Sahne, Zucker, Pasten, Waffeln, Schokolade und Gebäck ohne Beeinflussung des Geschmacks. Volumen: 100 ml

Food safe colour spray for decoration of food products, especially for cream, sugar, paste, waffles, chocolate and pastries without affecting the taste. Volume: 100 ml





#			
266500	 Gelb/yellow	1	
266501	 Rosa/pink	1	
266502	 Grün/green	1	
266503	 Rot/red	1	
266504	 Himmel-Blau/sky blue	1	
266505	 Schokoladen-Braun/chocolate brown	1	

DE	LEBENSMITTEL-FARBSPRAYS MIT GLITZER-EFFEKT	
GB	FOOD COLOUR SPRAYS WITH GLITTER EFFECT	
IT	COLORE ALIMENTARE IN SPRAY AD EFFETTO PERLATO	
ES	SPRAY ALIMENTARIO PERLADO	



Lebensmittelechter Farbspray, hohe Reinheit. Zum Dekorieren von Lebensmitteln, speziell für Sahne, Zucker, Schokolade und Marzipan ohne Beeinflussung des Geschmacks. Volumen: 100 ml

Food safe colour spray for decoration of food products, especially for cream, sugar, chocolate and pastries without affecting the taste. Volume: 100 ml

#			
266550	 Gold/gold	1	
266551	 Silber/silver	1	
266554	 Rubin-Rot/ruby red	1	
266555	 Rosa/pink	1	

DE	FARBSTIFTE	
GB	MARKING PENS	
IT	PENNARELLI ALIMENTARI	
ES	LAPICES DE COLORES (PARA USO ALIMENTARIO)	



Lebensmittelstifte, ideal für die Dekoration. Mit diesen vielseitigen Stiften kann man praktisch alle Oberflächen beschriften. Für Lebensmittel wie z.B. Zuckerguss, Gebäck, Schokolade und Waffeln. Ideal zur Verzierung auch von Brot, Käse, Pralinen oder Glasurplatte.

Food safe ink pen ideal for decorating. These versatile pens can be used to write on virtually any surface. For foodstuffs such as icing, pastry, chocolate, and wafers. Suitable also for decorating bread, cheese, candy or frosted sheets.

#			
266800	8 Farbstifte / 8 Marking pens Rot/red, Rosa/pink, Gelb/yellow, Grün/green, Orange/orange, Blau/blue, Braun/brown, Schwarz/black	1 Set	

DE	LEBENSMITTELSPRAY "EIS"	
GB	FOOD SPRAY "ICE"	
IT	SPRAY ALIMENTARE RAFFREDDANTE "ICE"	
ES	SPRAY REFRIGERANTE PARA USO ALIMENTARIO	

Lebensmittelechtes Vereisungsspray für Zucker und Schokolade zum schnellen Vereisen.
Volumen: 400 ml

Food safe freezing spray for a fast freezing of soft consistencies such as sugar and chocolate. Unidirectional spray and valve.
Volume: 400 ml

#			
266600	<input type="radio"/> Eisspray/ice spray	1	



DE	LEBENSMITTELSPRAY GLANZ	
GB	FOOD SPRAY "SHINY"	
IT	SPRAY ALIMENTARE GOMMALACCA "SHINY"	
ES	SPRAY EFECTO BRILLO PARA USO ALIMENTARIO	

Lebensmittelechtes Glanzspray, auch zum "Verschließen" von Schokolade und Zuckeroberflächen.
Volumen: 400 ml

Food safe "shine" spray for creating a glossy shine on chocolates and iced surfaces while protecting the product from humidity. Volume: 400 ml

#			
266610	<input type="radio"/> Glanzspray/shiny spray	1	



DE	LEBENSMITTELSPRAY "BUTTER"	
GB	FOOD SPRAY "BUTTER"	
IT	SPRAY ALIMENTARE "BURRO DI CACAO"	
ES	SPRAY MANTECA DE CACAO PARA USO ALIMENTARIO	

Lebensmittelechtes Spray (Kakao-Butter), für Marzipan.
Volumen: 400 ml

Food safe cocoa butter spray for adding sheen and protecting products such as marzipan. Volume: 400 ml

#			
266620	<input type="radio"/> Butter-Spray/butter spray	1	



Präsentieren
 Presentation & Display
 Presentazione
 Presentar

So präsentieren Profis!



MADE IN GERMANY



600 x 400	300 x 200	600 x 200	400 x 300	400 x 200
	300 x 200		400 x 300	400 x 200
	300 x 200		400 x 300	400 x 200
GN 1/1 530 x 325	GN 1/2 325 x 265		GN 1/3 325 x 176	GN 2/4 162 x 530
	GN 1/4 162 x 265	GN 1/4 162 x 265	GN 1/3 325 x 176	
			GN 1/3 325 x 176	
			GN 1/3 325 x 176	



Silikonfüße

silicone feet



#	↔ mm	
227142	rund Ø: 16 / Höhe: 2 round Ø: 16 / height: 2	12
227144	quadratisch: oben: 20 x 20; unten: 10 x 10 / H: 7 square: top: 20 x 20; bottom: 10 x 10 / height: 7	7

DE	AUSLAGETABLETTS "MARMOR"
GB	DISPLAY TRAYS
IT	VASSOI DI PRESENTAZIONE
ES	BANDEJA DE PRESENTACIÓN

Material: mehrschichtige Kunststoffplatte

- hygienisch, 100 % lebensmittelecht
- spülmaschinengeeignet
- leicht zu reinigen
- stoß- und abriebfest
- Made in Germany
- Silikonfüße optional

Stärke: 6 mm

Made of multilayer plastic plate

- hygienic, 100 % food safe
- dishwasher proof
- easy to clean
- resisiting to breaking
- Made in Germany
- optional accessory: silicone feet

Thickness: 6 mm



#		↔ mm	
226050		600 x 400	10
226060		600 x 200	10
226070		400 x 300	10
226080		300 x 200	10
226090		400 x 200	10

226120		Ø: 320	10
226130		Ø: 400	10

226140	Tablett rund / round tray	Ø 320 x 465	10
226150	Tablett rechteckig / rectangular tray	600 x 200	10



Art. 226150



Art. 226120 + 226130

15



Art. 226140



GN-Ausführungen

GN size display

#	GN	↔ mm	
226250	1/1	530 x 325	10
226260	1/2	325 x 265	10
226270	1/3	325 x 176	10
226280	1/4	265 x 162	10
226290	2/4	530 x 162	10



SAHARA
DARK

DE	AUSLAGETABLETTS "SAHARA DARK"
GB	DISPLAY TRAYS
IT	VASSOI DI PRESENTAZIONE
ES	BANDEJA DE PRESENTACIÓN

Material: mehrschichtige Kunststoffplatte

- hygienisch, 100 % lebensmittelecht
- spülmaschinengeeignet
- leicht zu reinigen
- stoß- und abriebfest
- Made in Germany
- Silikonfüße optional

Stärke: 6 mm

Made of multilayer plastic plate

- hygienic, 100 % food safe
- dishwasher proof
- easy to clean
- resisiting to breaking
- Made in Germany
- optional accessory: silicone feet

Thickness: 6 mm



#		↔ mm		
226350		600 x 400	10	
226360		600 x 200	10	
226370		400 x 300	10	
226380		300 x 200	10	
226390		400 x 200	10	
226420		Ø: 320	10	
226430		Ø: 400	10	
226440	Tablett rund / round tray	Ø 320 x 465	10	
226450	Tablett rechteckig / rectangular tray	600 x 200	10	

GN-Ausführungen

GN size display

#	GN	↔ mm		
226550	1/1	530 x 325	10	
226560	1/2	325 x 265	10	
226570	1/3	325 x 176	10	
226580	1/4	265 x 162	10	
226590	2/4	530 x 162	10	



DE	AUSLAGETABLETTS "SAHARA LIGHT"
GB	DISPLAY TRAYS
IT	VASSOI DI PRESENTAZIONE
ES	BANDEJA DE PRESENTACIÓN

Material: mehrschichtige Kunststoffplatte

- hygienisch, 100 % lebensmittelecht
- spülmaschinengeeignet
- leicht zu reinigen
- stoß- und abriebfest
- Made in Germany
- Silikonfüße optional

Stärke: 6 mm

Made of multilayer plastic plate

- hygienic, 100 % food safe
- dishwasher proof
- easy to clean
- resisiting to breaking
- Made in Germany
- optional accessory: silicone feet

Thickness: 6 mm



SAHARA LIGHT

#		↔ mm		
226650		600 x 400	10	
226660		600 x 200	10	
226670		400 x 300	10	
226680		300 x 200	10	
226690		400 x 200	10	
226720		Ø: 320	10	
226730		Ø: 400	10	
226740	Tablett rund / round tray	Ø 320 x 465	10	
226750	Tablett rechteckig / rectangular tray	600 x 200	10	



15



GN-Ausführungen

GN size display

#	GN	↔ mm		
226850	1/1	530 x 325	10	
226860	1/2	325 x 265	10	
226870	1/3	325 x 176	10	
226880	1/4	265 x 162	10	
226890	2/4	530 x 162	10	



DE AUSLAGETABLETTS
 GB DISPLAY PLATES
 IT VASSOI DI PRESENTAZIONE
 ES BANDEJA DE PRESENTACIÓN



Alle Artikel aus **Melamin** sind:
 - schnitt- und kratzfest, stapelbar
 - temperaturbeständig von -30 °C bis +70 °C

All products made of **melamine** are:
 - scratch- and cut proof, stackable
 - temperature resistant from -30 °C up to +70 °C



#	↔ mm		
227003	190 x 150 x 17	● schwarz / black	1
227004	190 x 150 x 17	○ weiß / white	1
227007	270 x 210 x 17	● schwarz / black	1
227008	270 x 210 x 17	○ weiß / white	1
227009	300 x 150 x 17	● schwarz / black	1
227010	300 x 150 x 17	○ weiß / white	1
227011	300 x 190 x 17	● schwarz / black	1
227012	300 x 190 x 17	○ weiß / white	1
227013	350 x 240 x 17	● schwarz / black	1
227014	350 x 240 x 17	○ weiß / white	1
227015	420 x 280 x 17	● schwarz / black	1
227016	420 x 280 x 17	○ weiß / white	1
227094	580 x 195 x 20	● schwarz / black	1
227095	580 x 195 x 20	○ weiß / white	1
227096	600 x 400 x 20	● schwarz / black	1
227097	600 x 400 x 20	○ weiß / white	1





Angaben in mm

DE AUSLAGETABLETTS UND AUSLEGESCHALEN
 GB DISPLAY PLATES
 IT VASSOI DI PRESENTAZIONE
 ES BANDEJA DE PRESENTACIÓN



Für Metzgertheke / Fleischertheke mit 84 cm Tiefe. Silikonfüße optional.
 Alle Artikel aus **Melamin** sind:
 • spülmaschinengeeignet
 • schnitt- und kratzfest, stapelbar
 • temperaturbeständig von -30 °C bis +70 °C

For counters in butcher shops with 84 cm depth, silicone feet optional
 All products made of **melamine** are:
 • dishwasher safe
 • scratch- and cut proof, stackable
 • temperature resistant from -30 °C up to +70 °C



15

#	↔ mm		🛒	
227130	280 x 210 x 22	● schwarz / black	48	
227131	280 x 210 x 43	● schwarz / black	24	
227132	280 x 210 x 76	● schwarz / black	24	
227133	420 x 280 x 22	● schwarz / black	18	
227134	420 x 280 x 43	● schwarz / black	12	
227135	420 x 280 x 76	● schwarz / black	12	
227136	280 x 280 x 43	● schwarz / black	24	
227137	280 x 280 x 76	● schwarz / black	12	
227138	280 x 140 x 43	● schwarz / black	24	
227139	280 x 140 x 76	● schwarz / black	24	
227140	210 x 140 x 43	● schwarz / black	48	
227141	210 x 140 x 76	● schwarz / black	36	
227142	Silikonfüße / silicone feet		12	

DE	KUCHENPLATTEN	MF
GB	CAKE PLATES	
IT	PIATTI PER DOLCI	
ES	BANDEJA PARA TARTAS	

Material: **Melamin** (schnitt- und bruchfest) made of **melamine**, (cut and break proof)

#		↔ mm	
227023	Königskuchenplatte, weiß / cake trays, white	400 x 150 x 20	1
227098	Königskuchenplatte, schwarz / cake trays, black	400 x 150 x 20	1

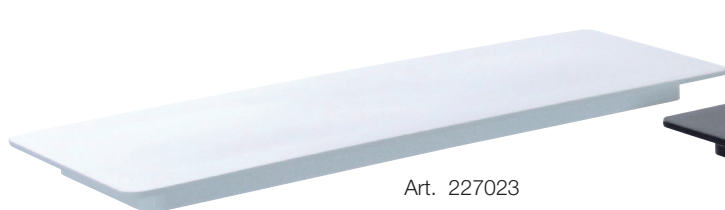

Art. 227023



Art. 227098

DE	AUSSTELLBLECHE / THEKENBLECHE	
GB	DISPLAY TRAYS	
IT	VASSOI DA ESPOSIZIONE	
ES	BANDEJAS PARA EXPOSICION	

Material: Aluminium, pulverbeschichtet Made of aluminum, powder coated
 Farbe: schwarz Colour: black

Ausführung / type: 4 Seiten 90° / 4 sides 90°



#	↗ mm	→ mm	↑ mm	
154095	600	200	10	10
154096	600	400	10	10
154098	400	300	10	10
154099	300	200	10	10



Ausführung / type: 3 Seiten 90°, 1 x 400 mm nach unten / 3 sides 90°, 1 x 400 mm down

#	↗ mm	→ mm	↑ mm	
154097	400	300	10	10



THEKENBLECHE MIT OFFENEN ECKEN WITH OPEN EDGES
 Material: Edelstahl Made of stainless steel

Ausführung / type: 4 Seiten 90° / 4 sides 90°

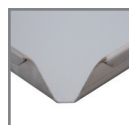

#	↗ mm	→ mm	↑ mm	
154060	600	400	15	10
154061	600	200	15	10
154062	400	400	15	10

DE	AUSSTELLBLECHE / THEKENBLECHE	
GB	DISPLAY TRAYS	
IT	VASSOI DA ESPOSIZIONE	
ES	BANDEJAS PARA EXPOSICION	

SILBER

Material: Aluminium, gebeizt;
mit handelsüblichem Spülmittel reinigen,
nicht für Spülmaschinen geeignet.

SILVER

made of aluminum;
Cleaning with any standard detergent,
not dishwasher proof.



#	→ mm	↗ mm	↑ mm	
154050	400	600	20	10
154051	320	480	20	10
154052	250	400	20	10
154053	200	600	20	10
154059	200	300	20	10
154054	400	600	10	10
154055	320	480	10	10
154056	250	400	10	10

NEW

GOLD

Material: Aluminium, eloxiert;
mit handelsüblichem Spülmittel reinigen,
nicht für Spülmaschinen geeignet.

GOLD

made of anodized aluminum;
Cleaning with any standard detergent,
not dishwasher proof.



#	→ mm	↗ mm	↑ mm	
154070	400	600	20	10
154071	320	480	20	10
154072	250	400	20	10
154073	400	600	10	10
154074	200	600	20	10



CHAMPAGNER

Material: Aluminium, eloxiert;
mit handelsüblichem Spülmittel reinigen,
nicht für Spülmaschinen geeignet.

CHAMPAGNER

made of anodized aluminum;
Cleaning with any standard detergent,
not dishwasher proof.



#	→ mm	↗ mm	↑ mm	
154080	400	600	10	10
154081	320	480	10	10
154082	300	400	10	10
154083	250	400	10	10
154084	200	600	10	10

15

DE	SNACK-BLECH	
GB	SNACK SALES RACK	
IT	TEGLIA PER PANINI	
ES	PORTA BOCADILLOS	

Material: Aluminium, pulverbeschichtet,
schwarz; **nicht spülmaschinengeeignet**

made of aluminum, black, powder
coated, **not dishwasher proof**



#	↔ mm	
154089	600 x 200 x 20	1



DE	AUSLAGETABLETTS
GB	DISPLAY PLATES
IT	VASSOI DI PRESENTAZIONE, ABS
ES	BANDEJA DE PRESENTACIÓN

Material: ABS, schwarz, bruchfest, glatt made of ABS, black, unbreakable, plain

spülmaschinenfest, temperaturbeständig bis ca. + 80 °C dishwasher-proof, heat resistant up to approx. + 80 °C

#	↗ mm	→ mm	↑ mm	
227600	400	600	20	1
227610	300	400	20	1
227620	195	580	20	1
227630	300	190	20	1

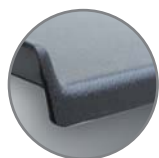

genarbt, abgeklappter Rand: 3 mm surface grained, curved rim: 3 mm

#	↗ mm	→ mm	
227640	400	300	1



genarbt, spülmaschinenfest, temperaturbeständig bis ca. + 80 °C surface grained and dishwasher-safe, heat resistant up to approx. + 80 °C

#	↗ mm	→ mm	↑ mm	
227601	400	600	20	1
227611	300	400	20	1
227621	195	580	20	1
NEW 227622	300	190	20	1

DE	SERVIERTABLETTS OVAL
GB	SERVING TRAYS OVAL
IT	VASSOI OVALI
ES	BANDEJAS OVALADAS

Material: Edelstahl, mit gebördeltem Rand,
hochglanzpoliert

made of stainless steel, with rolling edge,
mirror polishing

#	↔ mm		
154040	145 x 200	1	
154041	180 x 230	1	
154042	195 x 265	1	
154043	220 x 285	1	



Material: Edelstahl, mit gebördeltem Rand,
Oberfläche matt

made of stainless steel, with rolling edge,
Dull surface

#	↔ mm		
155040	145 x 200	1	
155041	180 x 230	1	
155042	195 x 265	1	
155043	220 x 285	1	

NEW



DE	AUSLAGETABLETTS
GB	DISPLAY TRAYS
IT	VASSOI
ES	BANDEJAS

Material: Edelstahl,
mit umgelegtem Rand, poliert

made of stainless steel,
with beaded edge, polished

#	↗ mm	→ mm	↑ mm	
154021	200	160	12	1
154024	300	160	12	1
154025	310	210	12	1
154026	340	240	12	1
154028	400	300	12	1



Material: Edelstahl,
mit geradem Rand, poliert

made of stainless steel,
with plain edge, polished

#	↗ mm	→ mm	↑ mm	
154030	195	145	10	1
154031	280	140	10	1
154032	290	185	10	1
154033	320	220	10	1
154034	380	280	10	1



DE	TORTENPLATTEN	MF
GB	CAKE PLATES	
IT	ALZATE PER TORTA	
ES	PEDESTALES PARA TARTAS	

Tortenplatte-Halbkreis in zwei Farben – aus dickwandigem **Melamin**

- temperaturbeständig von -30 °C bis +70 °C
- schnitt- und kratzfest, stapelbar
- spülmaschinengeeignet
- mit Silikonfüßen

Cake display in 2 colours: heavy, high quality **melamine**; **semi-circle**

- temperature resistant -30 °C up to +70 °C
- scratch proof, stackable
- dishwasher proof
- silicone feet included



#		↔ mm / Ø	↑ mm	
227026	○ weiss / white	160 / 320	30	10
227126	● schwarz / black	160 / 320	30	10



DE	TORTENPLATTEN	MF
GB	CAKE PLATES	
IT	ALZATE PER TORTA	
ES	PEDESTALES PARA TARTAS	

Material: **Melamin** (schnitt- und bruchfest) mit Anti-Rutsch-Füßen

made of **melamine** (cut and break proof) with anti-slip feet



227029, 227025, 227027



227129, 227125, 227127

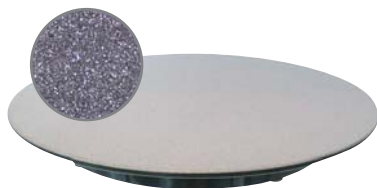

227229, 227225, 227227

#		Ø mm	↑ mm	
227029	○ weiss / white	240	30	1
227025	○ weiss / white	300	30	1
227027	○ weiss / white	320	30	1
227129	● schwarz / black	240	30	1
227125	● schwarz / black	300	30	1
227127	● schwarz / black	320	30	1
227229	● silber / silver	240	30	1
227225	● silber / silver	300	30	1
227227	● silber / silver	320	30	1



DE	TORTENPLATTEN	MF	drehbar
GB	CAKE PLATES		
IT	ALZATE PER TORTA		
ES	PEDESTALES PARA TARTAS		

Material: **Melamin** (schnitt- und bruchfest)
mit Anti-Rutsch-Füßen

made of **melamine** (cut and break proof)
with anti-slip feet

#		Ø mm	↑ mm		
227028	weiss, drehbar, mit Fuß / white, turnable, with foot	320	100	1	
227128	schwarz, drehbar, mit Fuß / black, turnable, with foot	320	100	1	



DE	TORTEN- UND DEKORIERPLATTE, DREHBAR	MF	
GB	TILTING TURNTABLE		
IT	ALZATA PER TORTA, GIREVOLE E INCLINABILE		
ES	SOPORTE GIRATORIO RECLINABLE		

Melamin, Kunststoff, dreh- und schwenk-
bar, stabile Qualität inkl. Anti-Rutsch-Füßen,
rutschfeste Oberfläche

made of **melamine**, plastic, turnable,
tilting, sturdy, with anti-slip feet and top

#	Ø mm	↑ mm		
227220	300	160	1	





 **VIDEO**

www.schneider-gmbh.com
www.schneider-gmbh.com/de/videos.html



DE	TORTENPLATTE, DREHBAR, BATTERIEBETRIEB
GB	CAKE PLATE, ROTATING, BATTERY OPERATION
IT	ALZATE PER TORTA, ROTANTE, FUNZIONAMENTO A BATTERIA
ES	PIASTRA TORTA, ROTANTE, FUNZIONAMENTO A BATTERIA

Automatisch rotierende Tortenplatte für die hochwertige Warenpräsentation.
 Geschwindigkeit: 3,5 Umdrehungen pro Minute. Schaltet automatisch bei Tag ein und bei Nacht aus. Laufzeit ca. ein Jahr mit nur zwei Mono-Batterien.

- Energieversorgung: Batterie
- Farbe: weiß, hochglanz
- Traglast: 5 kg

Automatically rotating cake plate for the high-quality presentation of goods.
 Speed: 3.5 revolutions per minute. Automatically switches on during the day and off at night. Running time approx. one year with only two mono batteries.

- Energy supply: battery
- Colour: white, glossy
- Load capacity: 5 kg

#	Ø mm	↑ mm	
227040	240	80	1





DE	TORTENUNTERSETZER
GB	TART COASTERS
IT	PIATTINI
ES	PLATOS

Material: Kaschierte Pappe, Unterseite weiß

Material: laminated cardboard, white underside

#	Ø mm	↑ mm		
116600	120	2,5	silber / silver	3
116610	140	2,5	silber / silver	3
116620	170	2,5	silber / silver	3
116630	190	2,5	silber / silver	3
116640	220	2,5	silber / silver	3
116650	240	2,5	silber / silver	3
116660	260	2,5	silber / silver	3
116670	290	2,5	silber / silver	3
116680	340	3,5	silber / silver	3
116690	390	3,5	silber / silver	3

#	Ø mm	↑ mm		
116700	120	2,5	gold / gold	3
116710	140	2,5	gold / gold	3
116720	170	2,5	gold / gold	3
116730	190	2,5	gold / gold	3
116740	220	2,5	gold / gold	3
116750	240	2,5	gold / gold	3
116760	260	2,5	gold / gold	3
116770	290	2,5	gold / gold	3
116780	340	3,5	gold / gold	3
116790	390	3,5	gold / gold	3



#	↔ mm	↑ mm		
116800	120 x 120	2,5	silber / silver	3
116810	140 x 140	2,5	silber / silver	3
116820	170 x 170	2,5	silber / silver	3
116830	190 x 190	2,5	silber / silver	3
116840	220 x 220	2,5	silber / silver	3
116850	240 x 240	2,5	silber / silver	3
116860	260 x 260	2,5	silber / silver	3
116870	290 x 290	2,5	silber / silver	3
116880	340 x 340	3,5	silber / silver	3
116890	390 x 390	3,5	silber / silver	3
116895	240 x 340	3,5	silber / silver	3
116896	340 x 440	3,5	silber / silver	3

#	↔ mm	↑ mm		
116900	120 x 120	2,5	gold / gold	3
116910	140 x 140	2,5	gold / gold	3
116920	170 x 170	2,5	gold / gold	3
116930	190 x 190	2,5	gold / gold	3
116940	220 x 220	2,5	gold / gold	3
116950	240 x 240	2,5	gold / gold	3
116960	260 x 260	2,5	gold / gold	3
116970	290 x 290	2,5	gold / gold	3
116980	340 x 340	3,5	gold / gold	3
116990	390 x 390	3,5	gold / gold	3
116995	240 x 340	3,5	gold / gold	3
116996	340 x 440	3,5	gold / gold	3



15

DE	TORTENPLATTEN
GB	CAKE PLATES
IT	ALZATE PER TORTA
ES	PEDESTALES PARA TARTAS



Material: Edelstahl, poliert,
mit Ringfuß, Stärke 1 mm

made of stainless steel, polished,
with round foot, thickness 1 mm

#	Ø mm	↑ mm	
154010	240	30	1
154001	300	30	1
154002	330	30	1
154004	360	30	1

Andere Größen auf Anfrage. / Other sizes upon request.



mit geschlossenem Boden
Material: Edelstahl, matt poliert, Bodenteil aus
einem Stück, Stärke 3,2 mm

with closed bottom
made of stainless steel, dull surface, hygienic
closed bottom part, thickness 3,2 mm

#	↑ Ø mm	↓ Ø mm	↑ mm	
154003	315	220	35	1

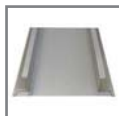

DE	TORTENPLATTE, RECHTECKIG
GB	CAKE PLATE, RECTANGULAR
IT	ALZATE PER TORTE, RETTANGOLARE
ES	SOPORTE PARA EXPONER TARTAS RECTANGULAR



Material: Edelstahl made of stainless steel

#	↔ mm	↑ mm	
154020	395 x 160	30	1



DE	WRAP-HALTER
GB	WRAP HOLDER
IT	PORTA "WRAPS"
ES	PORTA "WRAPS"

Material: Edelstahl made of stainless steel

#	↗ mm	→ mm	↑ mm	
172530	600	67	40	1

Material: Acryl, transparent, mit Boden,
zur Präsentation von 12 Wraps,
Lochdurchmesser 70 mm

made of acryl, transparent, with bottom,
for the presentation of 12 wraps,
diameter of holes 70 mm

#	↗ mm	→ mm	↑ mm	
172520	560	195	50	1

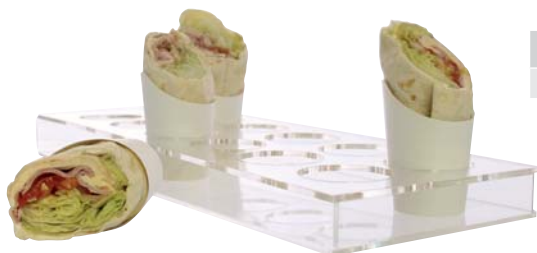

DE	SNACK-VERKAUFSSTÄNDER
GB	SNACK SALES RACKS
IT	PORTA SNACK
ES	PORTA BOCADILLOS

Material: Kunststoff
spülmaschinengeeignet

made of plastic
dishwasher safe

#	↗ mm	→ mm	↑ mm	☰	🛒
227550	600	195	70	6	1
227551	290	190	60	3	1



Art.-Nr. 227551



Art.-Nr. 227550

WELLENFORM

Material: Aluminium, pulverbeschichtet,
 schwarz; **nicht spülmaschinengeeignet**

“WAVY”

made of aluminum, black, powder
 coated, **not dishwasher proof**



#	↗ mm	→ mm	☰	🛒
154090	580	85	6	1
154091	580	170	6	1



WELLENFORM

Material: Edelstahl,
spülmaschinengeeignet

“WAVY”

made of stainless steel,
dishwasher safe

#	↗ mm	→ mm	☰	🛒
154065	370	85	4	1
154066	370	175	4	1
154093	560	85	7	1
154094	560	175	7	1

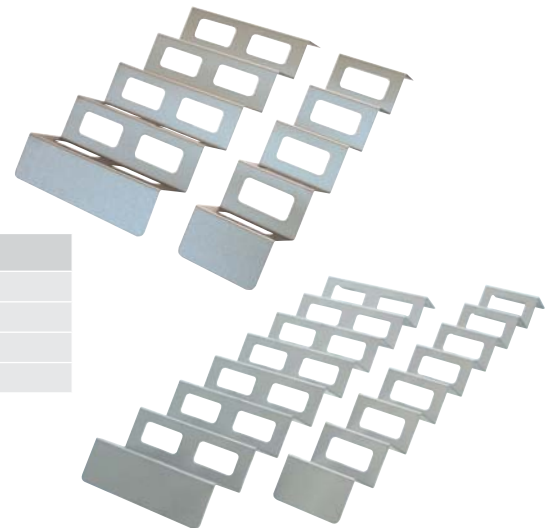

WELLENFORM

Material: ABS, schwarz, bruchfest, glatt
 spülmaschinenfest, temperaturbeständig
 bis ca. + 80 °C

“WAVY”

made of ABS, black, unbreakable, plain
 dishwasher-proof, heat resistant up
 to approx. + 80 °C

#	↗ mm	→ mm	☰	🛒
227651	560	85	6	1
227650	560	168	6	1



15

WELLENFORM

Material: Acryl, transparent

“WAVY”

made of acryl, transparent

#	↗ mm	→ mm	☰	🛒
172500	580	85	6	1
172510	580	170	6	1

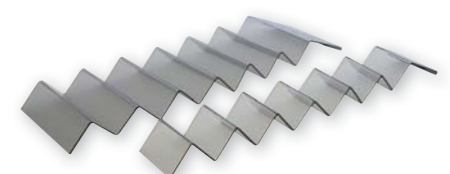

DE	THEKENABTRENNUNG
GB	SEPARATION
IT	BARRIERE PER BANCO
ES	SEPARACIÓN

Material: Acryl PMMA

Made of acrylic PMMA

#	↔ mm	
172700	700 x 170	1
172710	560 x 170	1



DE	ABDECKHAUBEN
GB	PROTECTION COVERS
IT	CAMPANE
ES	TAPAS

Material: PET, Stärke: 1 mm
für 40 x 60 cm-Bleche, stapelbar

made of PET, thickness: 1 mm
for trays 40 x 60 cm, stackable

#	↔ mm	
227180	620 x 425 x 105	1



Material: PS, glasklar

made of PS, crystal clear

#	Ø mm	↑ mm	
227150	300	70	1
227160	300	100	1
227170	320	120	1



Material: PE
unzerbrechlich, milchig

made of PE
unbreakable

#	Ø mm	↑ mm	
227031	300	120	1



DE	TORTENSCHUTZ TS PLAST 1 + 2 GES. GESCH.
GB	CAKE PROTECTION TS PLAST 1 + 2 PAT.
IT	PROTEZIONE PER TORTA TS PLAST 1 + 2
ES	PROTECCIÓN DE TORTA TS PLAST 1 + 2

Material: HPVC glasklar, bewahrt den Torten-Anschnitt vor Austrocknung und schützt das Aroma

Made of HPVC, transparent, protects the aroma by preventing the desiccation of the sliced cake.

#		
113500	Set besteht aus je 25 linke und rechte Teile Set consisting of 25 left and right pieces	1 Set = 50 Stück



i TS Plast 1 und 2 reinigt man mit lauwarmem Wasser (bis zu 50 °C) unter Zugabe eines beliebigen Spülmittels / cleaning of TS Plast 1/2 with warm water (max. 50 °C) and rinse aid/surfactant



DE	KUNSTSTOFF-BAND / -FOLIE
GB	PLASTIC RIBBONS
IT	NASTRI PLASTICI
ES	CINTA DE PLÁSTICO

Material: Folie HPVC glasklar

made of HPVC, crystal clear

#	→ mm	↗ m	μ	
114026	40	300	37	1
114030	60	300	37	1
114050	25	200	80	1
114051	30	200	80	1
114052	35	200	80	1
114053	40	200	80	1
114054	45	200	80	1
114055	50	200	80	1
114056	55	200	80	1
114057	60	200	80	1

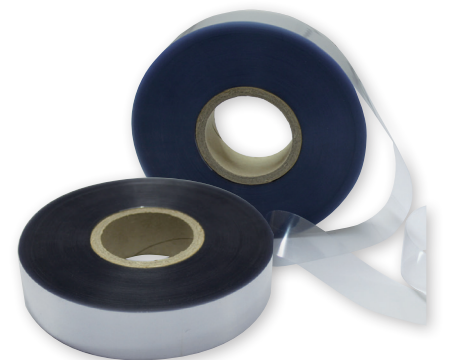

15

Material: Folie HPVC glasklar

made of HPVC, crystal clear

#	→ mm	↗ mm	μ	
114021	60	300	50	1000
114022	40	240	50	1000
114023	30	240	50	1000
114024	25	150	50	1000
114060	400	600	80	50
114061	300	300	80	50



DE	TORTENSPITZEN, WEISS
GB	DOILIES, WHITE
IT	PIZZI PER TORTE, BIANCHI
ES	BLONDAS, BLANKO

#		↔ mm	↑ mm		
116010	RUND / ROUND	100	60	250	5000
116013	RUND / ROUND	120	65	250	2000
116014	RUND / ROUND	140	80	250	2000
116017	RUND / ROUND	165	95	250	2000
116018	RUND / ROUND	190	110	250	2000
116022	RUND / ROUND	220	125	100	2000
116026	RUND / ROUND	240	150	100	2000
116028	RUND / ROUND	270	160	100	2000
116030	RUND / ROUND	290	180	100	2000
116033	RUND / ROUND	300	190	100	2000
116034	RUND / ROUND	320	200	100	2000
116036	RUND / ROUND	340	220	100	1000
116038	RUND / ROUND	360	240	100	1000
116040	RUND / ROUND	380	240	100	1000
116046	RUND / ROUND	420	250	100	1000

#		↔ mm		
116100	OVAL	180 x 260	250	10000
116110	OVAL	160 x 230	250	2000
116130	OVAL	210 x 320	250	2000
116210	OVAL	320 x 450	100	2000
116410	RECHTECKIG / RECTANGULAR	170 x 300	100	1000
116430	RECHTECKIG / RECTANGULAR	200 x 400	100	1000
116440	RECHTECKIG / RECTANGULAR	300 x 400	100	1000
116450	RECHTECKIG / RECTANGULAR	350 x 450	100	1000
116480	RECHTECKIG / RECTANGULAR	250 x 370	100	1000

Art. 116010 bis 116046



Art. 116100 bis 116210



Art. 116400 bis 116480



DE	TORTENSPITZEN-SET
GB	SET OF DOILIES FOR CAKE STANDS
IT	SET DI PIZZI PER TORTE
ES	JUEGO DE BLONDAS

für 3- und 4-teiligen Tortenständer

for cake stands with 3 and 4 tiers

#	für / for: Ø mm	
116333	3-teilig / 3-tiers (200 / 260 / 320)	à 25 Stk. / pcs.
116444	4-teilig / 4-tiers (200 / 260 / 320 / 400)	à 25 Stk. / pcs.



DE	ETAGEN-TORTENSTÄNDER
GB	CAKE STANDS
IT	ALZATE PER TORTA IN ALLUMINIO
ES	PEDESTALES PARA TARTAS, ALUMINIO

sehr stabile Ausführung, aus Aluminium
für Hochzeiten, Buffets in der Gastronomie
oder für Warenpräsentationen

Abstand zwischen den Etagen 16,5 cm

sturdy, made of aluminum
usable for wedding cakes, buffets or for
displaying pastries etc.

distance between tiers 16,5 cm

#		↑ mm	Ø mm	
146003	3	380	200/260/320	1
146004	4	546	200/260/320/400	1
146005	5	712	200/260/320/400/450	1
146006	6	878	200/260/320/400/450/500	1
146007	7	1044	160/200/260/320/400/450/500	1
146008	8	1210	160/200/260/320/400/450/500/550	1



Art. 146003



Art. 146004



Art. 146005



Art. 146007

DE	ERSATZTEILE
GB	SPARE PARTS
IT	PEZZI DI RICAMBIO
ES	DISCO DE REPUESTO

#	→ mm	↔ mm	
148016	Ersatzscheibe / disc	160	1
148020	Ersatzscheibe / disc	200	1
148026	Ersatzscheibe / disc	260	1
148032	Ersatzscheibe / disc	320	1
148040	Ersatzscheibe / disc	400	1
148045	Ersatzscheibe / disc	450	1
148050	Ersatzscheibe / disc	500	1
148051	Ersatzscheibe / disc	550	1
148002	Kopfschraube / head screw		1
148003	Schraube für Fuß / screw for foot		1
148004	Außenfuß mit Schraube / outside foot with screw		1
148005	Zwischenstück (Säule) / connection (pillar)	165	1
148007	Zwischenstück (Säule) / connection (pillar)	82	1
148008	Zwischenstück (Säule) / connection (pillar)	52	1
148006	Mittelfuß / middle foot		1
148001	Mittellochsausstecher aus Edelstahl / center hole cutter made of stainless steel		1



Art. 148001



148008 148007 148005



DE	ETAGEN-TORTENSTÄNDER
GB	CAKE STANDS
IT	ALZATE PER TORTA
ES	PEDESTALES PARA TARTAS

sehr stabile Ausführung, aus Aluminium, für Hochzeiten, Buffets in der Gastronomie oder für Warenpräsentationen, **individuell gestaltbar**

sturdy, made of aluminum usable for wedding cakes, buffets or for displaying pastries etc., **individually designable**

#		Ø mm	
146030	4	200/260/260/320	1
146031	Verbindungsstück / connecting piece		1



#		↑ mm	Ø mm	
146040	5	380	200/2 x 260/2 x 320	1



Material: Aluminium, mit rechteckigen Scheiben, sehr stabile Ausführung
Abstand zwischen den Etagen 16,5 cm

made of aluminum, with rectangular discs, sturdy, distance between tiers 16,5 cm

#		Ø mm)	
149043	3	160x160/185x225/210x290	1
149044	4	160x160/185x225/210x290/235x355	1
149045	5	160x160/185x225/210x290/235x355/260x420	1



mit vorspringenden Auslegern
schwerer Fuß, Aluminium
Abstand zwischen den Etagen 16,5 cm

made of aluminum, with heavy foot
distance between tiers 16,5 cm

#		Ø mm	
149004	4-Etagen / 4-tiers	320	1
149006	6-Etagen / 6-tiers	320	1



Erstteile / spare parts

149007	Ausleger / extension arm	1
149008	Schraube / screw	1
149009	Mutter / screw nut	1
149010	Sockel / stand	1

DE	ETAGEN-TORTENSTÄNDER EDELSTAHL
GB	CAKE STANDS STAINLESS STEEL
IT	ALZATE PER TORTA, ACCIAIO, INOX
ES	PEDESTALES PARA TARTAS, ACERO FINO

sehr stabile Ausführung, rostfreier Edelstahl, für Hochzeiten, Büffets in der Gastronomie oder für Warenpräsentationen



sturdy, made of stainless steel, usable for wedding cakes, buffets or for displaying pastries etc.

#		↑ mm	Ø mm	
146050	3	380	240 / 300 / 350	1
146051	4	540	180 / 240 / 300 / 350	1
146052	5	710	180 / 240 / 300 / 350 / 400	1



elegantes Design, schwerer Fuß, sehr stabile Ausführung, rostfreier Edelstahl, für Hochzeiten, Büffets in der Gastronomie oder für Warenpräsentationen

smart design, heavy feet, sturdy, made of stainless steel, usable for wedding cakes, buffets or for displaying pastries etc.



#		↔ mm	
146060	4	760 x 590 x 360	1



DE	ETAGEN-TORTENSTÄNDER
GB	CAKE STANDS
IT	ALZATE PER TORTA
ES	PEDESTALES PARA TARTAS

Material: Aluminium.
sehr stabile Ausführung

made of aluminum,
sturdy

#		↔ mm	↑ mm	
146100	3	160 / 225 / 290	380	1
146110	5	160 / 225 / 290 / 355 / 420	710	1
146120	4	255 x 220 / 235 x 200 / 235 x 200 / 195 x 170	50 / 220 / 385 / 540	1



Art. 146100



Art. 146110





Art. 146120

DE	ETAGEN-TORTENSTÄNDER
GB	CAKE STANDS
IT	ALZATE PER TORTA
ES	PEDESTALES PARA TARTAS

sehr stabile Ausführung, aus lackiertem Stahl, Farbe weiß; für Hochzeiten, Büffets in der Gastronomie oder für Warenpräsentationen

sturdy, made of lacquered steel, colour white; usable for wedding cakes, buffets or for displaying pastries etc.

#			→ mm	↑ mm	 kg	
146070	Treppe links / stairs left	5	180, 220, 240, 260, 280	520	6,1	1
146071	Treppe rechts / stairs right	5	180, 220, 240, 260, 280	520	6,1	1
146072	Treppe / stair	7	7x 240	750	8,2	1



Art. 146070



Art. 146071





Art. 146072

DE	MUFFINSTÄNDER
GB	STAND FOR MUFFINS
IT	ALZATA PER MUFFIN
ES	PEDESTAL PARA MUFFIN

Material: Aluminium, stabile Ausführung, für 18 Muffins, Ø: 60 mm

made of aluminum, sturdy, for 18 muffins, Ø: 60 mm

#		↑ mm	→ mm	
146130	3	380	200 / 260 / 320	1



DE	ETAGEN-TORTENSTÄNDER
GB	CAKE STANDS
IT	ALZATE PER TORTA
ES	PEDESTALES PARA TARTAS

Material: weißer Kunststoff

made of white plastic

#		Ø mm	
200108	2	200 / 340	1
200103	3	200 / 250 / 340	1
200104	4	200 / 250 / 320 / 340	1
200105	5	200 / 250 / 320 / 400 / 440	1

Erstteile / spare parts

200106	Mittelfuß / middle foot	1
200102	Schraube / screw	1
200109	Zwischenstück (Säule) /connection (pillar)	1



Art. 200108



Art. 200103



Art. 200104





Art. 200105

DE	ETAGEN-TORTENSTÄNDER
GB	CAKE STANDS
IT	ALZATE PER TORTA
ES	PEDESTALES PARA TARTAS

Material: weißer Kunststoff

made of white plastic

#	↔ mm		Ø mm	↑ mm	
200190	520 x 115 x 43	4	280	440	1
201100	Ø: 280, 250	3	280	250	1
201120	modular gestaltbar / to arrange individually / Ø: 350	7	280	750	1

15



Art. 200190



Art. 201100



Art. 201120



DE	ETAGEN-TORTENSTÄNDER
GB	CAKE STANDS
IT	ALZATE PER TORTA
ES	PEDESTALES PARA TARTAS

Material: weißer Kunststoff
 Spülmaschinenfest, zur einmaligen
 oder mehrmaligen Verwendung
 Stecksystem – einfach zu montieren.
 Jede Scheibe benötigt 4 Säulen.

Made of white plastic.
 Dishwasher safe, for single or multiple use
 Plug-in system – easy to install.
 Each disc requires 4 columns.

#	Ø mm	
202400	150	1
202401	175	1
202402	200	1
202403	225	1
202404	250	1
202405	275	1
202406	300	1
202407	325	1
202408	350	1
202409	375	1
202410	400	1
202411	450	1

#	↑ mm	
202412	75	12
202413	150	12
202414	225	12

DE	SAHNE-ABDECKPAPIERE "PERGAMYN"
GB	CREAM COVERS "GLASSINE"
IT	CARTE ANTI-ADESIVE "PERGAMYN"
ES	HOJAS SEPARADORAS PARA REPOSTERIA "PERGAMYN"

Pergamyn, Flächengewicht 40 g/m²,
im Spenderkarton

made of high-quality glassine, grammage
40 g/m², packed in dispenser boxes

#	↗ mm	→ mm		🛒 kg
113010	120	180	1/32	1
113011	180	250	1/16	1
113020	120	180	1/32	5
113022	250	370	1/8	5



DE	SAHNE-ABDECKPAPIERE "ZELLGLAS"
GB	CREAM COVERS "CELLOPHANE"
IT	CARTE ANTI-ADESIVE "CELOFAN"
ES	HOJAS SEPARADORAS PARA RESPOSTERIA "CELOFAN"

Zellglas, transparent,
Flächengewicht 35 g/m²

made of cellophane, transparent,
grammage 35 g/m²

#	↗ mm	→ mm		🛒 kg
114001	120	180	1/32	5
114002	180	250	1/16	5
114003	240	360	1/8	5



DE	FETTPAPIERHALTER
GB	DISPENSERS FOR GREASE-PROOF PAPERS
IT	SUPPORTI PER CARTA RESISTENTE AI GRASSI
ES	SOPORTE PARA PAPEL MANTEQUILLA

Material: Acryl, transparent,
selbstklebend

made of acryl, transparent,
self-mounting

#		↔ mm	🛒
172000	zur Ablage von DIN A 6-Papieren / storage and dispensing of paper sheets (ca. 125 x 187 mm)	130 x 190 x 65	1
172001	zur Ablage von DIN A 6-Papieren / storage and dispensing of paper sheets (ca. 125 x 187 mm)	190 x 135 x 65	1
172002	zur Ablage von DIN A 5-Papieren / storage and dispensing of paper sheets (ca. 187 x 250 mm)	255 x 185 x 65	1
172003	zur Ablage von DIN A 4-Papieren / storage and dispensing of paper sheets (ca. 250 x 375 mm)	380 x 260 x 65	1



15



DE	KREIDESTIFTE
GB	CHALKMARKER
IT	PENNE A GESSO LIQUIDO
ES	PENNA A GESSO LIQUIDO

Mit feuchtem Tuch und Wasser abwischbar.
Schreibt auf allen glatten Oberflächen
(Kreidetafeln, Glas, Spiegel, Kunststoff,
Metall, Fliesen, etc.)

Clean with water. Writes on all non porous
surfaces (chalkboards, glass, mirrors,
plastics, metals, tiles, etc.)



#		→ mm	
198900	○ weiß / white	5	1
198901	● blau / blue	5	1
198902	● gelb / yellow	5	1
198903	● grün / green	5	1
198904	● orange / orange	5	1
198905	● rot / red	5	1
198910	○ weiß / white	15	1
198911	● blau / blue	15	1
198912	● gelb / yellow	15	1
198913	● grün / green	15	1
198914	● orange / orange	15	1
198915	● rot / red	15	1



DE	BREZEL- ODER WURSTSTÄNDER
GB	PRETZEL- / SAUSAGE STAND
IT	SUPPORTO PER BREZEL- / O WURSTEL
ES	SUPPORTÀ BREZEL OU SAUCISSONS

Material: Edelstahl matt, stabile Ausführung,
8-armig, ideal für Brezeln oder Würste.
Einfache Selbstmontage.

Made of stainless steel, satin finish,
8-armed, ideal for pretzels or sausages.
Simple self-assembly.

#	↑ mm	Ø mm	
154812	500	210	1



Material: Holz, stabile Ausführung.
6-armig, ideal für Brezeln oder Würste.

Made of wood; 6-armed,
ideal for pretzels or sausages.

#	↑ mm	Ø mm	
120640	500	275	1



DE	SPUCK- UND NIESSCHUTZ
GB	PROTECTION
IT	PROTEZIONE
ES	PROTECCIÓN

Material: Acryl

Made of acrylic

#	↑ mm	Ø mm	
172401	500	370	1

DE	KÜHLPLATTEN
GB	COOLING TRAYS
IT	VASSOIO RAFFREDDANTE
ES	BANDEJA REFRIGERADA



Material: Edelstahl
 Integrierte Kühlelemente fest verschlossen
 Bei -20° ca. 4 Stunden gefrieren

Material: stainless steel
 Integrated cooling elements firmly closed
 Freeze at -20° for approx. 4 hours



#		↗ mm	→ mm	↑ mm	
281020	GN 1/1	530	325	45	1
281021	GN 1/2	325	265	45	1



NEW

DE	ALLZWECKZANGEN
GB	MULTI PURPOSE TONGS
IT	MULTIUSO PINZE
ES	PINZA MULTIUSOS

Material: Edelstahl, Griff Kunststoff schwarz Made of stainless steel, black plastic handle

#	↗ mm	
<input checked="" type="checkbox"/> 171040	230	1
<input checked="" type="checkbox"/> 171041	300	1
<input checked="" type="checkbox"/> 171042	400	1

Material: Edelstahl, Griff und Blatt aus Silikon, mit Verschleißmechanismus und Aufhänge-Öse

Made of stainless steel, handle and blade made of silicone, with closing mechanism and suspension eyelet



NEW

#	↗ mm	
<input checked="" type="checkbox"/> 171050	230	1
<input checked="" type="checkbox"/> 171051	300	1
<input checked="" type="checkbox"/> 171052	400	1



NEW

DE	TORTENHEBER
GB	CAKE SERVERS
IT	PALETTE PER TORTA
ES	PALETA PARA TORTAS

Material: Edelstahl

made of stainless steel



Art. 199030

#		↔ mm	↗ mm		
199030	aus einem Stück / in one piece	128 x 55	275	1	
199035	aus einem Stück, rechteckig / in one piece, rectangular	120 x 60	240	1	
199036	aus einem Stück, mit Spitze / in one piece, pointed	120 x 55	240	1	
<input checked="" type="checkbox"/> 149900	poliert / polished		Ø: 280	1	



Art. 199035 + 199036



Art. 149900

DE	ZANGEN
GB	TONGS
IT	PINZE
ES	PINZAS

Material: Edelstahl, aus einem Stück

made of stainless steel, in one piece

#		↔ mm		
<input checked="" type="checkbox"/> 171000	Gebäckzange, offen / pastry tongs, open	190 x 36	1	
<input checked="" type="checkbox"/> 171001	Gebäckzange, offen / pastry tongs, open	185 x 34	1	
<input checked="" type="checkbox"/> 171002	Gebäckzange, offen / pastry tongs, open	180 x 36	1	
<input checked="" type="checkbox"/> 171003	Gebäckzange, offen / pastry tongs, open	190 x 56	1	
<input checked="" type="checkbox"/> 171004	Tortenzange / cake tongs	230 x 20 x 53	1	
<input checked="" type="checkbox"/> 171005	Konfektzange, offen / pastry tongs, open	145 x 21	1	



Art. 171000

Art. 171001

Art. 171002

Art. 171003

Art. 171004

Art. 171005

DE	GRILL- ODER SERVIERZANGEN
GB	SAUSAGE TONGS
IT	PINZE PER BRACIE
ES	PINZA PARA BARBACOA

Material: Edelstahl made of stainless steel

#	↗ mm	
172415	220	1
172416	320	1



Art. 172415



Art. 172416

DE	WURSTZANGEN
GB	SAUSAGE TONGS
IT	PINZE PER BRACIE
ES	PINZA PARA BARBACOA

Material: Edelstahl, aus einem Stück geformt Greifende gewellt made of stainless steel, one piece corrugated ends

#		↔ mm	
172413	gebogen / bended	355 x 45 x 15	1
172414	gerade / straight	320 x 45 x 15	1



Art. 172413



Art. 172414

DE	PINZETTEN-ZANGEN
GB	PRECISION TONGS
IT	PINZE DI PRECISIONE
ES	PINZA DE PRECIÓNE RECTA

Material: Edelstahl made of stainless steel

#		↔ mm	
171020	gerade / straight	200	1
171030	gebogen / bended	200	1

Material: PPA, schwarz Made of PPA, black
 Hitzebeständig bis + 270 °C (* + 220 °C) Heat resistant up to + 270 °C (* + 220 °C)

#		↔ mm	
<input checked="" type="checkbox"/> 172370	Pinzette* / kitchen pincers*	305 x 18	1

Art. 172370



Art. 171030

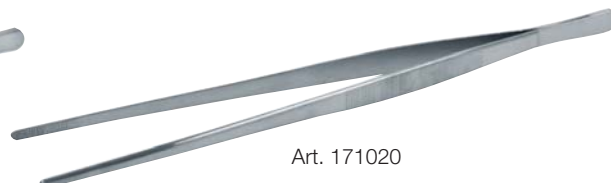

Art. 171020

DE	THEKENAUFSTELLER
GB	SHOW CASES
IT	VETRINE DA BANCO
ES	VITRINA

Material: Acryl

made of acrylic

#		↔ mm		
172600	für 1 Blech 200 x 600 mm / for 1 tray 200 x 600 mm	635 x 260 x 210	1	
172610	für 2 Bleche 200 x 600 mm / for 2 trays 200 x 600 mm	635 x 260 x 410	1	
172420	für 2 Bleche 200 x 600 mm / for 2 trays 200 x 600 mm	625 x 280 x 320	1	



Art. 172600



Art. 172610



Art. 172420



Material: Acryl, transparent
mit 3 Auslagetabletts aus Polycarbonat
mit hochklappbarem Entnahmedeckel

made of acrylic, transparent **with 3 trays**
 made of polycarbonate **with removable flip lid**

#	→ mm	↓ mm	↑ mm		
172630	340	250	340	1	



Material: Acryl, transparent **mit 2 Etagen und 2 Fronttüren**; Auslagetabletts aus Polycarbonat

made of acrylic, transparent **with 2 trays and 2 front doors**; trays made of polycarbonate

#	→ mm	↓ mm	↑ mm		
172640	450	310	370	1	

DE	THEKENPRÄSENTER
GB	SHOW CASES
IT	VETRINE DA BANCO
ES	VITRINA

Material: Acryl, transparent
mit hochklappbarem Entnahmedeckel
1 Platte GN1/1 (Polycarbonat)

made of acrylic, transparent with flip lid
1 tray GN 1/1 (polycarbonate)

#	→ mm	↓ mm	↑ mm	
172650	555	335	160	1

2-teilig (Platte aus Polycarbonat, Haube aus Acryl)

2 pieces (display tray made of polycarbonate and cover made of acrylic)

#	→ mm	↓ mm	↑ mm	
172670	435	280	140	1



DE	THEKENPRÄSENTER INKLUSIVE ROLLTOP-HAUBE
GB	SHOW CASE WITH ROLLTOP COVER
IT	VETRINA DA BANCO CON COPERCHIO "ROLLTOP"
ES	VITRINA PARA BARRA CON TAPA "ROLLTOP"

Rolltop-Haube aus Acryl, mit Griff
1 Platte GN1/1 (Polycarbonat)

rolltop cover, made of acrylic, with grip
1 tray GN 1/1 (polycarbonate)

#	→ mm	↓ mm	↑ mm	
172660	530	325	190	1



DE	ROLLTOP SET
GB	ROLLTOP SET
IT	PIATTO CON COPERCHIO "ROLLTOP"
ES	SOPORTE CON CAMPANA "ROLLTOP"

Platte rund, aus Edelstahl,
Haube aus Polycarbonat mit Griff

stainless steel tray, round, cover made of polycarbonate, with handle

#	Ø mm	
172680	430	1



15

DE	THEKENAUFSTELLER FÜR HYGIENISCHEN SCHUTZ
GB	COUNTER SHOW CASE FOR HYGIENIC PROTECTION
IT	VETRINA DA BANCO PER PROTEZIONE IGIENICA
ES	VITRINA PARA BARRA DE PROTECCION HIGIÉNICA

Material: Acryl, für Tablett und Bleche
195 x 600 mm oder 400 x 600 mm

made of acrylic, for trays 195 x 600 mm or
400 x 600 mm

#	→ mm	↓ mm	↑ mm	
172430	610	290	300	1



Schokolade
Chocolate
Cioccolato
Chocolate



DE	SCHOKOLADEN-FONTÄNE
GB	CHOCOLATE FOUNTAIN
IT	FONTANA CIOCCOLATO
ES	FUENTE CHOCOLATE

Material: Edelstahl	made of stainless steel
Gewicht: 5,5 kg	weight: 5,5 kg
Temperatur von 0 bis 80 °C einstellbar	temperatur adjustable between 0 and 80 °C
Bodendurchmesser 33 cm	bottom diameter: 33 cm
240 Volt	240 volt

#	↑ mm	⬇ kg	🔌	🛒	
255320	600	5 kg	150 W	1	



Temperatur von 0 bis 80 °C einstellbar	temperatur adjustable between 0 and 80 °C
Material: Edelstahl	made of stainless steel
Gewicht: 8 kg; 240 Volt; 50 Hz	weight: 8 kg; 240 volt; 50 Hz

#	↑ mm	⬇ kg	🔌	🛒	
255350	800	8	215 W	1	



DE	DOSIERGERÄT "PRALINENFIX D"
GB	DOSING METER / FILLING MACHINE "PRALINENFIX D"
IT	DOSIFICATRICE PER CIOCCOLATINI "PRALINENFIX D"
ES	DOSIFICADOR PARA RELLENAR BOMBONES

Ausführung "D"

Material: Edelstahl
 Zum schnellen, exakten und rationellen Füllen von Hohlkugeln. Dosierung erfolgt stufenlos Reihe für Reihe mit Hilfe von bis zu 7 verstellbaren Tüllen. Über 100 Füllungen pro Minute. Einfachste Reinigung und Handhabung, beheizte Kolbeneinheit. Speziell für Kuvertüre, Trüffelmasse, Ganache und ähnliche Massen.

Version "D"

Made of stainless steel.
 For fast, precise and efficient filling of hollow shells. Dosing row by row with 7 removable nozzles. More than 100 fillings per minute. Easy cleaning and handling, heated piston. Useable for chocolate, truffle, ganache and similar products.



CE

#	→ mm	↗ mm	↑ mm	⚖ kg	⚡ W	🔌 V	🛒	
450500	400	510	570	17	10 W	230 V	1	

DE	DOSIERGERÄT "PRALINENFIX B"
GB	DOSING METER / FILLING MACHINE "PRALINENFIX B"
IT	DOSIFICATRICE PER CIOCCOLATINI "PRALINENFIX B"
ES	DOSIFICADOR PARA RELLENAR PRALINES

Ausführung "B" –

speziell für Formen von **Chocolate World**
 Material: Edelstahl
 Zum schnellen, exakten und rationellen Füllen von Pralinenformen. Dosierung erfolgt stufenlos Reihe für Reihe mit Hilfe von bis zu 8 verstellbaren Tüllen. Über 100 Füllungen pro Minute. Einfachste Reinigung und Handhabung, beheizte Kolbeneinheit. Speziell für Kuvertüre, Trüffelmasse, Ganache und ähnliche Massen.

Version "B" –

especially for moulds from **Chocolate World**
 Made of stainless steel.
 For fast, precise and efficient filling of chocolate moulds. Dosing row by row with 8 removable nozzles. More than 100 fillings per minute. Easy cleaning and handling, heated piston. Useable for chocolate, truffle, ganache and similar products.



CE

16

#	→ mm	↗ mm	↑ mm	⚖ kg	⚡ W	🔌 V	🛒	
450510	400	510	570	17	10 W	230 V	1	

DE	ZUBEHÖR: LIKÖRTÜLLE
GB	EQUIPMENT: TRUFFLE TUBE
IT	ACCESSORI: BOCCHETTA LISCIA
ES	ACCESORIO: BOQUILLA LISA PARA RELLENAR BOMBONES

#	🛒
450520	1



DE	SCHOKOLADE-TEMPERIERGERÄTE
GB	CHOCOLATE DIPPING MACHINES
IT	TEMPERATRICI PER CIOCCOLATO
ES	TEMPERADOR DE CHOCOLATE



isoliertes Gehäuse aus Kunststoff,
Temperatur einstellbar (max. 60 °C)

insulated housing made of plastic,
adjustable temperature (max. 60 °C)

Kapazität: 1,5 Liter
inklusive Edelstahlbehälter und Deckel
Behälter: 15,5 x 14 x h 10 cm

capacity: 1,5 litres
including stainless steel container and lid
container: 15,5 x 14 x h 10 cm

#		↔ mm	
255250	220 V	230 x 260 x 125	1



Kapazität: 3 x 0,8 Liter
inklusive 3 Edelstahlbehälter und Deckel
Behälter: 15 x 8,3 x h 10 cm

capacity: 3 x 0,8 litres
including 3 stainless steel containers and lids
container: 15 x 8,3 x h 10 cm

#		↔ mm	
255260	220 V	440 x 300 x 135	1



Kapazität: 1 x 6,0 Liter
inklusive Edelstahlbehälter und Deckel
Behälter: 32 x 26,5 x 10 cm

capacity: 6,0 litres
including stainless steel containers and lid
container: 32 x 26,5 x 10 cm

#		↔ mm	
255280	220 V	400 x 330 x 135	1



Kapazität: 1 x 13,7 Liter
inklusive Edelstahlbehälter und Deckel
Behälter: 53 x 32,5 x 10 cm

capacity: 13,7 litres
including stainless steel container and lid
container: 53 x 32,5 x 10 cm

#		↔ mm	
255290	220 V	600 x 380 x 135	1

Kapazität: 4 x 1,5 Liter
inklusive 4 Edelstahlbehälter und Deckel
Behälter: 15,5 x 14 x h 10 cm

capacity: 4 x 1,5 litres
including 4 stainless steel containers and lids
container: 15,5 x 14 x h 10 cm

#		↔ mm	
255270	220 V	760 x 260 x 125	1



DE	SCHOKOLADE-TEMPERIERGERÄT
GB	CHOCOLATE DIPPING MACHINE
IT	TEMPERATRICE PER CIOCCOLATO
ES	TEMPERADOR DE CHOCOLATE

für Schokolade, Fondant, Kuvertüre, Saucen, Gelees ...
Material: Hochwertiger Edelstahl
Schmelzrate: 6 kg /13 lbs Schokolade in 2–3 Stunden

for chocolate, fondant, sauces, jellies ...
Body: High quality stainless steel
Melting rate: 6 kg /13 lbs chocolate in 2–3 hours

Temperaturbereich digital stufenlos einstellbar: 0°C–60°C / 32°F –140°F
Kapazität: 15l Wasser oder 18 kg / 33 lbs
Beheizung: Heißluft von allen 5 Seiten inklusive Edelstahlbehälter mit Deckel GN1/1
leicht ablesbare digitale Temperaturanzeige

range digitally adjustable: 0°C–60°C / 32°F –140°F
Capacity: 15 l water or 18 kg / 33 lbs
heating: hot air temperature from all 5 sides including stainless steel container with lid GN1/1
large digital display



CE

#		↔ mm	kg	
255400	500 W	675 x 345 x 375	18,0	1

Temperaturbereich: 20°C–60°C / 68°F –140°F
Kapazität: 5,5l Wasser oder 6 kg / 13 lbs Schokolade
Effiziente Beheizung: Luft & Direktkontakt von allen 5 Seiten
Temperatursensor: Innerhalb des Behälters für akkurate Messung

Temperature range: 20°C – 60°C / 68°F - 140°F
Capacity: 5,5 l water or 6kg / 13 lbs chocolate
Efficient heating: Air & Direct heating from all 5 sides
highest accuracy due to positioning inside the chocolate container

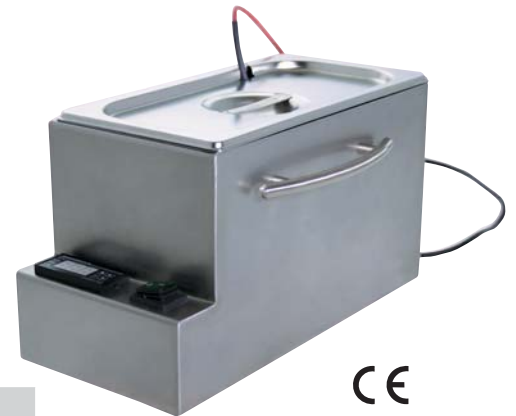

CE

#		↔ mm	kg	
255420	60W	380 x 180 x 210	4,6	1

DE	SPRÜHPISTOLE "ALEXO 500"
GB	SPRAY GUN "ALEXO 500"
IT	PISTOLA POLVERIZZATRICE ELETTRICA "ALEXO 500"
ES	PISTOLA PULVERIZADORA ELÉCTRICA "ALEXO 500"

Speziell für flüssige Schokolade (50 % Schokolade / 50 % Kakaobutter)
absolut lebensmitteleuglich, 29 – 40 °C;
Fördermenge: 120 – 200 ml/min
Viskosität: 20 – 28 DIN /Sek.
Inhalt: 550 ml; Gewicht: 1,06 kg
Nennleistung: 40W

Especially for liquid chocolate (50 % chocolate / 50 % cocoa butter)
100% food safe, useable from 29° to 40° C
output: 120 – 200 ml/min
viscosity: 20 – 28 DIN /sec.
volume: 550 ml; weight: 1,06 kg
power: 40W

wird mit Rundstrahldüse R6 geliefert

delivery includes circular jet spray R6

TIPP!
50% Schokolade
50% Kakaobutter
Temperatur: +29 /+40 °C

16

#		
153970	Sprühpistole "ALEXO 500" / Spray gun "ALEXO 500"	1
153975	Ersatzbehälter mit Deckel / container with lid	1
153976	Wärmeschutz / insulation sleeve	1



CE



DE	PRALINENTUNKGABEL-SET
GB	DIPPING-FORK SET
IT	SET FORCHETTINE PRALINERIA, INOX
ES	JUEGO DE TENEDORES

Material: Edelstahl
 Griff: Kunststoff (ABS), schwarz
 inklusive Kunststoffkoffer
 (L x B x H 240 x 195 x 45 mm)

made of stainless steel
 handle: plastic, black (ABS)
 with suitcase made of plastic
 (L x W x H 240 x 195 x 45 mm)

Set bestehend aus:
 je 1 Stück rund (14, 16, 18, 20 mm),
 Dreieck, Spirale, Tropfen, 2-, 3-, 4-zinkig

set consisting of 1 fork each:
 round (dia. 14, 16, 18, 20 mm) triangle, spiral
 and drop, 2-, 3-, 4-points

#			
199033	10-teilig / 10 pieces	1	



DE	PRALINENTUNKGABEL-SET GROSS
GB	DIPPING-FORK SET LARGE
IT	SET FORCHETTINE PRALINERIA GRANDE
ES	JUEGO DE TENEDORES GRANDE

Material: Edelstahl
 Griff: Kunststoff (ABS), schwarz

made of stainless steel
 handle: plastic, black (ABS)

Set bestehend aus:
 je 1 Stück rund (14, 16, 18, 20 mm),
 Dreieck, Spirale, Tropfen, 2-, 3-, 4-zinkig
 sowie Aufbewahrungs-Ständer aus Edel-
 stahl, aufklappbar, mit Anti-Rutsch-Füßen
 (L x B x H 275 x 200 x 225 mm)
 inklusive Kunststoffkoffer
 (L x B x H 305 x 260 x 50 mm)

set consisting of 1 fork each:
 round (dia. 14, 16, 18, 20 mm) triangle,
 spiral and drop, 2-, 3-, 4-points
 including rack made of stainless steel,
 foldable with non-slip feet
 (L x W x H 275 x 200 x 225 mm)
 including suitcase made of plastic
 (L x W x H 305 x 260 x 50 mm)



#			
199034	10-teilig + Ständer / 10 pieces + rack	1	

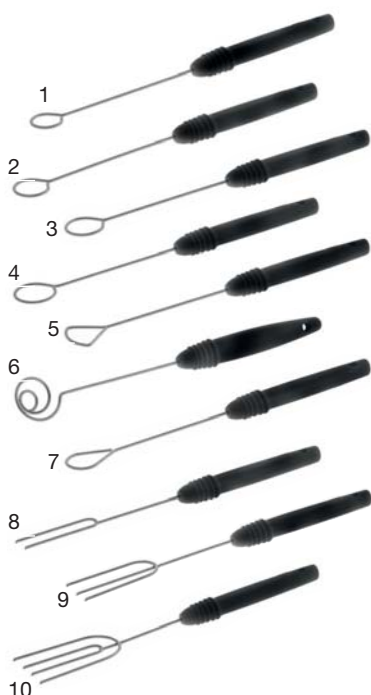

DE	PRALINENTUNKGABELN
GB	DIPPING-FORKS
IT	FORCHETTINE PRALINERIA
ES	TENEDORES PARA BOMBONES DE CHOCOLATE

Material: Edelstahl,
 Griff: Kunststoff (ABS), schwarz

made of stainless steel,
 handle: plastic, black (ABS)

#			mm		
199120	rund / round	1	14	1	
199121	rund / round	2	16	1	
199122	rund / round	3	18	1	
199123	rund / round	4	20	1	
199124	Dreieck / triangle	5		1	
199125	Spirale / spiral	6		1	
199126	Tropfen / drop	7		1	
199130	2-zinkig / 2-points	8		1	
199128	3-zinkig / 3-points	9		1	
199129	4-zinkig / 4-points	10		1	

DE	PRALINEN-VORRATSDOSE
GB	STORAGE BOX FOR CHOCOLATES
IT	CONTENITORI PER CIOCCOLATO
ES	CONTENEDORES PARA CHOCOLATE

Material: PS, glasklar, stapelbar made of PS, crystal clear

#	↗ mm	→ mm	↑ mm	
230030	335	225	73	1



DE	KUVERTÜRE- / SCHOKOLADE-ABSTECHEK
GB	CHOCOLATE GRATERS
IT	TAGLIAPASTA PER CIOCCOLATA
ES	CORTADORES PARA CHOCOLATE

Material: Edelstahl, Materialstärke: 0,8 mm made of stainless steel, thickness: 0,8 mm

#	↔ mm		
200610	120 x 115	flach / flat	1
200611	120 x 110	abgerundet / oblique	1



DE	SPACHTEL – EXTRA STABIL
GB	SPATULA – EXTRA STRONG
IT	RASCHIA - EXTRA STABILE
ES	ESPATULA PAR CHOCOLATE – MUY FUERTE

Material: Edelstahl, Griff Kunststoff, genietet, speziell für Schokolade made of stainless steel, plastic handle, with rivets, especially for chocolate

#	→ mm	
200710	180	1



DE	KASSEROLLE	
GB	SAUCEPAN	
IT	CASSERUOLA	
ES	CACEROLA	

Material: PP, weiß, mit geprägter Skala in Innenseite und zusätzl. blauem Skalendruck auf der Außenseite, bruchsicher und hygienisch, auch für Mikrowellengeräte geeignet
Volumen: 2,0 Liter made of PP, white, with inside scale and blue printed litre and ml scale outside, break resistant, suitable for microwave volume: 2,0 ltr.

#	↗ mm	Ø mm	↑ mm	
290200	335	190	120	1





DE	PRALINENSCHNEIDER "GITARRE"
GB	SLICING MACHINE "GUITAR"
IT	CHITARRE
ES	GUITARRA

zum Schneiden und Einteilen von Pralinen, Marzipan, Fruchtgelee, Gebäck etc.
 Material: Rahmen und Drähte Edelstahl, Sockel aus Edelstahl, inklusive 3 Rahmen und Spannvorrichtung

for cutting chocolate, marzipan, fruit jelly and similar products.
 Frames and wires made of stainless steel, base made of stainless steel, including 3 frames and fixture

#		↔ mm	⚖ kg	🛒
255000	10 mm, 20 mm und 30 mm	600 x 340	23	1
256000	22,5 mm, 30 mm und 37,5 mm	360 x 360	33	1
256100	22,5 mm, 30 mm und 37,5 mm (doppelt/double)	360 x 360	38	1
256200	22 mm	440 x 320	16,5	1
256300	22,5 mm, 30 mm und 45 mm	390 x 450	26,5	1



Art.-Nr. 255000



Art.-Nr. 256000



Art.-Nr. 256100



Art.-Nr. 256200



Art.-Nr. 256300



DE	SCHOKOLADEN-FORMEN AUS SILIKON
GB	CHOCOLATE MOULDS MADE OF SILICONE
IT	STAMPI IN SILICONE PER CIOCCOLATO
ES	MOLDES EN SILICONA PARA CHOCOLATE

Material: Silikon, braun
-60°C bis +230°C

made of silicone, brown
-60°C to +230°C

#		Formen/ moulds	↔ mm	 ml	
115400	Herz/heart	15	30 x 22 x 25	10 / 150	
115401	Kubus/cube	15	26 x 26 / 18	10 / 150	
115403	Rund/round	15	∅ 28 / 18	10 / 150	
115405	Praline/praline	15	∅ 30 x 18	15 / 150	
115406	Blumen/flowers	15	30 x 30 x 15	9 / 135	
115407	Rechteck/jack	14	37 x 20 x 20	8 / 112	
115409	Tafel/tablette	12	38 x 28 x 4,5	3,5 / 42	
115412	Figur/figure	12	33 x 34 x 17	8 / 96	
115416	Gugelhupf/gugelhopf	15	∅ 28 / 15	6,5 / 97,5	
115417	Kegel/cone	15	∅ 26 / 28	7,5 / 112,5	
115418	Macaron/macaron	15	∅ 26 / 28	7,5 / 112,5	

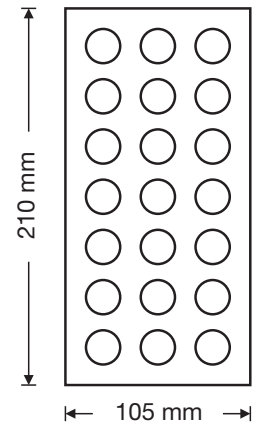

Art.-Nr. 115400



Art.-Nr. 115401



Art.-Nr. 115403



Art.-Nr. 115405



Art.-Nr. 115406



Art.-Nr. 115407



Art.-Nr. 115409



Art.-Nr. 115412



Art.-Nr. 115416



Art.-Nr. 115417



Art.-Nr. 115418



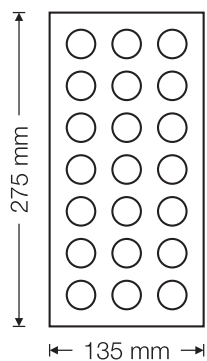
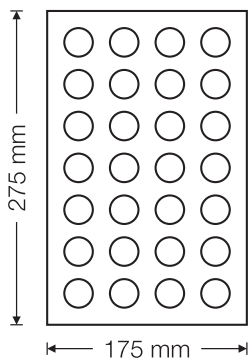

DE	SCHOKOLADENFORMEN
GB	CHOCOLATE MOULDS
IT	STAMPI PER CIOCCOLATO
ES	MOLDES PARA CHOCOLATE

Das Gewicht wurde auf der Grundlage von Vollmilch-Schokolade bestimmt und kann je nach Schokoladensorte, der Füllung sowie der Gießtechnik, Abweichungen verzeichnen.
 Material: Polycarbonat
 (Kunststoff), sehr robust und stoßfest.

Il peso è determinato in base al cioccolato a latte e può subire variazioni secondo il tipo di cioccolato, il ripieno e la tecnica di fusione. Materiale: policarbonato (plastica), extra robusta e resistente agli urti.

The weight is based on a moulding with solid milk chocolate and may depend on your chocolate, filling and way of moulding.
 Material: polycarbonate (plastic), very robust and shockproof.

El peso queda determinado a base de chocolate con leche entera y puede ser distinto según el tipo de chocolate, relleno y técnica de moldeo.
 Material: policarbonato (plástico), muy robusto y resistente a los choques.



DE	ZUBEHÖR FÜR DOPPELFORMEN
GB	ACCESSORIES FOR DOUBLE MOULDS
IT	ACCESSORI PER STAMPI DOPPI
ES	ACCESORIOS PARA MOLDES DOBLES

KLAMMER, Kunststoff
CLIP, made of plastic

Art.-Nr./code 429998

VERBINDUNGSSTIFT, Edelstahl
CENTER SCREW, stainless steel

Art.-Nr./code 429999

DE	VALENTIN
GB	VALENTINE
IT	SAN VALENTINO
ES	SAN VALENTIN



#	421012
↔ ↑ mm	275 x 135 x 24
Stückzahl	3 x 8
↔ mm	31 x 29 x 19
Stk./g	13



#	421023
↔ ↑ mm	275 x 135 x 24
Stückzahl	3 x 8
↔ mm	30 x 22 x 20
Stk./g	11



#	421214
↔ ↑ mm	275 x 135 x 24
Stückzahl	3 x 8
↔ mm	31 x 35 x 18
Stk./g	15



# - Doppelform	421280
↔ ↑ mm	275 x 135 x 24
Stückzahl	3 x 8
↔ mm	30 x 26 x 9
Stk./g	2 x 5



#	421296
↔ ↑ mm	275 x 135 x 24
Stückzahl	3 x 7
↔ mm	49 x 26 x 17
Stk./g	15



#	421297
↔ ↑ mm	275 x 135 x 24
Stückzahl	1 x 7
↔ mm	102 x 36 x 19
Stk./g	41



#	421417
↔ ↑ mm	275 x 135 x 24
Stückzahl	3 x 8
↔ mm	33 x 31 x 15
Stk./g	11



# - Doppelform	421513
↔ ↑ mm	275 x 135 x 24
Stückzahl	3 x 7
↔ mm	35 x 33 x 11
Stk./g	2 x 8,6



#	421517
↔ ↑ mm	275 x 135 x 24
Stückzahl	3 x 8
↔ mm	45 x 27 x 17
Stk./g	11



#	421526
↔ ↑ mm	275 x 135 x 24
Stückzahl	4 x 7
↔ mm	28 x 22,6 x 16
Stk./g	8,6



#	421726
↔ ↑ mm	275 x 135 x 24
Stückzahl	3 x 12 fig.
↔ mm	32 x 15,5 x 8
Stk./g	2,5



#	421937
↔ ↑ mm	275 x 135 x 24
Stückzahl	3 x 7
↔ mm	42 x 21,5 x 15
Stk./g	8,5

DE	VALENTIN
GB	VALENTIN
IT	VALENTIN
ES	VALENTIN



NEW

# - Doppelform	421145
↔ ↑ mm	275 x 135 x 24
Stückzahl	2 x 4
↔ mm	65 x 57 x 14
Stk./g	35



NEW

# - Doppelform	421146
↔ ↑ mm	275 x 135 x 24
Stückzahl	1 x 5
↔ mm	80 x 69 x 16
Stk./g	68



NEW

#	421147
↔ ↑ mm	275 x 135 x 24
Stückzahl	1 x 5
↔ mm	95 x 83 x 19
Stk./g	118



NEW

#	421148
↔ ↑ mm	275 x 135 x 26
Stückzahl	1 x 2
↔ mm	119 x 104 x 23
Stk./g	205



NEW

#	421216
↔ ↑ mm	275 x 135 x 24
Stückzahl	3 x 9
↔ mm	30 x 22 x 20
Stk./g	11



NEW

#	421218
↔ ↑ mm	275 x 175 x 24
Stückzahl	4 x 7
↔ mm	30 x 36 x 19
Stk./g	14



NEW

#	421576
↔ ↑ mm	275 x 135 x 24
Stückzahl	3 x 7 / 3 fig.
↔ mm	29 x 34,5 x 17
Stk./g	12



NEW

#	421744
↔ ↑ mm	275 x 135 x 24
Stückzahl	3 x 8
↔ mm	33 x 22,5 x 16
Stk./g	10,5



NEW

#	422121
↔ ↑ mm	275 x 175 x 24
Stückzahl	1 x 2
↔ mm	145 x 126 x 20
Stk./g	305



NEW

#	422122
↔ ↑ mm	275 x 175 x 24
Stückzahl	1 x 2
↔ mm	145 x 126 x 20
Stk./g	300



NEW

#	421892
↔ ↑ mm	275 x 135 x 24
Stückzahl	3 x 6
↔ mm	32,9 x 32,9 x 9,9
Stk./g	5,0



NEW

#	421893
↔ ↑ mm	275 x 135 x 24
Stückzahl	3 x 7
↔ mm	43 x 23 x 13
Stk./g	8,2

DE	OSTERN
GB	EASTER
IT	PASQUA
ES	PASCUA



# - Doppelform	421053
↔ ↑ mm	275 x 135 x 24
Stückzahl	4 x 8
↔ mm	32 x 23 x 11
Stk./g	2 x 5



# - Doppelform	421266
↔ ↑ mm	275 x 135 x 24
Stückzahl	3 x 8
↔ mm	35 x 23 x 12
Stk./g	2 x 6



# - Doppelform	421317
↔ ↑ mm	275 x 135 x 24
Stückzahl	3 x 8
↔ mm	43 x 30 x 14
Stk./g	2 x 12



#	421362
↔ ↑ mm	275 x 135 x 24
Stückzahl	3 x 8
↔ mm	38 x 25 x 14
Stk./g	12



# - Doppelform	421383
↔ ↑ mm	275 x 135 x 24
Stückzahl	3 x 8
↔ mm	42 x 27 x 14
Stk./g	2 x 11



# - Doppelform	421516
↔ ↑ mm	275 x 135 x 24
Stückzahl	5 x 7
↔ mm	29 x 21 x 10
Stk./g	2 x 4



# - Doppelform	421537
↔ ↑ mm	275 x 135 x 24
Stückzahl	3 x 9
↔ mm	35 x 23 x 12
Stk./g	2 x 6



# - Doppelform	421050
↔ ↑ mm	275 x 135 x 24
Stückzahl	5 x 7
↔ mm	29 x 21 x 10
Stk./g	4



# - Doppelform	421251
↔ ↑ mm	275 x 135 x 28
Stückzahl	2 x 4
↔ mm	70 x 47 x 25
Stk./g	54



# - Doppelform	421252
↔ ↑ mm	275 x 135 x 32
Stückzahl	2 x 3
↔ mm	81 x 54 x 30
Stk./g	83



# - Doppelform	421253
↔ ↑ mm	275 x 135 x 32
Stückzahl	2 x 3
↔ mm	86 x 58 x 30
Stk./g	97



# - Doppelform	421254
↔ ↑ mm	275 x 135 x 35
Stückzahl	2 x 2
↔ mm	100 x 65 x 35
Stk./g	135

DE	OSTERN
GB	OSTERN
IT	OSTERN
ES	OSTERN



NEW

# - Doppelform	421255
↔ ↑ mm	275 x 135 x 40
Stückzahl	1 x 3
↔ mm	118 x 77 x 40
Stk./g	227



NEW

# - Doppelform	421358
↔ ↑ mm	275 x 135 x 24
Stückzahl	3 x 9
↔ mm	29 x 23 x 11
Stk./g	4,5



NEW

# - Doppelform	421582
↔ ↑ mm	275 x 135 x 24
Stückzahl	3 x 8
↔ mm	33 x 23 x 12
Stk./g	5,0



NEW

# - Doppelform	421640
↔ ↑ mm	275 x 135 x 24
Stückzahl	3 x 6
↔ mm	34 x 35 x 14
Stk./g	12



NEW

#	421641
↔ ↑ mm	275 x 135 x 24
Stückzahl	3 x 7 / 7 fig.
↔ mm	31 x 31 x 9
Stk./g	9,0



NEW

# - Doppelform	421656
↔ ↑ mm	275 x 135 x 24
Stückzahl	3 x 6
↔ mm	38 x 27,5 x 15
Stk./g	7,0



NEW

# - Doppelform	421664
↔ ↑ mm	275 x 135 x 30
Stückzahl	3 x 4
↔ mm	62 x 41,5 x 23
Stk./g	35



NEW

#	421739
↔ ↑ mm	275 x 135 x 24
Stückzahl	1 x 4
↔ mm	45,5 x 99,5 x 19
Stk./g	49



NEW

#	421786
↔ ↑ mm	275 x 135 x 24
Stückzahl	3 x 8
↔ mm	33 x 26,5 x 13
Stk./g	13



NEW

#	421873
↔ ↑ mm	275 x 135 x 40
Stückzahl	2 x 3
↔ mm	72 x 55 x 35
Stk./g	46,6



NEW

#	421888
↔ ↑ mm	275 x 135 x 35
Stückzahl	2 x 3
↔ mm	86,5 x 56,5 x 25,5
Stk./g	69,7



NEW

#	421889
↔ ↑ mm	275 x 135 x 40
Stückzahl	2 x 3
↔ mm	86,8 x 56,4 x 33,4
Stk./g	86,8

DE	OSTERN
GB	EASTER
IT	PASQUA
ES	PASCUA



NEW

# - Doppelform	421891
←↑ mm	275 x 135 x 24
Stückzahl	3 x 8
↔ mm	33 x 23 x 11
Stk./g	2 x 5,5



NEW

# - Doppelform	421554
←↑ mm	275 x 135 x 24
Stückzahl	4 x 8
↔ mm	32 x 22 x 24
Stk./g	5,0



NEW

# - Doppelform	421907
←↑ mm	275 x 135 x 24
Stückzahl	5 x 7
↔ mm	29 x 21 x 10
Stk./g	2 x 4



NEW

# - Doppelform	421910
←↑ mm	275 x 135 x 35
Stückzahl	2 x 3
↔ mm	86,5 x 56 x 30
Stk./g	2 x 94,5



NEW

# - Doppelform	422395
←↑ mm	275 x 175 x 24
Stückzahl	4 x 8 / 3 Fig.
↔ mm	32,5 x 22,5 x 12
Stk./g	2 x 5

DE	WEIHNACHTEN UND NEUJAHR
GB	CHRISTMAS AND NEW YEAR
IT	NATALE E CAPODANNO
ES	NAVIDAD Y AÑO NUEVO



#	421209
←↑ mm	275 x 135 x 24
Stückzahl	2 x 7
↔ mm	57 x 32 x 7
Stk./g	5



# - Doppelform	421635
←↑ mm	275 x 135 x 24
Stückzahl	2 x 4
↔ mm	48 x 40 x 18
Stk./g	2 x 16



# - Doppelform	422037
←↑ mm	275 x 175 x 24
Stückzahl	2 x 9
↔ mm	66 x 23 x 12
Stk./g	2 x 11

DE	WEIHNACHTEN UND NEUJAHR
GB	CHRISTMAS AND NEW YEAR
IT	NATALE E CAPODANNO
ES	NAVIDAD Y AÑO NUEVO



# - Doppelform	422038
↔↑ mm	275 x 175 x 24
Stückzahl	2 x 6
↔ mm	90 x 24 x 12
Stk./g	2 x 15



NEW

#	421078
↔↑ mm	275 x 135 x 24
Stückzahl	4 x 3
↔ mm	67 x 29 x 8
Stk./g	9,5



NEW

#	421079
↔↑ mm	275 x 135 x 24
Stückzahl	1 x 6
↔ mm	110 x 36 x 10
Stk./g	34



NEW

#	421302
↔↑ mm	275 x 135 x 24
Stückzahl	3 x 7
↔ mm	40 x 30 x 15
Stk./g	12



NEW

#	421333
↔↑ mm	275 x 135 x 24
Stückzahl	3 x 7
↔ mm	38 x 30 x 20
Stk./g	15



NEW

#	421406
↔↑ mm	275 x 135 x 24
Stückzahl	3 x 7
↔ mm	38 x 30 x 20
Stk./g	15



NEW

#	421439
↔↑ mm	275 x 135 x 24
Stückzahl	3 x 4
↔ mm	57 x 32 x 10
Stk./g	7,0



NEW

#	421655
↔↑ mm	275 x 135 x 24
Stückzahl	1 x 6
↔ mm	100 x 35 x 13
Stk./g	30



NEW

#	421868
↔↑ mm	275 x 135 x 24
Stückzahl	1 x 4
↔ mm	100 x 59 x 21
Stk./g	104,5



NEW

#	421869
↔↑ mm	275 x 135 x 24
Stückzahl	3 x 8
↔ mm	34,5 x 25 x 18
Stk./g	10,5



NEW

#	421870
↔↑ mm	275 x 135 x 24
Stückzahl	3 x 7
↔ mm	40 x 25 x 18
Stk./g	10,5



NEW

#	421878
↔↑ mm	275 x 135 x 24
Stückzahl	1 x 4
↔ mm	80 x 59
Stk./g	-

DE	NATUR
GB	NATURE
IT	NATURA
ES	NATURALEZA



#	421033
↙↑ mm	275 x 135 x 24
Stückzahl	3 x 7
↔ mm	Ø 34 x 20
Stk./g	18



#	421048
↙↑ mm	275 x 135 x 24
Stückzahl	2 x 5 / 5 Fig.
↔ mm	Ø 43 x 5
Stk./g	6



#	421058
↙↑ mm	275 x 135 x 24
Stückzahl	3 x 7
↔ mm	Ø 28 x 20
Stk./g	12



#	421134
↙↑ mm	275 x 135 x 24
Stückzahl	3 x 8
↔ mm	33 x 24 x 20
Stk./g	13



#	421519
↙↑ mm	275 x 135 x 24
Stückzahl	3 x 7
↔ mm	33 x 27 x 17
Stk./g	11,5



#	421637
↙↑ mm	275 x 135 x 24
Stückzahl	3 x 8
↔ mm	26 x 26 x 16
Stk./g	9,6



NEW

#	421826
↙↑ mm	275 x 135 x 24
Stückzahl	3 x 6
↔ mm	37,5 x 34,5 x 6
Stk./g	5,0



NEW

#	421830
↙↑ mm	275 x 135 x 24
Stückzahl	3 x 7
↔ mm	44,5 x 26 x 13,5
Stk./g	10



NEW

# - Doppelform	421197
↙↑ mm	275 x 135 x 24
Stückzahl	3 x 7
↔ mm	30 x 30 x 15
Stk./g	8,0



NEW

#	421568
↙↑ mm	275 x 135 x 24
Stückzahl	4 x 8
↔ mm	25 x 24,5 x 18
Stk./g	8,0

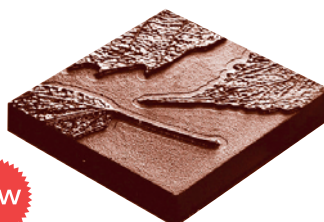

NEW

#	421669
↙↑ mm	275 x 135 x 24
Stückzahl	2 x 5
↔ mm	41 x 41 x 7
Stk./g	13



NEW

# - Doppelform	421917
↙↑ mm	275 x 135 x 24
Stückzahl	3 x 7
↔ mm	30 x 30 x 10
Stk./g	2 x 5

DE	ÜBERZIEHPRALINEN
GB	ENROBED CHOCOLATES
IT	CIOCCOLATINI RICOPERTI
ES	BOMBONES BAÑADOS



#	421037
↔ ↑ mm	275 x 135 x 24
Stückzahl	3 x 7
↔ mm	∅ 35 x 21
Stk./g	16



#	421219
↔ ↑ mm	275 x 135 x 24
Stückzahl	3 x 8
↔ mm	27 x 22 x 15
Stk./g	11



#	421289
↔ ↑ mm	275 x 135 x 24
Stückzahl	3 x 8
↔ mm	25 x 25 x 20
Stk./g	11



#	421290
↔ ↑ mm	275 x 135 x 24
Stückzahl	3 x 8
↔ mm	∅ 29 x 17
Stk./g	11



#	421300
↔ ↑ mm	275 x 135 x 24
Stückzahl	3 x 8
↔ mm	33 x 22 x 18
Stk./g	11



#	421384
↔ ↑ mm	275 x 135 x 24
Stückzahl	3 x 8
↔ mm	36 x 25 x 19
Stk./g	16



#	421393
↔ ↑ mm	275 x 135 x 24
Stückzahl	3 x 8
↔ mm	36 x 26 x 18
Stk./g	18



#	421561
↔ ↑ mm	275 x 135 x 24
Stückzahl	3 x 7 fig.
↔ mm	27,5 x 27,5 x 14,9
Stk./g	7



#	422432
↔ ↑ mm	275 x 175 x 24
Stückzahl	4 x 8
↔ mm	34,5 x 25,7 x 17
Stk./g	14

DE	HERBST UND NÜSSE
GB	AUTUMN AND NUTS
IT	AUTUNNO E NOCI
ES	OTONO Y NUECES



#	421015
↙↑ mm	275 x 135 x 24
Stückzahl	3 x 8
↔ mm	38 x 29 x 18
Stk./g	13



#	421027
↙↑ mm	275 x 135 x 24
Stückzahl	3 x 8
↔ mm	37 x 27 x 18
Stk./g	12



#	421046
↙↑ mm	275 x 135 x 24
Stückzahl	3 x 7
↔ mm	37 x 31 x 16
Stk./g	14



#	421089
↙↑ mm	275 x 135 x 24
Stückzahl	3 x 8
↔ mm	37 x 31 x 20
Stk./g	16



# – Doppelform	421093
↙↑ mm	275 x 135 x 24
Stückzahl	3 x 8
↔ mm	37 x 29 x 14
Stk./g	2 x 7,5



#	421095
↙↑ mm	275 x 135 x 24
Stückzahl	3 x 5
↔ mm	49 x 36 x 13
Stk./g	17



#	421104
↙↑ mm	275 x 135 x 24
Stückzahl	3 x 7
↔ mm	40 x 35 x 10
Stk./g	10



#	421191
↙↑ mm	275 x 135 x 24
Stückzahl	2 x 11
↔ mm	47 x 19 x 17
Stk./g	13



#	421226
↙↑ mm	275 x 135 x 24
Stückzahl	3 x 8
↔ mm	29 x 28 x 17
Stk./g	12



#	421483
↙↑ mm	275 x 135 x 24
Stückzahl	4 x 5
↔ mm	49 x 28 x 15
Stk./g	21



# – Doppelform	421498
↙↑ mm	275 x 135 x 24
Stückzahl	4 x 4
↔ mm	58 x 21 x 9
Stk./g	2 x 6



#	422343
↙↑ mm	275 x 175 x 24
Stückzahl	3 x 6
↔ mm	77 x 18 x 19
Stk./g	27

DE	KAFFEEBOHNEN
GB	COFFEE BEANS
IT	CHICCHI DI CAFFÈ
ES	GRANO DE CAFÉ



#	421019
↙↑ mm	275 x 135 x 24
Stückzahl	4 x 9
↔ mm	25 x 25 x 25
Stk./g	14



#	421327
↙↑ mm	275 x 135 x 24
Stückzahl	3 x 8
↔ mm	36 x 24 x 16
Stk./g	11



#	421529
↙↑ mm	275 x 135 x 24
Stückzahl	4 x 7
↔ mm	33 x 21,7 x 14,5
Stk./g	8,6



# – Doppelform	422370
↙↑ mm	275 x 175 x 24
Stückzahl	3 x 4
↔ mm	73,7 x 38 x 20
Stk./g	30,25



#	421558
↙↑ mm	275 x 135 x 24
Stückzahl	2 x 8
↔ mm	50 x 24 x 12
Stk./g	8,0



#	421540
↙↑ mm	275 x 135 x 24
Stückzahl	3 x 7
↔ mm	34 x 34 x 5
Stk./g	4,35



#	422431
↙↑ mm	275 x 175 x 24
Stückzahl	4 x 7
↔ mm	34,5 x 34,5 x 4,5
Stk./g	4,5



#	421877
↙↑ mm	275 x 135 x 24
Stückzahl	3 x 7
↔ mm	27 x 27 x 16
Stk./g	12



#	421880
↙↑ mm	275 x 135 x 24
Stückzahl	3 x 8
↔ mm	20 x 20 x 19
Stk./g	6,9



#	421901
↙↑ mm	275 x 135 x 24
Stückzahl	3 x 7
↔ mm	31,5 x 31,5 x 5
Stk./g	5



# – Doppelform	421919
↙↑ mm	275 x 135 x 24
Stückzahl	7 x 9
↔ mm	19 x 9 x 4
Stk./g	2 x 0,60

DE	FIGUREN
GB	FIGURES
IT	FIGURE
ES	FIGURAS



#	421006
↙↑ mm	275 x 135 x 24
Stückzahl	3 x 8
↔ mm	38 x 27 x 16
Stk./g	15



#	421411
↙↑ mm	275 x 135 x 24
Stückzahl	3 x 5
↔ mm	50 x 35 x 12
Stk./g	12



#	421457
↙↑ mm	275 x 135 x 24
Stückzahl	3 x 4
↔ mm	61 x 31 x 19
Stk./g	23



# – Doppelform	421666
↙↑ mm	275 x 135 x 24
Stückzahl	3 x 8
↔ mm	26 x 38 x 27
Stk./g	12



# – Doppelform	421727
↙↑ mm	275 x 135 x 24
Stückzahl	3 x 6 fig.
↔ mm	37,5 x 32 x 12,5
Stk./g	2 x 7,5

NEW



#	421874
↙↑ mm	275 x 135 x 24
Stückzahl	3 x 6
↔ mm	36,5 x 34
Stk./g	16,5



NEW

#	421129
↙↑ mm	275 x 135 x 24
Stückzahl	2 x 5
↔ mm	66 x 45 x 14
Stk./g	20



NEW

#	421746
↙↑ mm	275 x 135 x 24
Stückzahl	3 x 5 / 5 fig.
↔ mm	–
Stk./g	12,0

NEW



# – Doppelform	421931
↙↑ mm	275 x 135 x 24
Stückzahl	1 x 4
↔ mm	80 x 68,6 x 16,53
Stk./g	–



NEW

# – Doppelform	421933
↙↑ mm	275 x 135 x 24
Stückzahl	2 x 6
↔ mm	45 x 39 x 9,3
Stk./g	2 x 6



NEW

#	421934
↙↑ mm	275 x 135 x 24
Stückzahl	1 x 4
↔ mm	unterschiedlich
Stk./g	20

NEW



# – Doppelform	421938
↙↑ mm	275 x 135 x 24
Stückzahl	2 x 7
↔ mm	37,5 x 30 x 12
Stk./g	2 x 7,5

DE	HOBBYS
GB	HOBBYS
IT	HOBBY
ES	HOBBY



# - Doppelform	421423
↔ ↑ mm	275 x 135 x 24
Stückzahl	2 x 4
↔ mm	Ø 60
Stk./g	2 x 35



# - Doppelform	421428
↔ ↑ mm	275 x 135 x 24
Stückzahl	4 x 8
↔ mm	Ø 26
Stk./g	2 x 6



# - Doppelform	421443
↔ ↑ mm	275 x 135 x 24
Stückzahl	3 x 8
↔ mm	Ø 30
Stk./g	2 x 8,5



#	421493
↔ ↑ mm	275 x 135 x 24
Stückzahl	4 x 8
↔ mm	Ø 28 x 16
Stk./g	10



# - Doppelform	421674
↔ ↑ mm	275 x 135 x 24
Stückzahl	2 x 4 fig.
↔ mm	61 x 45 x 10
Stk./g	2 x 10



NEW

# - Doppelform	421224
↔ ↑ mm	275 x 135 x 24
Stückzahl	3 x 9
↔ mm	30 x 24 x 11
Stk./g	-

DE	BUCHSTABEN
GB	LETTERS
IT	LETTERE ALFABETICHE
ES	LETRAS



#	421628
↔ ↑ mm	275 x 135 x 24
Stückzahl	3 x 8 24 fig.
↔ mm	26 x 26 x 18,50
Stk./g	12



#	421643
↔ ↑ mm	275 x 135 x 24
Stückzahl	3 x 8
↔ mm	29 x 25 x 9
Stk./g	-

DE	KEKSE
GB	BISCUITS
IT	BISCOTTINI
ES	SORPRESAS



#	421357
↔ ↑ mm	275 x 135 x 24
Stückzahl	3 x 8
↔ mm	Ø 30 x 7
Stk./g	5



#	421456
↔ ↑ mm	275 x 135 x 24
Stückzahl	3 x 6
↔ mm	Ø 39 x 5
Stk./g	9



#	422018
↔ ↑ mm	275 x 175 x 24
Stückzahl	2 x 6
↔ mm	78 x 38 x 4
Stk./g	9



#	422054
↔ ↑ mm	275 x 175 x 24
Stückzahl	4 x 6
↔ mm	Ø 36 x 4
Stk./g	5

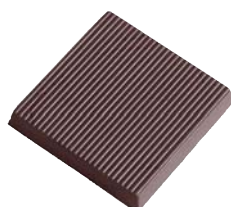

#	422360
↔ ↑ mm	275 x 175 x 24
Stückzahl	3 x 6
↔ mm	33 x 33 x 5
Stk./g	6



#	421597
↔ ↑ mm	275 x 135 x 24
Stückzahl	2 x 6
↔ mm	36 x 28 x 9
Stk./g	6,0



#	421321
↔ ↑ mm	275 x 135 x 24
Stückzahl	3 x 8
↔ mm	27 x 6
Stk./g	3,0



#	421795
↔ ↑ mm	275 x 135 x 24
Stückzahl	3 x 8
↔ mm	25 x 25 x 7
Stk./g	3,5



#	421847
↔ ↑ mm	275 x 135 x 24
Stückzahl	3 x 7
↔ mm	35 x 35 x 9
Stk./g	6,0



#	421865
↔ ↑ mm	275 x 135 x 24
Stückzahl	3 x 8
↔ mm	25,5 x 25,5 x 15
Stk./g	9,0



#	421853
↔ ↑ mm	275 x 135 x 24
Stückzahl	3 x 7
↔ mm	28 x 28 x 4,6
Stk./g	4,4

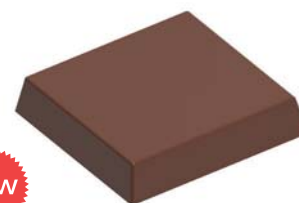

#	421887
↔ ↑ mm	275 x 135 x 24
Stückzahl	3 x 7
↔ mm	30,5 x 30,5 x 5,6
Stk./g	5,7

DE	FANTASIE
GB	FANTASY
IT	FANTASIA
ES	FANTASÍA



#	421024
↔ ↑ mm	275 x 135 x 24
Stückzahl	3 x 7
↔ mm	31 x 31 x 20
Stk./g	15



#	421025
↔ ↑ mm	275 x 135 x 24
Stückzahl	3 x 8
↔ mm	36 x 22 x 20
Stk./g	15



#	421031
↔ ↑ mm	275 x 135 x 24
Stückzahl	3 x 8
↔ mm	37 x 23 x 20
Stk./g	17



#	421036
↔ ↑ mm	275 x 135 x 24
Stückzahl	3 x 8
↔ mm	29 x 29 x 20
Stk./g	17



#	421045
↔ ↑ mm	275 x 135 x 24
Stückzahl	3 x 8
↔ mm	30 x 27 x 19
Stk./g	13



#	421081
↔ ↑ mm	275 x 135 x 24
Stückzahl	3 x 7
↔ mm	Ø 32 x 28
Stk./g	22



#	421082
↔ ↑ mm	275 x 135 x 24
Stückzahl	3 x 10
↔ mm	35 x 20 x 17
Stk./g	14



#	421094
↔ ↑ mm	275 x 135 x 24
Stückzahl	3 x 8
↔ mm	Ø 31 x 22
Stk./g	15



#	421189
↔ ↑ mm	275 x 135 x 24
Stückzahl	3 x 8
↔ mm	30 x 27 x 16
Stk./g	12



#	421225
↔ ↑ mm	275 x 135 x 24
Stückzahl	3 x 8
↔ mm	33 x 25 x 21
Stk./g	14



#	421263
↔ ↑ mm	275 x 135 x 24
Stückzahl	3 x 7
↔ mm	37 x 27 x 15
Stk./g	15



#	421301
↔ ↑ mm	275 x 135 x 24
Stückzahl	3 x 8
↔ mm	Ø 30 x 16
Stk./g	10

DE	FANTASIE
GB	FANTASY
IT	FANTASIA
ES	FANTASÍA



#	421369
↔ ↑ mm	275 x 135 x 24
Stückzahl	3 x 7
↔ mm	40 x 29 x 20
Stk./g	17



#	421397
↔ ↑ mm	275 x 135 x 24
Stückzahl	3 x 8
↔ mm	29 x 25 x 19
Stk./g	13



#	421533
↔ ↑ mm	275 x 135 x 24
Stückzahl	1 x 10
↔ mm	11,5 x 24 x 13
Stk./g	8,55



#	421638
↔ ↑ mm	275 x 135 x 24
Stückzahl	2 x 7
↔ mm	48 x 29 x 15
Stk./g	9,8

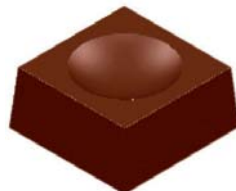

#	421647
↔ ↑ mm	275 x 135 x 24
Stückzahl	3 x 8
↔ mm	26 x 26 x 12
Stk./g	9

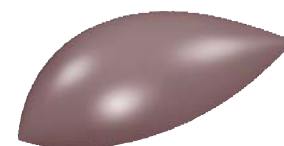

# – Doppelform	421673
↔ ↑ mm	275 x 135 x 24
Stückzahl	2 x 8 fig.
↔ mm	45,5 x 25 x 12,5
Stk./g	2 x 10

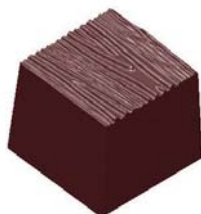

#	421676
↔ ↑ mm	275 x 135 x 24
Stückzahl	4 x 8 fig.
↔ mm	22,5 x 22,5 x 19,5
Stk./g	11,5



#	422009
↔ ↑ mm	275 x 175 x 24
Stückzahl	5 x 6
↔ mm	38 x 21 x 13
Stk./g	7



#	422169
↔ ↑ mm	275 x 175 x 24
Stückzahl	5 x 8
↔ mm	Ø 28 x 24
Stk./g	13



NEW

#	421760
↔ ↑ mm	275 x 135 x 24
Stückzahl	3 x 7
↔ mm	27 x 27 x 22
Stk./g	8,0



NEW

#	421779
↔ ↑ mm	275 x 135 x 24
Stückzahl	3 x 5
↔ mm	38,5 x 22,5 x 17,5
Stk./g	12,5



NEW

#	421781
↔ ↑ mm	275 x 135 x 24
Stückzahl	2 x 7
↔ mm	42,5 x 31 x 18,5
Stk./g	10,5

DE	FANTASIE
GB	FANTASY
IT	FANTASIA
ES	FANTASÍA



NEW

#	421784
↔ ↑ mm	275 x 135 x 24
Stückzahl	3 x 8
↔ mm	48 x 16,5 x 13,5
Stk./g	8,0



NEW

#	421794
↔ ↑ mm	275 x 135 x 24
Stückzahl	3 x 8
↔ mm	26 x 26 x 25,5
Stk./g	12,5

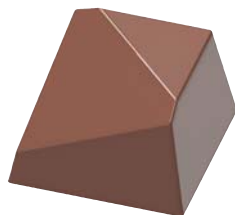

NEW

#	421799
↔ ↑ mm	275 x 135 x 24
Stückzahl	3 x 7
↔ mm	27,6 x 27,6 x 17,2
Stk./g	12,5



NEW

#	421840
↔ ↑ mm	275 x 135 x 30
Stückzahl	3 x 8
↔ mm	23 x 23 x 20
Stk./g	12



NEW

#	421842
↔ ↑ mm	275 x 135 x 30
Stückzahl	3 x 7
↔ mm	27,5 x 27,5 x 24
Stk./g	10,5



NEW

#	421848
↔ ↑ mm	275 x 135 x 24
Stückzahl	3 x 7
↔ mm	50 x 25 x 15
Stk./g	7,5



NEW

#	421859
↔ ↑ mm	275 x 135 x 26
Stückzahl	3 x 7
↔ mm	24,5 x 23,5 x 21,5
Stk./g	9,0



NEW

#	421866
↔ ↑ mm	275 x 135 x 24
Stückzahl	3 x 8
↔ mm	30,5 x 19 x 17
Stk./g	9,5



NEW

#	421858
↔ ↑ mm	275 x 135 x 24
Stückzahl	3 x 7
↔ mm	32,5 x 28,5 x 15,5
Stk./g	9,5



NEW

#	421883
↔ ↑ mm	275 x 135 x 24
Stückzahl	3 x 8
↔ mm	20 x 20 x 19
Stk./g	6,9



NEW

#	421885
↔ ↑ mm	275 x 135 x 24
Stückzahl	3 x 8
↔ mm	25,7 x 25,7 x 15,9
Stk./g	11,9

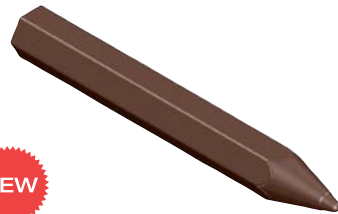

NEW

# - Doppelform	421622
↔ ↑ mm	275 x 135 x 24
Stückzahl	2 x 5
↔ mm	117 x 15 x 6,5
Stk./g	9,5

DE	FANTASIE
GB	FANTASY
IT	FANTASIA
ES	FANTASÍA



NEW

#	421903
↔ ↑ mm	275 x 135 x 24
Stückzahl	3 x 7
↔ mm	45,5 x 28,5 x 14
Stk./g	7,5



NEW

#	421904
↔ ↑ mm	275 x 135 x 24
Stückzahl	3 x 7
↔ mm	42 x 31 x 16
Stk./g	8,0



NEW

#	421028
↔ ↑ mm	275 x 135 x 24
Stückzahl	3 x 8
↔ mm	33 x 27 x 19
Stk./g	15



NEW

#	421092
↔ ↑ mm	275 x 135 x 24
Stückzahl	3 x 8
↔ mm	39 x 28 x 17
Stk./g	15



NEW

#	421156
↔ ↑ mm	275 x 135 x 24
Stückzahl	5 x 6
↔ mm	37 x 18 x 14
Stk./g	11



NEW

#	421173
↔ ↑ mm	275 x 135 x 24
Stückzahl	3 x 8
↔ mm	48 x 18 x 20
Stk./g	13



NEW

#	421330
↔ ↑ mm	275 x 135 x 24
Stückzahl	3 x 8
↔ mm	41 x 21 x 15
Stk./g	14



NEW

#	421419
↔ ↑ mm	275 x 135 x 24
Stückzahl	3 x 8
↔ mm	31 x 24 x 13
Stk./g	10



NEW

#	421479
↔ ↑ mm	275 x 135 x 24
Stückzahl	4 x 5
↔ mm	48 x 29 x 11
Stk./g	19



NEW

#	421521
↔ ↑ mm	275 x 135 x 24
Stückzahl	3 x 8
↔ mm	28,5 x 28,5 x 18
Stk./g	10



NEW

#	421544
↔ ↑ mm	275 x 135 x 24
Stückzahl	4 x 7
↔ mm	27 x 27 x 16
Stk./g	8,65



NEW

#	421545
↔ ↑ mm	275 x 135 x 24
Stückzahl	4 x 7
↔ mm	27 x 24 x 17
Stk./g	8,75

DE	FANTASIE
GB	FANTASY
IT	FANTASIA
ES	FANTASÍA



NEW

#	421555
↔↑ mm	275 x 135 x 24
Stückzahl	3 x 7
↔ mm	29,5 x 29,5 x 20,2
Stk./g	12,3



NEW

#	421559
↔↑ mm	275 x 135 x 24
Stückzahl	3 x 8
↔ mm	24,4 x 24,4 x 14,5
Stk./g	7,8



NEW

#	421564
↔↑ mm	275 x 135 x 24
Stückzahl	3 x 7
↔ mm	31 x 31 x 15,4
Stk./g	12,35



NEW

#	421575
↔↑ mm	275 x 135 x 24
Stückzahl	3 x 7
↔ mm	29 x 29 x 20
Stk./g	8,0



NEW

#	421617
↔↑ mm	275 x 135 x 24
Stückzahl	5 x 5
↔ mm	39 x 17,60 x 15,50
Stk./g	10

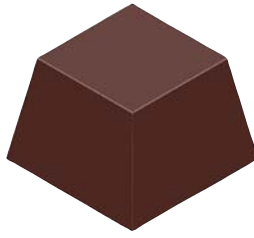

NEW

#	421630
↔↑ mm	275 x 135 x 24
Stückzahl	3 x 8
↔ mm	26 x 26 x 18,5
Stk./g	12



NEW

#	421646
↔↑ mm	275 x 135 x 24
Stückzahl	3 x 8
↔ mm	34 x 24 x 12
Stk./g	10



NEW

#	421753
↔↑ mm	275 x 135 x 24
Stückzahl	3 x 7
↔ mm	27 x 27 x 19
Stk./g	11



NEW

#	421754
↔↑ mm	275 x 135 x 28
Stückzahl	3 x 6
↔ mm	38 x 32 x 225,5
Stk./g	10



NEW

#	422392
↔↑ mm	275 x 175 x 24
Stückzahl	4 x 8
↔ mm	27,5 x 27,5 x 15
Stk./g	7



NEW

#	421764
↔↑ mm	275 x 135 x 32
Stückzahl	3 x 7
↔ mm	31 x 31 x 27
Stk./g	9,0



NEW

#	421780
↔↑ mm	275 x 135 x 24
Stückzahl	3 x 7
↔ mm	46 x 28 x 21
Stk./g	8,47

DE	FANTASIE
GB	FANTASY
IT	FANTASIA
ES	FANTASÍA

NEW



#	421782
↖↗ mm	275 x 135 x 30
Stückzahl	3 x 6
↔ mm	44,5 x 32 x 22,50
Stk./g	11

NEW



#	422371
↖↗ mm	275 x 135 x 24
Stückzahl	4 x 9 / 3 fig.
↔ mm	-
Stk./g	-

NEW



#	421905
↖↗ mm	275 x 135 x 24
Stückzahl	3 x 7
↔ mm	39,5 x 34,5 x 13,5
Stk./g	8,5

NEW



#	421906
↖↗ mm	275 x 135 x 24
Stückzahl	1 x 2
↔ mm	103,5 x 89,5 x 13,5
Stk./g	56

NEW



#	421908
↖↗ mm	275 x 135 x 24
Stückzahl	1 x 7
↔ mm	113 x 28 x 11
Stk./g	31,5

NEW



#	421911
↖↗ mm	275 x 135 x 24
Stückzahl	2 x 6
↔ mm	unterschiedlich
Stk./g	5,50

NEW



# - Doppelform	421912
↖↗ mm	275 x 135 x 24
Stückzahl	3 x 6
↔ mm	39 x 34 x 7
Stk./g	2 x 5,5

NEW

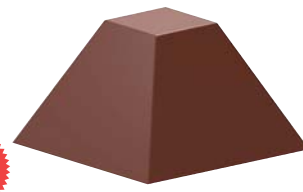

#	421915
↖↗ mm	275 x 135 x 24
Stückzahl	3 x 7
↔ mm	27,5 x 27,5 x 17
Stk./g	8

NEW



# - Doppelform	421916
↖↗ mm	275 x 135 x 24
Stückzahl	1 x 14
↔ mm	120 x 9,5 x 5
Stk./g	2 x 5

NEW



# - Doppelform	421920
↖↗ mm	275 x 135 x 24
Stückzahl	1 x 6
↔ mm	120 x 34 x 10,5
Stk./g	2 x 24

NEW



#	421921
↖↗ mm	275 x 135 x 24
Stückzahl	3 x 7
↔ mm	36,5 x 27,5 x 16,5
Stk./g	10,5

NEW



#	421922
↖↗ mm	275 x 135 x 24
Stückzahl	3 x 7
↔ mm	35,5 x 35,5 x 17
Stk./g	12

DE	FANTASIE
GB	FANTASY
IT	FANTASIA
ES	FANTASÍA



NEW

#	421923
↙↑ mm	275 x 135 x 30
Stückzahl	3 x 8
↔ mm	26,5 x 26,5 x 22
Stk./g	9,5



NEW

#	421924
↙↑ mm	275 x 135 x 24
Stückzahl	3 x 7
↔ mm	31 x 31 x 26,5
Stk./g	9,5



NEW

#	421929
↙↑ mm	275 x 135 x 24
Stückzahl	1 x 10
↔ mm	99,5 x 19,5 x 11,5
Stk./g	17,5



NEW

#	421930
↙↑ mm	275 x 135 x 24
Stückzahl	3 x 8
↔ mm	26 x 20 x 15
Stk./g	9,5



NEW

#	421932
↙↑ mm	275 x 135 x 30
Stückzahl	3 x 7
↔ mm	28 x 28 x 24
Stk./g	12,85



NEW

#	421935
↙↑ mm	275 x 135 x 24
Stückzahl	3 x 7
↔ mm	35 x 31 x 16,5
Stk./g	11



NEW

#	421936
↙↑ mm	275 x 135 x 24
Stückzahl	1 x 4
↔ mm	117,5 x 49,5 x 9
Stk./g	57



NEW

# – Doppelform	421939
↙↑ mm	275 x 135 x 24
Stückzahl	3 x 7
↔ mm	35 x 35 x 8,5
Stk./g	2 x 7



NEW

#	422391
↙↑ mm	275 x 175 x 24
Stückzahl	3 x 8
↔ mm	47 x 19 x 17
Stk./g	13

DE	TASSEN
GB	CUPS
IT	TAZZE
ES	TAZAS



#	421002
↙↑ mm	275 x 135 x 24
Stückzahl	3 x 7
↔ mm	Ø 30 x 19
Stk./g	14



#	421003
↙↑ mm	275 x 135 x 24
Stückzahl	3 x 8
↔ mm	35 x 26 x 19
Stk./g	14



#	421342
↙↑ mm	275 x 135 x 24
Stückzahl	4 x 8
↔ mm	Ø 28 x 27
Stk./g	17



#	421387
↙↑ mm	275 x 135 x 24
Stückzahl	3 x 8
↔ mm	Ø 30 x 20
Stk./g	11



#	421585
↙↑ mm	275 x 135 x 24
Stückzahl	3 x 8
↔ mm	26 x 32 / 86 x 14,5
Stk./g	7

DE	KUGELN
GB	SPHERES
IT	SFERE
ES	ESFERAS



# - Doppelform	421158
↙↑ mm	275 x 135 x 24
Stückzahl	4 x 9
↔ mm	Ø 25
Stk./g	2 x 4



# - Doppelform	421217
↙↑ mm	275 x 135 x 24
Stückzahl	3 x 8
↔ mm	Ø 30
Stk./g	2 x 9



# - Doppelform	421258
↙↑ mm	275 x 135 x 24
Stückzahl	4 x 8
↔ mm	Ø 27
Stk./g	2 x 6

DE	KUGELN
GB	SPHERES
IT	SFERE
ES	ESFERAS



# - Doppelform	421495
↔ ↑ mm	275 x 135 x 24
Stückzahl	43 x 10
↔ mm	Ø 20
Stk./g	2 x 2,5



# - Doppelform	421648
↔ ↑ mm	275 x 135 x 32
Stückzahl	2 x 4
↔ mm	Ø 50
Stk./g	38



# - Doppelform	422361
↔ ↑ mm	275 x 175 x 24
Stückzahl	5 x 8
↔ mm	27 x 27 x 13
Stk./g	2 x 6



NEW

#	421797
↔ ↑ mm	275 x 135 x 24
Stückzahl	6 x 13
↔ mm	14 x 7
Stk./g	1,0



NEW

#	421157
↔ ↑ mm	275 x 135 x 30
Stückzahl	3 x 7
↔ mm	29,7 x 25
Stk./g	16,8



NEW

# - Doppelform	422252
↔ ↑ mm	275 x 175 x 35
Stückzahl	8
↔ mm	59 x 29
Stk./g	71



NEW

#	421291
↔ ↑ mm	275 x 135 x 40
Stückzahl	1 x 14
↔ mm	45 x 38
Stk./g	44



NEW

#	421292
↔ ↑ mm	275 x 135 x 35
Stückzahl	4 x 7
↔ mm	35 x 30
Stk./g	25



NEW

# - Doppelform	422022
↔ ↑ mm	275 x 175 x 24
Stückzahl	5 x 8
↔ mm	30 x 15
Stk./g	9,0



NEW

#	422116
↔ ↑ mm	275 x 175 x 28
Stückzahl	4 x 8
↔ mm	29 x 23
Stk./g	14



NEW

# - Doppelform	422251
↔ ↑ mm	275 x 175 x 30
Stückzahl	12
↔ mm	50 x 25
Stk./g	40

DE	KUGELN
GB	SPHERES
IT	SFERE
ES	ESFERAS



NEW

# - Doppelform	422253
↔ ↑ mm	275 x 175 x 40
Stückzahl	2 x 3
↔ mm	70 x 35
Stk./g	113



NEW

# - Doppelform	422254
↔ ↑ mm	275 x 175 x 40
Stückzahl	2 x 3
↔ mm	80 x 40
Stk./g	162



NEW

#	422295
↔ ↑ mm	275 x 175 x 24
Stückzahl	4 x 8
↔ mm	29 x 21
Stk./g	13



NEW

# - Doppelform	421909
↔ ↑ mm	275 x 135 x 24
Stückzahl	3 x 8
↔ mm	25 x 25 x 12,5
Stk./g	2 x 5



NEW

#	421867
↔ ↑ mm	275 x 135 x 30
Stückzahl	3 x 8
↔ mm	25,5 x 22,5
Stk./g	9,5

DE	BOUCHÉS & BLÖCKE
GB	BOUCHÉS & BLOCS
IT	CIOCCOLATINI RIPIENI, BLOCCHI E TAVOLETTE
ES	BOMBÓNES RELLENOS Y BLOQUES



#	421367
↔ ↑ mm	275 x 135 x 24
Stückzahl	1 x 5
↔ mm	117 x 50 x 11
Stk./g	84



#	421421
↔ ↑ mm	275 x 135 x 24
Stückzahl	1 x 3
↔ mm	130 x 79 x 9
Stk./g	105



#	421431
↔ ↑ mm	275 x 135 x 24
Stückzahl	1 x 3
↔ mm	124 x 77 x 11
Stk./g	102

DE	BOUCHÉS & BLÖCKE
GB	BOUCHÉS & BLOCS
IT	CIOCCOLATINI RIPIENI, BLOCCHI E TAVOLETTE
ES	BOMBONES RELLENOS Y BLOQUES



#	421588
↔ ↑ mm	275 x 135 x 24
Stückzahl	3 x 3
↔ → mm	67 x 33 x 5
Stk./g	12

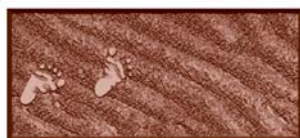

#	421665
↔ ↑ mm	275 x 135 x 24
Stückzahl	1 x 4
↔ → mm	118 x 53 x 9,5
Stk./g	61



NEW

#	421132
↔ ↑ mm	275 x 135 x 24
Stückzahl	1 x 7
↔ → mm	125 x 30 x 13
Stk./g	50



NEW

#	421256
↔ ↑ mm	275 x 135 x 24
Stückzahl	1 x 7
↔ → mm	128 x 29 x 14
Stk./g	47



NEW

#	421611
↔ ↑ mm	275 x 135 x 24
Stückzahl	4 x 2
↔ → mm	123 x 22 x 6
Stk./g	16,5



NEW

#	421745
↔ ↑ mm	275 x 135 x 24
Stückzahl	2 x 5
↔ → mm	63 x 18 x 18
Stk./g	10



NEW

#	421667
↔ ↑ mm	275 x 135 x 24
Stückzahl	2 x 2
↔ → mm	125 x 55 x 7
Stk./g	47



NEW

#	421796
↔ ↑ mm	275 x 135 x 24
Stückzahl	1 x 5
↔ → mm	105 x 45 x 7,5
Stk./g	26



NEW

#	421854
↔ ↑ mm	275 x 135 x 24
Stückzahl	1 x 8
↔ → mm	117,5 x 25 x 14,5
Stk./g	32



NEW

#	421872
↔ ↑ mm	275 x 135 x 24
Stückzahl	1 x 8
↔ → mm	116,5 x 22,5 x 15
Stk./g	37,7



NEW

#	421898
↔ ↑ mm	275 x 135 x 24
Stückzahl	1 x 3
↔ → mm	79,5 x 79,5 x 13,5
Stk./g	77,5



NEW

#	421899
↔ ↑ mm	275 x 135 x 24
Stückzahl	1 x 8
↔ → mm	117,5 x 23,5 x 14
Stk./g	36,5

DE	BOUCHÉS & BLÖCKE
GB	BOUCHÉS & BLOCS
IT	CIOCCOLATINI RIPIENI, BLOCCHI E TAVOLETTE
ES	BOMBÓNES RELLENOS Y BLOQUES



NEW

#	421612
↔ ↑ mm	275 x 135 x 24
Stückzahl	2 x 2
↔ mm	114 x 50 x 8
Stk./g	55



NEW

#	421642
↔ ↑ mm	275 x 135 x 24
Stückzahl	1 x 2
↔ mm	100 x 100 x 15
Stk./g	92

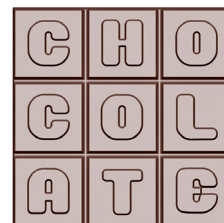

NEW

#	421685
↔ ↑ mm	275 x 135 x 24
Stückzahl	1 x 2 fig.
↔ mm	100 x 100 x 8
Stk./g	75



NEW

#	421769
↔ ↑ mm	275 x 135 x 24
Stückzahl	2 x 2
↔ mm	124,5 x 55,5 x 6,5
Stk./g	45



NEW

#	422110
↔ ↑ mm	275 x 175 x 24
Stückzahl	1 x 3
↔ mm	156 x 77 x 8
Stk./g	80



NEW

#	422162
↔ ↑ mm	275 x 175 x 24
Stückzahl	1 x 3
↔ mm	155 x 77 x 9
Stk./g	108



NEW

#	422276
↔ ↑ mm	275 x 175 x 30
Stückzahl	1 x 1
↔ mm	250 x 160 x 25
Stk./g	1000



NEW

#	422436
↔ ↑ mm	275 x 175 x 24
Stückzahl	1 x 3
↔ mm	156 x 77 x 4
Stk./g	51,80



NEW

#	422437
↔ ↑ mm	275 x 175 x 24
Stückzahl	1 x 3
↔ mm	156 x 77 x 5
Stk./g	60



NEW

#	422438
↔ ↑ mm	275 x 175 x 24
Stückzahl	1 x 3
↔ mm	156 x 77 x 6
Stk./g	70,70

DE	MEERESFRÜCHTE
GB	SEAFRUIT
IT	FRUTTI DI MARE
ES	MARISCOS



#	421084
↙↑ mm	275 x 135 x 24
Stückzahl	3 x 8
↔ mm	35 x 29 x 21
Stk./g	15



#	421170
↙↑ mm	275 x 135 x 24
Stückzahl	4 x 7 / 5 Fig.
↔ mm	38 x 20 x 7
Stk./g	4,5



# – Doppelform	421586
↙↑ mm	275 x 135 x 24
Stückzahl	22 / 9 Fig.
↔ mm	unterschiedlich
Stk./g	2 x 6

DE	LOLLIES
GB	LOLLIES
IT	LECCA LECCA
ES	PIRULETAS



#	421294
↙↑ mm	275 x 135 x 24
Stückzahl	1 x 10
↔ mm	66 x 35 x 10
Stk./g	16



#	421354
↙↑ mm	275 x 135 x 24
Stückzahl	1 x 6
↔ mm	48 x 37 x 15
Stk./g	11



#	421480
↙↑ mm	275 x 135 x 24
Stückzahl	1 x 4
↔ mm	54 x 63 x 12
Stk./g	29



#	421623
↙↑ mm	275 x 135 x 24
Stückzahl	1 x 4
↔ mm	49,5 x 49,5 x 11
Stk./g	16,5



#		
450900	500 Stk.	



www.schneider-gmbh.com

<http://www.schneider-gmbh.com/de/videos.html>

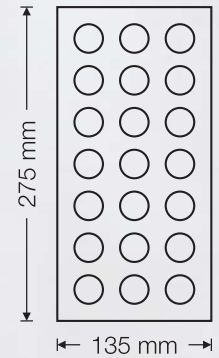

DE	MAGNETFORMEN
GB	MAGNET MOULDS
IT	STAMPI MAGNETICI
ES	MOLDES DE IMÁN

Das Gewicht wurde auf der Grundlage von Vollmilch-Schokolade bestimmt und kann je nach Schokoladensorte, der Füllung sowie der Gießtechnik, Abweichungen verzeichnen.

Il peso viene determinato in base a cioccolato al latte e può subire variazioni secondo il tipo di cioccolato impiegato, il ripieno e la tecnica di fusione.

The weight is based on a moulding with solid milk chocolate and may depend on your chocolate, filling and way of moulding.

El peso queda determinado a base de chocolate con leche entera y puede ser distinto según el tipo de chocolate, relleno y técnica de moldeo.

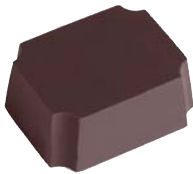

#	430000
↖↗ mm	275 x 135 x 24
Stückzahl	3 x 5
↔ mm	35 x 28 x 14
Stk./g	13,5



#	430001
↖↗ mm	275 x 135 x 24
Stückzahl	4 x 6
↔ mm	24 x 24 x 14
Stk./g	9,5



#	430007
↖↗ mm	275 x 135 x 24
Stückzahl	3 x 6
↔ mm	32 x 24 x 11
Stk./g	10

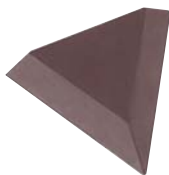

#	430008
↖↗ mm	275 x 135 x 24
Stückzahl	3 x 4
↔ mm	46 x 40 x 15
Stk./g	13,25

DE	NEUTRALE TRANSFERFOLIE
GB	NEUTRAL TRANSFER SHEETS
IT	TRASFERELLI NEUTRI
ES	HOJAS NEUTRALES PARA TRANSFERENCIA



#	↔ mm		
451000	273 x 132	1 Pack = 100 Stk./pcs.	

Eis
Ice cream
Gelato
Helado



DE	EISSPACHTELN
GB	ICE CREAM SPATULAS
IT	SPATOLE PER GELATO
ES	PALA CUCHARA HELADO

Material: Edelstahl, Griff aus Kunststoff made of stainless steel, with plastic handle

#	↗ mm		🛒
195210	260	rot transparent / red transparent	1
195220	260	blau transparent / blue transparent	1
195230	260	gelb transparent / yellow transparent	1
195250	260	schwarz transparent / black transparent	1
195260	260	transparent / transparent	1
195290	260	100% Kunststoff / 100% plastic	1
195100	260	● blau/blue	1
195110	300	● blau/blue	1
195120	260	● rot/red	1
195130	300	● rot/red	1
195140	260	● gelb/yellow	1
195150	300	● gelb/yellow	1
195180	260	● rosa/pink	1
195190	300	● rosa/pink	1



DE	EISDIPPER
GB	ICE CREAM DIPPERS
IT	SPATOLE PER GELATO
ES	RACIONADORES HELADO COMPACTOS

Material: lebensmittelechtes Aluminium, wärmeleitende Flüssigkeit im Griff (125 mm) made of aluminum (food safe), with heat conductive fluid inside handle (125 mm)

#	🔗 l	Ø mm	🛒
190200	1/12	67	1
190210	1/16	59	1
190220	1/20	56	1
190230	1/24	51	1
190240	1/30	49	1
190250	1/40	45	1

DE	EISPORTIONIERER
GB	ICE CREAM SCOOPS
IT	PORZIONATORI
ES	RACIONADORES HELADO

Material: Edelstahl, ergonomischer Griff aus Kunststoff.

Anwendung: für Eis, Früchte, Reis, Mousse und andere Speisen.

Made of stainless steel, with ergonomic plastic handle.

Usable for ice cream, fruits, rice, mousse and other food.



	#	l	Ø mm	
<input checked="" type="checkbox"/>	195010	1/8	80	1
<input checked="" type="checkbox"/>	195015	1/12	65	1
<input checked="" type="checkbox"/>	195020	1/16	61	1
<input checked="" type="checkbox"/>	195025	1/20	56	1
<input checked="" type="checkbox"/>	195030	1/24	51	1
<input checked="" type="checkbox"/>	195035	1/30	49	1
<input checked="" type="checkbox"/>	195040	1/36	46	1
<input checked="" type="checkbox"/>	195045	1/40	44	1
<input checked="" type="checkbox"/>	195050	1/50	42	1
<input checked="" type="checkbox"/>	195055	1/60	39	1
<input checked="" type="checkbox"/>	195060	1/100	30	1

Material: Edelstahl, schwere Profi-Qualität

made of stainless steel, heavy quality for professionals



	#	l	Ø mm	
	195400	1/8	80	1
	195405	1/12	67	1
	195410	1/16	59	1
	195415	1/20	56	1
	195420	1/24	53	1
	195425	1/30	50	1
	195430	1/36	48	1
	195435	1/40	44	1
	195440	1/50	40	1

Material: Edelstahl, schwere Profi-Qualität. „OVAL“

made of stainless steel, heavy quality for professionals. „OVAL“



	#	l	↔ mm	
	195450	1/30	58 x 46	1





i auch für Linkshänder
lieferbar / available also for lefthander



DE	EISPORTIONIERER
GB	ICE CREAM SCOOPS
IT	PORZIONATORI
ES	RACIONADORES HELADO

Material: Edelstahl, Griff aus blauem Kunststoff

made of stainless steel, with blue plastic handle

#	l	Ø mm	
190133	1/8	80	1
190135	1/10	70	1
190137	1/12	67	1
190139	1/16	59	1
190140	1/20	56	1
190142	1/22	53	1
190144	1/24	51	1
190146	1/30	49	1
190148	1/36	47	1
190150	1/40	45	1
190151	1/45	44	1
190152	1/50	43	1
190153	1/55	41	1
190154	1/60	40	1
190155	1/65	38	1
190156	1/70	35	1
190159	1/100	30	1

“HERZ”

“HEART”

#	l		
190132	1/25		1

“QUADRAT”

“SQUARE”

#	l	↔ mm	
190120	1/20	37 x 37 x 37	1
190130	1/30	32 x 32 x 32	1

DE	EISPORTIONIERER “STANDARD”
GB	ICE CREAM SCOOPS “STANDARD”
IT	PORZIONATORI “STANDARD”
ES	RACIONADORES HELADO “STANDARD”

Material: Edelstahl, Griff massiv Messing, verchromt

bowls made of stainless steel, handle brass, chrome-plated



#	l	Ø mm	
190000	1/4	100	1
190002	1/8	80	1
190004	1/10	70	1
190006	1/12	67	1
190008	1/16	59	1
190010	1/20	56	1
190011	1/22	53	1
190012	1/24	51	1
190014	1/30	49	1
190015	1/36	47	1
190016	1/40	45	1
190017	1/50	43	1
190018	1/60	40	1
190019	1/65	38	1
190020	1/70	35	1
190022	1/100	30	1

DE	EISTÜTENHALTER
GB	ICE CREAM CONE HOLDERS
IT	PORTA CONI
ES	PORTA CONOS DE HELADO

Material: Edelstahl, mit Antirutsch-Füßchen made of stainless steel, with non-slip feet

für 3 Eistüten

for 3 cones

#	Ø mm	→ mm	↓ mm	↑ mm	
190300	26	200	95	85	1



für 4 Eistüten

for 4 cones

#	Ø mm	→ mm	↓ mm	↑ mm	
190305	26	270	95	85	1



für 4 Eistüten, "MAXI"

for 4 cones, "MAXI"

#	Ø mm	→ mm	↓ mm	↑ mm	
190308	2 x 26/2 x 31	270	95	85	1



aus Acryl

made of acrylic

für 3 Eistüten

for 3 cones

#	Ø mm	→ mm	↓ mm	↑ mm	
172100	34	185	90	95	1



für 4 Eistüten

for 4 cones

#	Ø mm	→ mm	↓ mm	↑ mm	
172101	34	250	90	95	1



Material: Edelstahl, für 4 Eistüten

made of stainless steel, for 4 cones

#	Ø mm	↑ mm	
190310	165	140	1



DE	EISTÜTENHALTER "SILO"
GB	ICE CREAM CONE HOLDER "SILO"
IT	PORTA CONI "SILO"
ES	PORTA CONOS DE HELADO "SILO"

aus Acryl

made of acrylic

#	Ø mm	→ mm	↓ mm	↑ mm	
172200	45	120	105	500	1
172201	4 x 24 / 1 x 30	140	140	500	1
172202	9 x 24 / 4 x 30	205	205	500	1
172203	12 x 24 / 6 x 30	245	185	590	1
172204	12 x 24 / 6 x 30	245	185	550	1

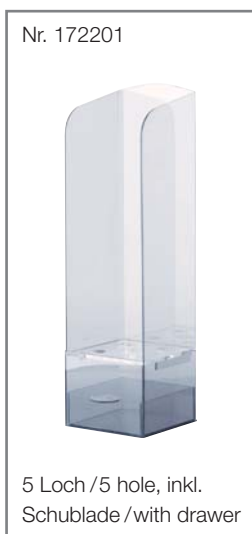

DE	LÖFFELFLÖTEN
GB	SPOON HOLDERS
IT	PORTA CUCIAINI
ES	PORTA CUCHARITAS

mit 3 quadratischen Löffelboxen aus Acryl, inklusive Distanzeinlage

with 3 square boxes made of acrylic, including distance spacer

#	→ mm	↓ mm	↑ mm	
172300	225	150	150	1



DE	SERVIETTENSPENDER / SERVIETTENHALTER
GB	NAPKIN HOLDERS
IT	PORTATOVAGLIOLI
ES	SERVILLETERO

für 100 Servietten 170 x 170 mm, Material: Edelstahl

for 100 napkins size 170 x 170 mm, made of stainless steel

#	→ mm	↓ mm	↑ mm	
195700	95	100	130	1

DE	EISBEHÄLTER
GB	ICE CREAM CONTAINERS
IT	BACINELLE PER GELATO
ES	CUBETAS HELADO

für Eisvitrienen,
Material: Edelstahl

for ice cream cabinets,
made of stainless steel

#	↗ mm	→ mm	↑ mm	📦 l	🛒
199616	360	165	80	3,8	1
199610	360	165	120	5,4	1
199611	360	165	150	7,1	1
199612	360	165	180	8,8	1
199615	360	250	80	5,0	1
199614	360	250	120	8,0	1
199617	360	250	150	10,8	1
199618	360	250	180	12,6	1
199619	330	165	80	3,5	1
199622	330	165	120	5,0	1
199623	330	165	150	6,5	1
199624	330	165	180	8,0	1
199613	265	165	170	4,8	1



Material: Polycarbonat, unzerbrechlich

made of polycarbonate, unbreakable

#	↗ mm	→ mm	↑ mm	📦 l	🛒
199620	360	165	120	5,0	1
199621	360	250	80	6,5	1



DE	DECKEL FÜR EISBEHÄLTER
GB	LID FOR ICE CREAM CONTAINERS
IT	COPERCHI PER BACINELLE PER GELATO
ES	TAPA PARA CUBETAS HELADO

Material: Plexiglas

made of plexiglass

#	für / for	→ mm	↗ mm	🛒
199630	199610, 199611, 199612, 199620	165	360	1
199629	199613	165	265	1



Kellner- / Notablocks Waiter and note pads



DE	NOTIZBLOCK
GB	NOTEPAD
IT	BLOCHHETTI DA NOTA
ES	BLOC DE NOTAS

Druck: 1/0-farbig in rot; 50 Blatt pro Block;
Papier: holzfrei weiß 60 g / m²
Verpackung: 25 Blocks = 1 VE

Print: 1/0- color in red; 50 sheets per block
Paper: woodfree 60 g / m²
1 x 25 notepads packed

#	↔ mm	
711111	DIN A5 – 148 x 210	25



DE	KELLNER-/NOTABLOCKS
GB	WAITER PADS
IT	BLOCCHETTI PER CAMERIERI
ES	BLOC DE NOTAS

Neutrale Blocks, 40 Blatt pro Block,
farblose Kopfverleimung,
Verpackung: 2 x 25 Blocks in Folie

Unprinted, 40 sheets, colorless glue,
2 x 25 notepads packed

#	↔ mm		
711000	70 x 150	holzfrei, weiss / woodfree 60 g / m ²	50
710000	70 x 150	Zeitungsdruckpapier / newsprint / 49 g / m ²	50



DE	THERMO-GUEST-CHEQUES
GB	THERMO-GUEST-CHEQUES

Sondergrößen auf Anfrage.

special sizes upon request.

#	↔ mm		
820601	120 x 210 0/1-farbig bedruckt "gesetzl. Bewirgungsnachweis"	○ weiß / white	3500



- Diverse Ausführungen in Format, Blattzahl und Grammatur
- Offsetdruck, 1–4 farbig
- Zeitungsdruckpapier oder holzfrei weiß Offset
- Individuelle Verpackungen
- Different designs, sizes, quantities of sheets and grammages
- Offset print, 1–4 colours possible
- Made of raised newsprint paper or wood free white offset print
- Individual packaging

Individuell bedruckte Notablocks und Kellnerblocks dienen als Werbeträger für Brauereien, Kaffeerösterereien, Mineralbrunnen, Spirituosen- und Spielehersteller.

Wir produzieren Kellnerblocks in den Qualitäten „Zeitungsdruckpapier“ und „Holzfrei weiß Offset“ in unterschiedlichen Grammaturen.

Alle gängigen Formate sowie Sonderabmessungen bis DIN A4 werden von uns mit der von Ihnen gewünschten Blattzahl hergestellt.

Verschiedene Offset-Druckmaschinen ermöglichen einen hochwertigen 1–4 farbigen Druck auf Vorder- und Rückseite.

Wir bieten Ihnen eine einwandfreie Druckqualität mit bestmöglichem Lieferservice an. Eine Vielzahl deutscher und internationaler Unternehmen vertrauen uns seit Jahren.

Individually printed waiter and note pads are used as a perfect advertising media for breweries, producers of coffee, mineral water and spirits, as well as game manufacturers.

We produce notepads and waiter pads in the qualities „improved newsprint paper“ and „woodfree white offset“ with different grammages.

All common formats and also special dimensions up to DIN A4 are manufactured with the required number of sheets.

A variety of offset machines allow for top quality front and back printing in 1–4 colors.

We offer you a perfect print quality with a best possible delivery service. For many years a large number of German and international companies trust us.



Technische
Papiere

Technical
papers

DE	THERMO-ROLLEN FÜR WAAGEN – 55 g/m ²
GB	THERMAL ROLLS FOR SCALES – 55 g/m ²

#		für / for		
820419	62 mm x 50 m x 12 mm	Mettler	○ weiß / white	50
820421	62 mm x 50 m x 12 mm	Mettler	● gelb / yellow	50
820420	62 mm x 50 m x 12 mm	Mettler	● rot / red	50
820422	62 mm x 50 m x 12 mm	Mettler	● grün / green	50
820423	62 mm x 50 m x 12 mm	Mettler	● blau / blue	50
820138	62 mm x 100 m x 12 mm	Mettler	○ weiß / white	27
820134	57 mm x 40 m x 12 mm (IW)	Mettler	○ weiß / white	50
820060	58 mm x 50 m x 12 mm	Bizerba	○ weiß / white	48
820407	58 mm x 50 m x 12 mm	Bizerba	○ weiß / white	50
820413	58 mm x 50 m x 12 mm	Bizerba	● gelb / yellow	50
820410	58 mm x 50 m x 12 mm	Bizerba	● rot / red	50
820414	58 mm x 50 m x 12 mm	Bizerba	● grün / green	50
820411	58 mm x 50 m x 12 mm	Bizerba	● blau / blue	50
820020	72 mm x 50 m x 12 mm	Bizerba	○ weiß / white	50
820268	57 mm x 50 m x 12 mm	Berkel	○ weiß / white	50
820041	60 mm x 50 m x 12 mm	Berkel	○ weiß / white	50
820241	60 mm x 100 m x 12 mm	Berkel	○ weiß / white	24
820086	51,5 mm x 100 m x 38,5 mm	Berkel	○ weiß / white	24
820001	51,5 mm x 60 m x 40 mm	TEC	○ weiß / white	45
820032	62 mm x Ø 58 mm x 12 mm	Testut	○ weiß / white	50
820404	57 mm x 25 m x 12 mm (IW)	Testut	○ weiß / white	50
820031	57 mm x 25 m x 12 mm (IW)	Testut	○ weiß / white	100
820286	58 mm x 50 m x 12 mm	DIGI	○ weiß / white	48
820121	50 mm x 200 m x 12 mm (IW)	DIGI	○ weiß / white	20
820132	60 mm x 105 m x 38,5 mm	DIGI	○ weiß / white	15
820125	42 mm x 50 m x 12 mm	YAMATO	○ weiß / white	50
820122	42 mm x 100 m x 12 mm	YAMATO	○ weiß / white	36
820191	62 mm x Ø 58 mm x 12 mm	HELMAC	○ weiß / white	50
820181	62 mm x 50 m x 12 mm	HELMAC	○ weiß / white	50
820432	62 mm x Ø 80 mm x 17,5 mm	HELMAC	○ weiß / white	60
820033	60 mm x 25 m x 12 mm	METO	○ weiß / white	100
820037	62 mm x 25 m x 12 mm	OMEGA	○ weiß / white	100
820111	60 mm x Ø 55 mm x 12 mm	EPELSA	○ weiß / white	50
820116	58 mm x 40 m x 12 mm	GRAEF/ DATA LINE	○ weiß / white	50
820298	58 mm x 45 m x 12 mm	TALIANA- MACCHI	○ weiß / white	50
820035	58 mm x 35 m x 12 mm	DIBAL	○ weiß / white	50
820141	60 mm x Ø 60 mm x 12 mm (IW)	DIBAL	○ weiß / white	50

- Andere Abmessungen, Sondergrößen oder Verpackungseinheiten auf Anfrage.
- Weitere Gramaturen (48, 70, 80 g/m²), sowie BPA- und / oder Phenolfrei sind ebenfalls lieferbar. Bitte fragen Sie gerne bei uns an!

- All current dimensions available – special sizes upon request.
- Further paper qualities (48, 70, 80 g/m²) as well as BPA free and / or phenol-free paper are also available.

DE	THERMO-ROLLEN FÜR KASSEN – 55 g/m ²
GB	THERMAL ROLLS FOR CASH REGISTERS – 55 g/m ²

#		für / for		
820119	57 mm x 10 m x 12 mm, blanko	EC-Cash	○ weiß / white	50
821154	57 mm x 10 m x 12 mm, 0/1-farbig "Lastschrift" (SEPA)	EC-Cash	○ weiß / white	50
821165	57 mm x 12 m x 12 mm	EC-Cash	○ weiß / white	50
820187	57 mm x 12 m x 12 mm 0/1-farbig "Lastschrift" (SEPA)	EC-Cash	○ weiß / white	50
821083	57 mm x 15 m x 12 mm	EC-Cash	○ weiß / white	50
820943	57 mm x 15 m x 12 mm 0/1-farbig "Lastschrift" (SEPA)	EC-Cash	○ weiß / white	50
820335	57 mm x 18 m x 12 mm	EC-Cash	○ weiß / white	50
821459	57 mm x 18 m x 12 mm 0/1-farbig "Lastschrift" (SEPA)	EC-Cash	○ weiß / white	50
820306	57 mm x 25 m x 12 mm, blanko	EC-Cash	○ weiß / white	50
820248	57 mm x 25 m x 12 mm, 0/1-farbig "Lastschrift" (SEPA)	EC-Cash	○ weiß / white	10
820008	57 mm x 25 m x 12 mm, 0/1-farbig "Lastschrift" (SEPA)	EC-Cash	○ weiß / white	50
820408	57 mm x 50 m x 12 mm, blanko	EC-Cash	○ weiß / white	50
820009	57 mm x 50 m x 12 mm, 0/1-farbig "Lastschrift" (SEPA)	EC-Cash	○ weiß / white	50
820154	80 mm x 80 m x 12 mm, 0/1-farbig "Lastschrift" (SEPA)	EPSON	○ weiß / white	50
820991	80 mm x 80 m x 12 mm, 0/1-farbig "Bewirgungsnachweis"	EPSON	○ weiß / white	30
820092	80 mm x 50 m x 12 mm	EPSON	○ weiß / white	50
820239	80 mm x 50 m x 12 mm (wärmebeständig)	EPSON	○ weiß / white	50
820227	80 mm x 50 m x 12 mm	EPSON	● rot / red	50
820215	80 mm x 70 m x 12 mm	EPSON	○ weiß / white	50
820416	80 mm x 80 m x 12 mm	EPSON	○ weiß / white	30
820415	80 mm x 80 m x 12 mm	EPSON	○ weiß / white	40
820097	80 mm x 80 m x 12 mm	EPSON	○ weiß / white	50
820409	57 mm x 50 m x 12 mm	SHARP	○ weiß / white	50
820153	57,5 mm x 50 m x 17,5 mm (70 gr.)	SHARP	○ weiß / white	50
820135	57 mm x Ø 80 mm x 17,5 mm	SHARP	○ weiß / white	50
820136	57 mm x 80 m x 12 mm	SHARP	○ weiß / white	50
820242	80 mm x 40 m x 12 mm	SHARP	○ weiß / white	50
820250	57,5 mm x 50 m x 17,5 mm (70 gr.)	CASIO	○ weiß / white	50
820145	60 mm x 70 m x 12 mm	CASIO	○ weiß / white	60
820049	60 mm x Ø 80 mm x 18,4 mm	CASIO	○ weiß / white	50
820120	58 mm x 35 m x 12 mm	NORIS-XT	○ weiß / white	50
820127	112 mm x Ø 50 mm x 12 mm	PANASONIC	○ weiß / white	50
820606	57 mm x 200 m x 25 mm	TOMRA	○ weiß / white	12



DE	THERMO-ROLLEN FÜR KASSEN – 55 g/m ²
GB	THERMAL ROLLS FOR CASH REGISTERS – 55 g/m ²

bedruckt 0/1farbig – “Tankstellentext, neutral”

#			
820321	58 mm x 50 m x 12 mm	○ weiß / white	50
820320	60 mm x 50 m x 12 mm	○ weiß / white	50
820319	80 mm x 50 m x 12 mm	○ weiß / white	50
820931	80 mm x 80 m x 12 mm	○ weiß / white	50

bedruckt 0/1farbig – “e-loading-Text”

820302	57,5 mm x 26 m x 12 mm	○ weiß / white	50
--------	------------------------	----------------	----

DE	KASSENROLLEN HOLZFREI – 60 g/m ²
GB	CASH REGISTERS ROLLS WOODFREE – 60 g/m ²

#			
830039	27 mm x Ø 70 mm x 12 mm	○ weiß / white	100
830006	44 mm x Ø 70 mm x 12 mm	○ weiß / white	100
830007	44 mm x Ø 70 mm x 17,5 mm	○ weiß / white	100
830008	44 mm x Ø 80 mm x 12 mm	○ weiß / white	100
830001	44 mm x Ø 80 mm x 17,5 mm	○ weiß / white	100
830040	57 mm x Ø 50 mm x 12 mm	○ weiß / white	100
830003	57 mm x 40 m x 12 mm	○ weiß / white	100
830024	57 mm x Ø 70 mm x 12 mm	○ weiß / white	100
830025	58 mm x Ø 70 mm x 17,5 mm	○ weiß / white	100
830017	70 mm x 40 m x 12 mm	○ weiß / white	100
830020	70 mm x Ø 70 mm x 12 mm	○ weiß / white	100
830018	70 mm x 50 m x 12 mm	○ weiß / white	50
830047	70 mm x Ø 80 mm x 12 mm	○ weiß / white	50
830063	76 mm x Ø 60 mm x 12 mm	○ weiß / white	100
830021	76 mm x 40 m x 12 mm	○ weiß / white	50
830012	76 mm x 40 m x 12 mm	○ weiß / white	100
830019	76 mm x Ø 70 mm x 12 mm	○ weiß / white	100
830050	76 mm x Ø 70 mm x 17,5 mm	○ weiß / white	100
830048	76 mm x Ø 80 mm x 12 mm	○ weiß / white	50
830027	114 mm x Ø 60 mm x 12 mm	○ weiß / white	50
830033	114 mm x Ø 80 mm x 12 mm	○ weiß / white	30

Journalrolle für Tankstellen, blanko

830119	70 mm x 50 m x 12 mm	○ weiß / white	50
--------	----------------------	----------------	----

bedruckt 0/1farbig – “Tankstellentext, neutral”

830120	70 mm x 50 m x 12 mm	○ weiß / white	50
--------	----------------------	----------------	----

DE	TELEFAX-ROLLEN – 55 g/m ²
GB	FAX ROLLS – 55 g/m ²

#			
810173	210 mm x 15 m x 12 mm		6
810021	210 mm x 30 m x 12 mm		6
810174	216 mm x 15 m x 12 mm		6
810070	216 mm x 30 m x 12 mm		6



DE SD-PAPIER ROLLEN (2-FACH)
GB CARBONLESS ROLLS (DOUBLE)

#	Qual./qual.			
830090	CB/CF	44 mm x 25 m x 12 mm	○ ○ w/w / w/w	50
830092	CB/CF	57 mm x 20 m x 12 mm	○ ● w/g / w/y	100
830011	CB/CF	57 mm x 25 m x 12 mm	○ ○ w/w / w/y	50
830091	CB/CF	57 mm x 25 m x 12 mm	○ ● w/g / w/y	50
830057	CB/CF	70 mm x 25 m x 12 mm	○ ○ w/w / w/w	50
830056	CB/CF	76 mm x 25 m x 12 mm	○ ○ w/w / w/w	50



DE LINERLESS-ENDLOSETIKETTEN
GB LINERLESS LABELS

aus Thermo-TOP-Printerpapier,
 mit hochwertigem Hotmelt-Kleber,
 beidseitiger leimfreier Grifftrand

made of Thermo-Top printer paper,
 with high-quality hotmelt glue, both sides
 glue-free area

#			
880115	58 mm x 65 m x 40 mm	○ weiß / white	30
880258	58 mm x 100 m x 40 mm	○ weiß / white	18

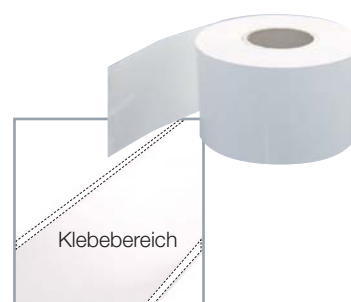

DE THERMO-ECO-HAFTETIKETTEN
GB THERMAL LABELS

#		für / for	Stk./Rolle/ labels/roll	
880005	46,8 mm x 43 mm, 2-farbig "Standarddruck"	Mettler	1250	24
880006	46,8 mm x 62 mm, 2-farbig "Standarddruck"	Mettler	850	24
880007	46,8 mm x 81 mm, 2-farbig "Standarddruck"	Mettler	650	24
880008	46,8 mm x 102 mm, 2-farbig "Standarddruck"	Mettler	500	24
880019	58 mm x 43 mm, blanko	Bizerba	1040	20
880015	58 mm x 60 mm, blanko	Bizerba / Dibal	700	24
880026	58 mm x 60 mm, blanko	Bizerba	850	24
880174	68 mm x 45 mm, blanko	Bizerba	1000	30
880001	49 mm x 40 mm, blanko	Berkel	1000	20
880002	49 mm x 62 mm, blanko	Berkel	650	20
880003	49 mm x 81 mm, blanko	Berkel	500	20
880052	58 mm x 58 mm, blanko	Berkel	500	20
880053	58 mm x 76 mm, blanko	Berkel	400	20



Gut präsentiert und gut sortiert – so verkauft es sich am besten!
 Excellent presentation, Great assortment – Great Sales!





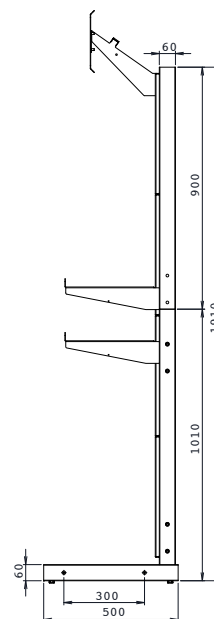
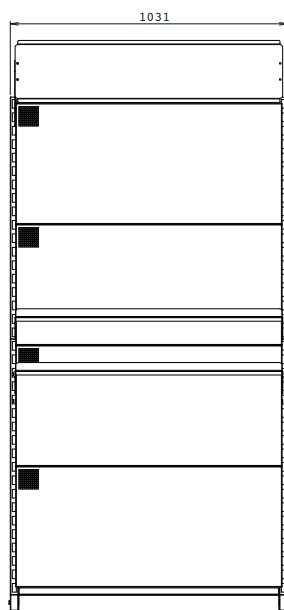
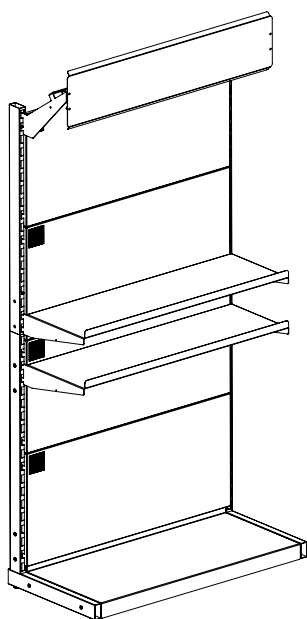

Art.-Nr./code	Beschreibung /description
410300	Grundregal ohne Fachboden und ohne Haken / Basic shelf without shelf and without hooks
410310	1x Fachboden / 1x Shelf 1000 mm x 330 mm
010626	Schlaufen-Haken, Länge 180 mm, 50 Stück = 1 VE / Loop-Hook length 180 mm – 50 pieces = 1 Set
010628	Einfach-Haken, Länge 180 mm, 50 Stück = 1 VE / Single-Hook length 180 mm – 50 pieces = 1 Set





Art.-Nr. / Code	Beschreibung	Description	Größe / Size
460001	Spritzbeutel	Pastry bag	1-28 cm
460002	Spritzbeutel	Pastry bag	2-34 cm
460003	Spritzbeutel	Pastry bag	3-40 cm
460004	Spritzbeutel	Pastry bag	4-46 cm
460005	Spritzbeutel	Pastry bag	5-50 cm
460006	Spritzbeutel-Garnitur 9-tlg.	Pastry bag set 9-pcs.	31 cm
460007	Tüllen-Set Kunststoff, Stern	Star tube set, plastic	3, 5, 7, 9, 11, 13 mm
460008	Tüllen-Set Kunststoff, Loch	Plain tube set, plastic	3, 5, 7, 9, 11, 13 mm
460009	Tüllen-Set Edelstahl, Stern	Star tube set, stainless steel	4, 6, 8, 10, 13, 15 mm
460010	Tüllen-Set Edelstahl, Loch	Plain tube set, stainless steel	4, 6, 8, 10, 13, 15 mm
460011	Stipprolle	Roller docker	12 cm
460012	Gitterschneider	Lattice Cutting Roller	12 cm
460013	Teigschneider	Expandable Dough Cutter	5 x glatt / 5 x plain
460014	Teigschneider	Dough Cutter	Ø 5,5 cm glatt / plain
460017	Stielschaber Silikon	Spatula silicone	28,5 cm
460018	Stielschaber Silikon	Spatula silicone	32,5 cm
460025	Spachtel Edelstahl	Spatula stainless steel	6 cm
460026	Spachtel Edelstahl	Spatula stainless steel	8 cm
460027	Spachtel Edelstahl	Spatula stainless steel	10 cm
460028	Spachtel Edelstahl	Spatula stainless steel	12 cm
460029	Spachtel Edelstahl	Spatula stainless steel	11 x 12 cm
460030	Spachtel Edelstahl	Spatula stainless steel	12 x 12 cm
460031	Spachtel Edelstahl	Spatula stainless steel	13,5 x 13,5 cm
460032	Spachtel Trapez	Spatula Trapez	17 cm
460033	Pinsel Silikon	Brush silicone	5 cm
460034	Pinsel	Brush	4 cm
460035	Pinsel	Brush	5 cm
460036	Pinsel	Brush	6 cm
460037	Pinsel	Brush	7,5 cm
460038	Pinsel Holzgriff, 2-er Set	Brush wood, set à 2	3 + 4 cm
460039	Backmatte	Baking mat	31,5 x 52 cm (GN1/1)
460040	Backmatte	Baking mat	38,5 x 58,5 cm
460047	Schaufel-Set	Set of Scoops	18 cm, 25 cm, 31 cm
460048	Backhandschuh	Baking mitten	34 cm
460049	Tortenspitzen rund	Doilies round	Ø 10 cm
460050	Tortenspitzen rund	Doilies round	Ø 12 cm
460051	Brötchen-Messer- 2er Set	Roll knives-set à 2	18cm
460052	Teigschaber-Set	Dough scraper set	4-teilig / 4 pcs.

MATERIALEIGENSCHAFTEN / MATERIAL CHARACTERISTICS

Material	Eigenschaften	Temperaturbeständigkeit	Material	Characteristics	Temperature resistance
ABS Astyrolacrylbutadiennitril	sehr gute Oberflächenhärte, temperaturwechselfest, spülmaschinenfest	- 35 °C bis ca. + 120 °C	ABS Astyrolacrylbutadiennitril	very hard surface, temperature resistant, dishwasher-proof	- 35 °C up to approx. + 120 °C
EPP Expandiertes Polypropylen	säure- und bruchstabil, geschmacks- und geruchsneutral, spülmaschinenfest	- 40 °C bis ca. + 120 °C	EPP Expanded strong Polypropylene	acid resistant, nearly unbreakable, odourless and detergent resistant, dishwasher-proof	- 40 °C up to approx. + 120 °C
Exoglass	unzerbrechlich, PA 70 %, Glasfaser 30 %, sterilisierbar	bis ca. + 200 °C	Exoglass	unbreakable, PA 70 %, glass fibre 30 % sterilisation possible	approx. + 200 °C
HPE Hochdruck-Polyethylen	weich elastisch, unzerbrechlich, nicht glänzend, kurzzeitig beständig in heissem Wasser	- 40 °C bis ca. + 95 °C	HDPE High Density-Polyethylene	soft-elastic, unbreakable, natural white, short-time stable against boiling water	- 40 °C up to approx. + 95 °C
MF Melamin	sehr hart, kratzfest, sterilisierbar, stoß- und schnittfest, beständig gegen Säure	- 30 °C bis ca. + 70 °C	MF Melamin	very hard, scratch resistance, sterilisation possible, cut and acid-proof	- 30 °C up to approx. + 70 °C
NPE Niederdruck-Polyethylen	hart elastisch, unzerbrechlich, in heissem Wasser ausreichend formbeständig, glänzend	- 40 °C bis ca. + 95 °C	LDPE Low Density-Polyethylene	ard-elastic, unbreakable, resistant and dimensional stable against boiling water, glossy	- 40 °C up to approx. + 95 °C
PA Polyamid	starr, bruch- und schlagfest, mattglänzend	- 40 °C bis ca. + 120 °C	PA Polyamide	stiff, break- and shock-proof, dull gloss	- 40 °C up to approx. + 120 °C
PC Polycarbonat	starr, unzerbrechlich, sehr stabil, in kochendem Wasser formstabil, nicht für Mikrowellen geeignet, sterilisierbar	- 30 °C bis ca. + 135 °C	PC Polycarbonate	stiff, unbreakable, very stable, dimensional stability in boiling water	- 30 °C up to approx. + 135 °C
POM Polyoxymethylen	sehr hart, formbeständig, temperaturwechselfest, spülmaschinenfest	- 40 °C bis ca. + 120 °C	POM Polyacetate	very hard, dimensional and temperature stability, dishwasher-proof	- 40 °C up to approx. + 120 °C
PP Polypropylen 	hart elastisch, unzerbrechlich, formbeständig, in kochendem Wasser, sterilisierbar	- 20 °C bis ca. + 95 °C	PP Polypropylene 	hard-elastic, unbreakable, dimensional stability in boiling water, sterilisation possible	- 20 °C up to approx. + 95 °C
PS Polystyrol 	starr, schlag- und kratzfest, formbeständig, in kochendem Wasser, sterilisierbar	bis ca. + 75 °C	PS Polystyrene 	stiff, shock- and scratch-proof, dimensional stability in boiling water, sterilisation possible	approx. + 75 °C
PTFE Polyamid-tetrafluoroethylene	sehr gute Antihafteigenschaft, lange Lebensdauer, harte Oberfläche, bedingt spülmaschinenfest	- 40 °C bis ca. + 270 °C	PTFE Polyamid-tetrafluoroethylene	excellent non-stick property, long durability, hard surface, limited dishwasher-proof	- 40 °C up to approx. + 270 °C
SAN Styrolacrylnitril	starr, hochglänzend, transparent oder farbig, kratzfest, stoß- und schlagfest	bis ca. + 95 °C	SAN Styrolacrylnitril	stiff, high gloss, transparent or coloured, scratch resistant, shock-proof	approx. + 95 °C
Silikon	sehr empfindliche Oberfläche	bis ca. + 280 °C	Silicone	very sensitive surface	approx. + 280 °C
CNS	Chrom-Nickel-Edelstahl		SST	stainless steel	

(artikelspezifische Abweichungen)

(specific modification)

MATERIALEIGENSCHAFTEN / MATERIAL CHARACTERISTICS

Material	Eigenschaften	Temperaturbeständigkeit	Material	Characteristics	Temperature resistance
PET Polyethylenterephthalat	Ausgezeichnete Dimensionsstabilität, gute Verschleißfestigkeit, spülmaschinenfest	- 20° bis ca. + 110°C	PET Polyethylenterephthalat	Excellent dimensional stability, good wear resistance, dishwasher-safe	- 20 °C up to approx. + 110 °C
PVC Polyvinylchlorid	Hohe Reißfestigkeit, resistent gegen verdünnte Säuren und Laugen, recyclinggerecht	- 20° bis ca. + 100°C	PVC Polyvinylchlorid	High tensile strength, resistant to diluted acids and alkalis, recyclable	- 20 °C up to approx. + 100 °C

WERBEARTIKEL / PROMOTION



Nutzen Sie unser Know-how und unsere Leistungsfähigkeit für Ihre Werbung!

Eine Vielzahl unserer Qualitätsprodukte eignet sich bestens als Werbeträger.

Auf modernen und leistungsfähigen Maschinen können die unterschiedlichsten Materialien durch Prägung, Ätzung oder Druck werbewirksam gestaltet werden.

Somit können wir Ihrem Marketing-Gedanken Rechnung tragen und sind der richtige Partner für Ihre Werbeprodukte.

Bitte fragen Sie uns!

Take advantage of our skills and our efficiency for your advertising!

The majority of our quality products can be used for promotional purposes.

Modern technology enables us to customize your products for advertising by stamping, etching or printing on all kinds of materials.

We are your source for implementing and promoting your marketing ideas.

Please ask for further information!

Es gelten unsere allgemeinen Verkaufs-, Lieferungs- und Zahlungsbedingungen. Technische- und Modelländerungen, Irrtümer, Fehler sowie Verfügbarkeit vorbehalten. Abmessungen, Inhalte, Volumen und Gewichte sind Circa-Angaben.

DE	ARTIKELNUMMERN-INDEX
GB	ITEM NUMBER INDEX
IT	INDICE DEI CODICI DELL'ARTICOLO
ES	INDICE DE CÓDIGOS DE PRODUCTO

Art.-Nr. / code	S. / p.	Art.-Nr. / code	S. / p.	Art.-Nr. / code	S. / p.	Art.-Nr. / code	S. / p.	Art.-Nr. / code	S. / p.
10		111420	127	115091	159	115324	168	116018	332
101000	129	111430	127	115092	159	115325	168	116022	332
101001	129	111440	127	115093	160	115326	168	116026	332
101002	129	111441	127	115094	160	115327	168	116028	332
101003	129	111442	127	115095	173	115328	169	116030	332
101004	129	111443	127	115096	173	115329	169	116033	332
101005	129	113010	339	115097	173	115330	169	116034	332
101006	129	113011	339	115098	161	115331	169	116036	332
101007	129	113020	339	115099	161	115332	169	116038	332
101011	129	113022	339	115131	158	115333	169	116040	332
101040	126	113500	331	115165	163	115334	169	116046	332
101043	126	114001	339	115170	163	115335	169	116100	332
101045	126	114002	339	115184	173	115336	169	116110	332
101050	126	114003	339	115185	173	115338	165	116130	332
101057	126	114021	331	115211	161	115339	165	116210	332
101100	126	114022	331	115212	161	115340	167	116333	332
101120	126	114023	331	115213	161	115341	165	116410	332
101140	126	114024	331	115215	161	115342	166	116430	332
103032	127	114026	331	115217	161	115343	170	116440	332
103040	127	114030	331	115220	157	115344	167	116444	332
103043	127	114050	331	115221	157	115345	167	116450	332
103045	127	114051	331	115222	158	115346	166	116480	332
103050	127	114052	331	115223	162	115347	166	116600	327
103057	127	114053	331	115224	162	115348	170	116610	327
103078	127	114054	331	115225	162	115400	353	116620	327
103100	127	114055	331	115226	157	115401	353	116630	327
103140	127	114056	331	115227	160	115403	353	116640	327
103141	127	114057	331	115228	161	115405	353	116650	327
103150	127	114060	331	115229	162	115406	353	116660	327
105000	29	114061	331	115230	162	115407	353	116670	327
105010	29	115003	157	115231	162	115409	353	116680	327
105020	29	115005	157	115232	162	115412	353	116690	327
106057	127	115006	157	115233	159	115416	353	116700	327
106140	127	115007	157	115250	175	115417	353	116710	327
106152	127	115011	157	115251	175	115418	353	116720	327
107762	130	115012	157	115252	175	115500	177	116730	327
107765	130	115014	158	115253	175	115501	177	116740	327
107780	170	115015	158	115254	175	115530	176	116750	327
107781	170	115016	158	115255	175	115531	176	116760	327
107782	130	115017	158	115256	175	115539	176	116770	327
107783	130	115024	158	115257	175	115540	171	116780	327
107785	130	115028	158	115300	165	115541	171	116790	327
107910	29	115029	158	115301	165	115542	171	116800	327
107911	29	115030	159	115302	165	115543	171	116810	327
107912	29	115036	159	115303	165	115548	171	116820	327
11		115037	159	115304	165	115549	171	116830	327
110100	129	115039	159	115305	165	115800	153	116840	327
110108	129	115043	173	115306	166	115801	153	116850	327
110110	129	115044	173	115307	166	115802	153	116860	327
110116	129	115045	173	115308	166	115803	153	116870	327
110120	129	115046	173	115309	166	115804	153	116880	327
110140	129	115050	173	115310	166	115805	153	116890	327
110150	129	115069	159	115311	166	115806	154	116895	327
110500	129	115071	160	115312	167	115807	154	116896	327
110520	129	115072	160	115313	167	115808	154	116900	327
110540	129	115075	173	115315	167	115809	154	116910	327
110550	129	115076	161	115316	167	115810	155	116920	327
110562	129	115077	162	115317	167	115811	155	116930	327
110700	129	115078	162	115318	167	115812	155	116940	327
110720	129	115086	160	115319	168	115813	155	116950	327
110740	129	115087	160	115320	168	116010	332	116960	327
111300	127	115088	160	115321	168	116013	332	116970	327
111400	127	115089	160	115322	168	116014	332	116980	327
111410	127	115090	159	115323	168	116017	332	116990	327

DE	ARTIKELNUMMERN-INDEX
GB	ITEM NUMBER INDEX
IT	INDICE DEI CODICI DELL'ARTICOLO
ES	INDICE DE CÓDIGOS DE PRODUCTO

Art.-Nr. / code	S. / p.	Art.-Nr. / code	S. / p.	Art.-Nr. / code	S. / p.	Art.-Nr. / code	S. / p.	Art.-Nr. / code	S. / p.
116995	327	122400	133	148004	333	152400	40	152658	264
116996	327	122410	133	148005	333	152401	40	152659	262
12		122420	133	148006	333	152402	40	152660	264
120100	280	122430	133	148007	333	152410	44	152661	262
120108	248	122700	133	148008	333	152411	44	152662	264
120110	248	122710	133	148016	333	152412	44	152663	264
120112	248	122720	133	148020	333	152413	41	152664	264
120114	248	122730	133	148026	333	152414	41	152665	264
120116	248	122740	133	148032	333	152416	41	152666	262
120118	248	122750	133	148040	333	152417	41	152667	265
120190	248	122760	133	148045	333	152420	44	152668	265
120191	248	122770	133	148050	333	152421	44	152669	265
120192	248	122780	133	148051	333	152422	44	152670	265
120193	248	125018	132	149004	334	152430	45	152671	265
120194	248	125025	132	149006	334	152431	45	152672	265
120195	248	125028	132	149007	334	152432	45	152673	265
120200	280	13		149008	334	152450	40	152674	265
120400	281	131030	76	149009	334	152460	43	152675	265
120450	281	131040	76	149010	334	152470	43	152676	265
120520	281	131050	76	149043	334	152480	40	152677	264
120550	279	131060	76	149044	334	152481	40	152679	261
120551	279	131070	76	149045	334	152482	41	152699	261
120552	279	131080	76	149900	342	152490	46	152700	267
120553	279	131800	77	15		152491	46	152710	261
120554	279	131801	77	150000	255	152492	46	152711	261
120555	279	131802	77	150590	35	152495	46	152712	261
120556	279	131812	76	150600	30	152496	46	152840	258
120557	279	131813	76	150610	30	152497	46	152845	258
120640	340	131814	76	150620	42	152541	44	152850	260
120650	281	131815	76	150621	42, 61	152542	44	152851	260
120651	281	131816	76	150625	42, 61	152543	44	152856	260
120653	281	132040	76	150630	42	152544	44	152860	260
120800	201	132070	76	150635	42	152545	45	152861	260
120801	201	132090	76	150640	26	152547	45	152862	260
120802	201	14		150700	32	152600	258	152865	260
120810	201	146003	333	150710	32	152609	258	152880	261
120811	201	146004	333	150720	32	152610	259	152923	47
120812	201	146005	333	150790	33	152611	259	152924	47
122018	132	146006	333	150900	28	152612	259	152933	47
122024	132	146007	333	150910	28	152613	259	152934	47
122035	132	146008	333	150920	28	152630	262	152970	45
122040	132	146030	334	150930	28	152631	262	152971	45
122045	132	146031	334	150930	28	152632	262	152972	45
122050	132	146040	334	151065	63	152633	263	152975	31
122055	132	146050	335	151066	63	152635	263	153000	267
122060	132	146051	335	151140	49	152636	263	153001	267
122065	132	146052	335	151170	62	152637	263	153090	37
122070	132	146060	335	151171	62	152638	263	153091	37
122075	132	146070	336	151172	62	152639	263	153092	37
122080	132	146071	336	151175	62	152640	263	153100	206
122100	133	146072	336	151190	62	152641	263	153110	206
122105	133	146072	336	151195	49	152642	263	153200	206
122110	133	146100	335	151200	266	152643	263	153204	206
122110	133	146110	335	151230	266	152643	263	153204	206
122250	132	146120	335	151235	266	152644	263	153210	206
122260	131	146130	336	151300	255	152645	263	153300	206
122270	132	147000	24	151301	255	152646	263	153351	246
122271	132	147010	25	151400	309	152647	263	153352	246
122272	132	147020	25	151410	309	152648	263	153400	206
122273	132	147030	25	151420	309	152652	262	153450	206
122274	132	147100	26	151430	309	152653	262	153451	206
122275	132	147105	26	151432	309	152654	263	153452	206
122276	132	148001	333	151450	309	152655	264	153500	246
122277	132	148002	333	151460	309	152656	264	153510	246
122278	132	148003	333	151500	308	152657	262	153550	246

DE	ARTIKELNUMMERN-INDEX
GB	ITEM NUMBER INDEX
IT	INDICE DEI CODICI DELL'ARTICOLO
ES	INDICE DE CÓDIGOS DE PRODUCTO

Art.-Nr. / code	S. / p.	Art.-Nr. / code	S. / p.	Art.-Nr. / code	S. / p.	Art.-Nr. / code	S. / p.	Art.-Nr. / code	S. / p.
153560	246	154074	321	155300	52, 244	156017	241	158320	77
153570	64	154080	321	155310	52, 244	156075	53, 247	158330	77
153600	38, 39	154081	321	155320	52, 244	156076	53, 247	158410	77
153601	39	154082	321	155330	52, 244	156110	115	158420	77
153602	39	154083	321	155331	52, 244	156111	115	159130	128
153603	39	154084	321	155332	52, 244	156112	115	159150	128
153604	39	154086	110	155340	52, 244	156113	115	159160	128
153610	38, 39	154087	110	155341	52, 244	156115	249	159230	128
153620	38, 39	154088	110	155342	52, 244	156116	249	159240	128
153640	27	154089	321	155350	52, 244	156124	249	159250	128
153650	27	154090	329	155351	52, 244	156125	249	159260	128
153900	74	154091	329	155352	52, 244	156126	249	159350	128
153901	74	154093	329	155356	245	156128	249	159360	128
153902	74	154094	329	155357	245	156129	249	159450	128
153903	74	154095	320	155360	245	156130	249	159460	128
153904	74	154096	320	155361	245	156131	249	159700	81
153905	74	154097	320	155362	245	156165	241	159701	81
153906	74	154098	320	155363	245	156185	241	159702	81
153908	74	154099	320	155364	245	156186	241	159900	27
153909	74	154104	204	155365	245	156187	241	16	
153935	74	154203	205	155366	245	156205	241	160001	270
153950	229	154300	204	155367	245	156206	241	160002	270
153960	75	154420	205	155368	245	156207	241	160003	270
153961	75	154421	205	155369	245	156225	241	160004	270
153970	349	154422	205	155370	245	156226	241	160005	270
153975	349	154424	205	155371	245	156227	241	160006	272
153976	349	154427	205	155372	245	156241	242	160012	270
154001	328	154429	205	155373	245	156245	241	160014	269
154002	328	154430	205	155374	245	156246	241	160018	273
154003	328	154499	205	155375	245	156247	241	160019	269
154004	328	154702	46	155376	245	156261	242	160026	271
154010	328	154710	47	155377	245	156265	241	160028	271
154020	328	154711	47	155378	245	156266	241	160029	272
154021	323	154712	47	155379	245	156267	241	160034	271
154024	323	154720	47	155380	246	156281	242	160035	271
154025	323	154721	47	155381	246	156282	242	160036	271
154026	323	154722	47	155382	246	156285	241	160050	268
154028	323	154810	94	155383	246	156286	241	160051	269
154030	323	154812	340	155384	246	156287	241	160052	272
154031	323	154813	81	155385	246	156301	242	160053	273
154032	323	154840	213	155386	246	156302	242	160054	273
154033	323	154841	213	155387	246	156321	242	161020	268
154034	323	154842	213	155388	246	156322	242	161030	268
154040	323	155009	182	155389	246	156753	241	162080	240
154041	323	155010	182	155390	246	156754	241	162100	240
154042	323	155011	182	155391	246	156853	241	162120	240
154043	323	155040	323	155399	246	156953	241	162140	240
154050	321	155041	323	155400	245	157000	288	162160	240
154051	321	155042	323	155410	245	157001	288	162180	240
154052	321	155043	323	155420	245	157002	288	162200	240
154053	321	155050	243	155430	245	157010	242	162220	240
154054	321	155051	243	155450	53, 247	157760	31	162240	240
154055	321	155060	52, 244	155451	53, 247	157770	31	162260	240
154056	321	155070	243	155452	53, 247	157950	78	162280	240
154059	321	155071	243	155453	53, 247	157960	78	162300	240
154060	320	155072	243	155454	53, 247	158006	200	162320	240
154061	320	155073	243	155455	53, 247	158010	77	162340	240
154062	320	155074	243	155456	53, 247	158020	77	163075	240
154065	329	155100	52, 244	155500	238	158110	77	163080	240
154066	329	155110	52, 244	156008	132	158120	77	163120	240
154070	321	155120	52, 244	156009	132	158130	77	163140	240
154071	321	155200	52, 244	156013	241	158210	77	163160	240
154072	321	155210	52, 244	156014	241	158220	77	163180	240
154073	321	155220	52, 244	156015	241	158310	77	163200	240

DE	ARTIKELNUMMERN-INDEX
GB	ITEM NUMBER INDEX
IT	INDICE DEI CODICI DELL'ARTICOLO
ES	INDICE DE CÓDIGOS DE PRODUCTO

Art.-Nr. / code	S. / p.	Art.-Nr. / code	S. / p.	Art.-Nr. / code	S. / p.	Art.-Nr. / code	S. / p.	Art.-Nr. / code	S. / p.
163220	240	166140	252	170141	230	180220	235	190153	384
163240	240	166500	51	170145	230	180230	235	190154	384
163260	240	166501	51	170146	230	180240	235	190155	384
163280	240	166502	51	170147	230	180250	235	190156	384
163300	240	166503	51	170148	230	180260	235	190159	384
164120	240	166504	51	171000	342	180270	235	190200	382
164140	240	166505	51	171001	342	180280	235	190210	382
164160	240	166506	51	171002	342	180300	235	190220	382
164180	240	166507	51	171003	342	180310	235	190230	382
164200	240	166508	51	171004	342	180320	235	190240	382
164220	240	166509	51	171005	342	180330	235	190250	382
164240	240	17		171020	343	180340	235	190300	385
164260	240	170010	71, 223	171030	343	180350	235	190305	385
164280	240	170011	71, 223	171040	341	180360	235	190308	385
164300	240	170012	71, 223	171041	341	180370	235	190310	385
166001	190	170013	71, 223	171042	341	180400	235	191011	60
166002	190	170014	71, 223	171050	341	180410	235	191012	60
166003	190	170015	71, 223	171051	341	180420	235	191013	60
166004	190	170016	70, 222	171052	341	180430	235	191091	198
166005	190, 191	170040	70, 222	172000	339	180440	235	191093	198
166006	190, 191	170041	70, 222	172001	339	180450	235	191120	60
166007	190, 191	170042	70, 222	172002	339	180460	235	191121	60
166008	190, 191	170043	70, 222	172003	339	181014	254	193030	50
166009	190, 191	170044	70, 222	172100	385	181100	254	193031	50
166010	190, 191	170050	71, 223	172101	385	181160	254	193032	50
166022	190	170051	71, 223	172200	386	181170	254	193033	50
166023	190	170052	71, 223	172201	386	181200	254	193040	50
166024	190	170053	71, 223	172202	386	182000	254	193041	50
166025	190, 191	170054	71, 223	172203	386	182005	254	195010	383
166026	190, 191	170070	71, 223	172204	386	182010	254	195015	383
166027	190, 191	170071	71, 223	172300	386	182020	254	195020	383
166028	190, 191	170072	71, 223	172370	54, 343	182030	254	195025	383
166029	190, 191	170073	71, 223	172371	54	19		195030	383
166030	190, 191	170074	71, 223	172401	340	190000	384	195035	383
166031	190, 191	170075	71, 223	172413	343	190002	384	195040	383
166032	190, 191	170079	71, 223	172414	343	190004	384	195045	383
166033	190, 191	170080	70, 222	172415	343	190006	384	195050	383
166034	190, 191	170081	70, 222	172416	343	190008	384	195055	383
166035	190, 191	170082	70, 222	172420	344	190010	384	195060	383
166036	190, 191	170083	70, 222	172430	345	190011	384	195100	382
166037	190, 191	170084	70, 222	172460	54	190012	384	195110	382
166080	199	170085	70, 222	172461	54	190014	384	195120	382
166081	199	170101	231	172462	54	190015	384	195130	382
166082	199	170107	231	172463	54	190016	384	195140	382
166083	199	170108	231	172464	54	190017	384	195150	382
166084	199	170109	231	172465	54	190018	384	195180	382
166085	199	170110	231	172466	54	190019	384	195190	382
166086	199	170111	231	172500	329	190020	384	195210	382
166087	199	170112	231	172510	329	190022	384	195220	382
166088	199	170113	231	172520	328	190120	384	195230	382
166100	178, 179	170114	231	172530	328	190130	384	195250	382
166101	178, 179	170115	231	172600	344	190132	384	195260	382
166102	178, 179	170116	231	172610	344	190133	384	195290	382
166103	178, 179	170117	231	172630	344	190135	384	195400	383
166104	178, 179	170118	231	172640	344	190137	384	195405	383
166105	178, 179	170119	231	172650	345	190139	384	195410	383
166106	178, 179	170120	230	172660	345	190140	384	195415	383
166107	178, 179	170121	230	172670	345	190142	384	195420	383
166108	178, 179	170135	230	172680	345	190144	384	195425	383
166109	178, 179	170136	230	172700	330	190146	384	195430	383
166110	178	170137	230	172710	330	190148	384	195435	383
166120	178, 179	170138	230	18		190150	384	195440	383
166121	178, 179	170139	230	180202	235	190151	384	195450	383
166130	252	170140	230	180210	235	190152	384	195700	386

DE	ARTIKELNUMMERN-INDEX
GB	ITEM NUMBER INDEX
IT	INDICE DEI CODICI DELL'ARTICOLO
ES	INDICE DE CÓDIGOS DE PRODUCTO

Art.-Nr. / code	S. / p.	Art.-Nr. / code	S. / p.	Art.-Nr. / code	S. / p.	Art.-Nr. / code	S. / p.	Art.-Nr. / code	S. / p.
196000	36	197332	297	197557	294	198821	56	199054	236
196010	36	197333	296	197558	294	198822	56	199055	236
196015	36	197334	296	197559	294	198823	56	199056	236
196020	36	197335	296	197560	294	198824	56	199057	236
196030	36	197336	296	197561	294	198825	56	199058	236
196500	306	197337	296	197562	294	198840	57	199059	61
196501	306	197340	297	197563	294	198841	57	199060	61
196502	306	197350	293	197564	294	198860	58	199061	61
196503	306	197400	298	197565	294	198861	58	199063	61
196504	306	197401	298	197566	294	198870	58	199064	61
196505	306	197402	298	197570	301	198871	58	199065	61
196506	306	197403	300	197571	301	198872	58	199069	236
196507	306	197405	298	197572	301	198873	58	199070	213
196520	306	197406	298	197573	301	198874	58	199075	213
196521	306	197407	298	197574	301	198875	58	199095	56
196522	306	197408	298	197575	301	198880	56	199096	56
196523	306	197409	298	197576	302	198881	56	199120	350
196524	306	197410	298	197577	302	198882	56	199121	350
196525	306	197411	299	197578	302	198883	56	199122	350
196526	306	197412	299	197579	302	198890	59	199123	350
196527	306	197413	299	197580	302	198891	59	199124	350
196528	306	197414	299	197581	302	198892	59	199125	350
196530	306	197415	299	197582	302	198900	340	199126	350
196540	306	197417	299	197583	302	198901	340	199128	350
196550	307	197418	299	197584	302	198902	340	199129	350
196560	307	197419	299	197595	293	198903	340	199130	350
196570	307	197420	299	198000	253	198904	340	199150	192, 193
196580	307	197421	300	198001	253	198905	340	199160	243
196600	304, 305	197422	300	198002	253	198910	340	199161	243
196610	304, 305	197423	300	198003	253	198911	340	199162	243
196620	304, 305	197424	300	198004	253	198912	340	199163	194, 195
196630	304, 305	197425	300	198005	253	198913	340	199164	194, 195
196660	303	197426	300	198006	253	198914	340	199165	194, 195
197032	303	197427	300	198007	253	198915	340	199166	194, 195
197033	303	197428	300	198008	253	199000	69, 226	199167	194, 195
197060	303	197429	301	198009	253	199002	69, 226	199168	194, 195
197136	294	197430	301	198010	253	199003	69, 226	199169	194, 195
197180	295	197500	295	198012	253	199004	69, 226	199170	194, 195
197300	297	197501	295	198013	253	199005	69, 226	199171	196, 197
197301	297	197502	295	198014	253	199006	69, 226	199172	196, 197
197302	297	197503	295	198015	253	199007	69, 226	199173	186, 187
197303	301	197504	295	198017	253	199008	69, 226	199174	186, 187
197310	296	197505	295	198021	55	199009	69, 226	199175	186, 187
197311	296	197506	295	198022	55	199010	69, 226	199176	186, 187
197312	296	197507	295	198030	55	199011	69, 226	199177	186, 187
197313	296	197508	295	198032	55	199012	69, 226	199178	186, 187
197314	296	197509	295	198033	55	199013	69, 226	199179	186, 187
197315	296	197510	295	198040	55	199014	69, 226	199180	186, 187
197316	296	197511	295	198041	55	199015	69, 226	199181	186, 187
197317	296	197512	295	198042	55	199017	69, 226	199182	186, 187
197318	296	197513	295	198043	55	199018	69, 226	199183	186, 187
197319	296	197514	295	198050	55	199019	69, 226	199184	186, 187
197320	296	197515	295	198051	55	199026	61	199210	237
197321	296	197516	295	198060	54	199027	61	199211	237
197322	296	197517	295	198061	54	199028	61	199212	237
197323	296	197518	295	198801	56	199030	342	199220	237
197324	296	197519	295	198802	56	199031	65	199221	237
197325	296	197550	294	198803	56	199032	65	199222	237
197326	296	197551	294	198804	56	199033	350	199223	237
197327	296	197552	294	198805	56	199034	350	199321	58
197328	296	197553	294	198806	56	199035	342	199328	57
197329	296	197554	294	198807	56	199036	342	199329	57
197330	297	197555	294	198808	56	199052	236	199330	57
197331	297	197556	294	198820	56	199053	236	199331	57

DE	ARTIKELNUMMERN-INDEX
GB	ITEM NUMBER INDEX
IT	INDICE DEI CODICI DELL'ARTICOLO
ES	INDICE DE CÓDIGOS DE PRODUCTO

Art.-Nr. / code	S. / p.	Art.-Nr. / code	S. / p.	Art.-Nr. / code	S. / p.	Art.-Nr. / code	S. / p.	Art.-Nr. / code	S. / p.
199361	64	199584	188	199883	192, 193	200164	208	200348	234
199362	64	199585	198	199884	192, 193	200165	208	200349	234
199363	64	199586	198	199885	192, 193	200166	208	200350	234
199364	65	199590	200	199886	194, 195	200170	68, 232	200351	234
199365	65	199591	200	199887	192, 193	200179	68, 232	200352	234
199370	57	199610	387	199888	192, 193	200182	204	200353	234
199371	57	199611	387	199890	192, 193	200190	337	200354	234
199372	57	199612	387	199891	192, 193	200192	229	200355	234
199373	57	199613	387	199892	49	200194	229	200420	216
199374	57	199614	387	199893	49	200195	229	200421	216
199375	57	199615	387	199894	49	200196	229	200422	216
199380	58	199616	387	199895	49	200197	229	200423	216
199381	58	199617	387	199920	34	200200	202	200424	216
199382	58	199618	387	199950	34	200201	202	200490	61
199383	58	199619	387	199960	252	200202	202	200491	61
199384	58	199620	387	199986	243	200203	202	200492	61
199400	227	199621	387	199987	243	200204	202	200493	61
199401	227	199622	387	199988	243	200205	202	200494	61
199402	227	199623	387	199999	34	200206	202	200495	61
199403	227	199624	387	20		200207	202	200496	61
199404	227	199629	387	200001	204	200208	202	200500	60, 214
199405	227	199630	387	200002	204	200209	202	200501	60, 214
199406	227	199640	183	200003	204	200210	202	200502	60, 214
199409	50	199641	183	200004	205	200212	202	200503	60, 214
199410	50	199642	183	200005	82, 207	200213	202	200504	60, 214
199411	50	199643	183	200006	82, 207	200214	202	200510	82, 207
199412	50	199650	184, 185	200007	82, 207	200215	202	200511	82, 207
199420	226	199651	184, 185	200010	68, 232	200216	202	200512	82, 207
199421	226	199652	184, 185	200011	68, 232	200217	202	200515	82, 207
199422	226	199653	184, 185	200012	68, 232	200218	202	200516	82, 207
199423	226	199654	184, 185	200013	68, 232	200219	202	200517	82, 207
199424	226	199655	184, 185	200014	68, 232	200234	201	200600	213
199425	226	199656	183	200015	68, 232	200235	201	200601	213
199500	180, 181	199657	183	200022	67, 224, 225	200236	201	200602	213
199501	180, 181	199658	183	200023	234	200237	201	200610	214, 351
199502	180, 181	199659	184, 185	200024	234	200238	201	200611	214, 351
199503	180, 181	199660	184, 185	200025	234	200239	201	200620	214
199504	180, 181	199661	184, 185	200026	234	200240	237	200621	214
199505	180, 181	199662	184, 185	200027	234	200241	237	200622	214
199506	180, 181	199663	184, 185	200096	209	200245	293	200625	82
199507	180, 181	199700	192, 193	200097	209	200260	201	200626	82
199508	180, 181	199710	192, 193	200102	337	200261	201	200627	82
199510	180, 181	199720	192, 193	200103	337	200271	202	200630	237
199511	180, 181	199730	192, 193	200104	337	200272	202	200631	237
199512	182	199740	192, 193	200105	337	200273	202	200632	237
199513	182	199750	192, 193	200106	337	200274	202	200633	237
199520	182	199760	194, 195	200108	337	200275	202	200634	237
199530	188	199761	194, 195	200109	337	200276	202	200635	236
199540	189	199770	194, 195	200114	205	200280	202	200640	79
199541	189	199780	196, 197	200115	82, 207	200285	203	200641	79
199542	189	199790	196, 197	200116	82, 207	200286	203	200642	79
199543	189	199800	196, 197	200123	209	200287	203	200643	79
199544	189	199820	196, 197	200124	209	200288	203	200644	83
199545	189	199830	196, 197	200125	209	200290	203	200646	81
199546	189	199840	196, 197	200126	209	200291	203	200647	79
199547	189	199850	196, 197	200127	209	200292	203	200700	214
199548	189	199851	192	200128	209	200293	203	200701	214
199549	189	199852	192	200129	209	200299	202	200702	213
199570	196, 197	199853	192	200149	68, 232	200300	237	200703	213
199571	196, 197	199860	196, 197	200150	68, 232	200301	237	200710	214, 351
199580	199	199870	196, 197	200160	208	200312	202	200750	215
199581	199	199880	192, 193	200161	208	200313	202	200751	215
199582	199	199881	192, 193	200162	208	200346	234	200752	215
199583	199	199882	192, 193	200163	208	200347	234	200760	215

DE	ARTIKELNUMMERN-INDEX
GB	ITEM NUMBER INDEX
IT	INDICE DEI CODICI DELL'ARTICOLO
ES	INDICE DE CÓDIGOS DE PRODUCTO

Art.-Nr. / code	S. / p.	Art.-Nr. / code	S. / p.	Art.-Nr. / code	S. / p.	Art.-Nr. / code	S. / p.	Art.-Nr. / code	S. / p.
200761	215	201330	218, 219	202405	338	206010	68, 232	226750	317
200762	215	201400	218, 219	202406	338	206011	68, 232	226850	317
200770	216	201410	218, 219	202407	338	206012	68, 232	226860	317
200771	216	201420	218, 219	202408	338	206013	68, 232	226870	317
200772	216	201430	218, 219	202409	338	206014	68, 232	226880	317
200773	216	201440	218, 219	202410	338	206015	68, 232	226890	317
200802	234	201450	218, 219	202411	338	206112	68, 232	227001	216
200830	112	201451	218, 219	202412	338	206113	68, 232	227002	216
200840	112	201500	218, 219	202413	338	22		227003	318
200850	112	201510	218, 219	202414	338	220108	248	227004	318
200855	112	201520	218, 219	203110	242	220110	248	227007	318
200860	112	201600	218, 219	203111	242	220112	248	227008	318
200865	112	201610	218, 219	203112	242	220114	248	227009	318
200870	112	201620	218, 219	203113	242	220116	248	227010	318
200875	112	201630	218, 219	203114	242	220118	248	227011	318
200880	112	201700	218, 219	203115	242	220119	248	227012	318
200881	112	201710	218, 219	203116	242	220120	248	227013	318
200882	112	201720	218, 219	203117	242	220122	248	227014	318
200890	111	201730	218, 219	203210	72	220124	248	227015	318
200891	111	201800	218, 219	203211	72	220126	248	227016	318
200892	111	201810	218, 219	203212	72	220128	248	227023	320
200893	111	201820	218, 219	203220	72	221020	225	227024	320
200899	200	201830	218, 219	203230	72	221021	225	227025	324
200900	200	201850	218, 219	203300	208	221022	225	227026	324
200915	200	201851	218, 219	203310	208	221023	225	227027	324
200925	215	201852	218, 219	203400	238	221024	225	227028	325
200926	215	201901	220	203401	238	221025	225	227029	324
200927	215	201902	220	203402	238	221026	67, 225	227031	330
200928	215	201903	220	203403	238	226050	315	227040	326
200929	215	201904	220	203404	238	226060	315	227094	318
200930	217	201905	220	203405	238	226070	315	227095	318
200931	217	201906	220	203406	238	226080	315	227096	318
200932	217	201907	220	203407	238	226090	315	227097	318
200933	217	202000	113	203408	238	226120	315	227098	320
200934	217	202005	113	203409	238	226130	315	227099	136, 216
200935	217	202010	113	203410	238	226140	315	227100	250
200950	53, 247	202015	113	203411	79, 239	226150	315	227125	324
200960	112, 225	202020	113	203412	79, 239	226250	315	227126	324
200962	112, 225	202025	113	203413	79, 239	226260	315	227127	324
200963	112, 121	202030	113	203414	79, 239	226270	315	227128	325
200970	112, 225	202035	113	203415	79, 239	226280	315	227129	324
200971	112, 225	202090	128	203416	79, 239	226290	315	227130	21, 319
201000	221	202091	128	203417	79, 239	226350	316	227131	21, 319
201005	221	202092	106, 121	203418	79, 239	226360	316	227132	21, 319
201010	221	202093	121	203419	239	226370	316	227133	21, 319
201015	221	202095	121	203420	239	226380	316	227134	21, 319
201020	221	202098	113	203421	239	226390	316	227135	21, 319
201025	221	202099	106, 121	203422	239	226420	316	227136	21, 319
201030	221	202100	113	203423	217	226430	316	227137	21, 319
201035	221	202110	113	203424	217	226440	316	227138	21, 319
201040	221	202120	113	203425	217	226450	316	227139	21, 319
201045	221	202170	83	203426	217	226550	316	227140	21, 319
201050	221	202171	83	203427	217	226560	316	227141	21, 319
201055	221	202172	83	203428	217	226570	316	227142	21, 314, 319
201100	337	202173	83	203429	217	226580	316	227144	314
201120	337	202294	203	203430	217	226590	316	227150	330
201200	218, 219	202295	203	203431	217	226650	317	227160	330
201210	218, 219	202296	203	203432	217	226660	317	227170	330
201220	218, 219	202297	203	203433	217	226670	317	227180	330
201230	218, 219	202400	338	203434	217	226680	317	227200	250
201300	218, 219	202401	338	203435	217	226690	317	227220	292, 325
201302	218, 219	202402	338	203436	217	226720	317	227225	324
201310	218, 219	202403	338	203437	217	226730	317	227227	324
201320	218, 219	202404	338	203438	239	226740	317	227229	324

DE	ARTIKELNUMMERN-INDEX
GB	ITEM NUMBER INDEX
IT	INDICE DEI CODICI DELL'ARTICOLO
ES	INDICE DE CÓDIGOS DE PRODUCTO

Art.-Nr. / code	S. / p.	Art.-Nr. / code	S. / p.	Art.-Nr. / code	S. / p.	Art.-Nr. / code	S. / p.	Art.-Nr. / code	S. / p.
227230	211	228211	251	260031	100	260800	96	262602	88
227231	211	228300	104	260032	100	260801	96	262612	88
227232	211	228301	104	260033	100	260802	96	262616	88
227233	211	228302	104	260034	100	260803	96	262621	88
227235	211	228303	104	260035	100	260804	96	262626	88
227240	210	228304	104	260040	101	260805	96	262631	88
227241	210	228305	104	260041	101	260806	96	262636	31, 88
227242	210	228310	104	260042	101	260807	96	262640	88
227243	210	228311	104	260043	101	260810	97	262712	89
227244	210	228312	104	260044	101	260811	96	262721	89
227246	212	228313	104	260050	101	260812	96	262726	89
227247	212	228314	104	260099	102	260813	96	262731	89
227350	211	228315	104	260500	92	260814	96	262736	89
227351	211	228316	104	260501	92	260815	96	262825	89
227352	211	228330	105	260502	92	260816	98	262901	89
227355	211	228331	105	260510	92	260817	98	262902	89
227356	211	228340	105	260511	92	260818	98	262903	89
227360	211	23		260512	92	260819	98	262904	89
227363	211	230020	228	260520	92	260820	98	264026	85
227364	211	230021	228	260521	92	260830	97	264031	85
227365	211	230030	351	260522	92	260831	97	264036	85
227550	329	230040	228	260530	92	260832	97	264131	85
227551	329	230041	228	260531	92	260833	97	264136	85
227600	322	230042	228	260532	92	260834	97	264226	85
227601	322	230043	228	260540	92	260835	97	264231	85
227610	322	230044	228	260541	92	260836	97	264236	85
227611	322	230045	228	260542	92	260837	97	264331	85
227620	322	230100	228	260550	92	260838	97	264336	85
227621	322	230110	228	260551	92	260839	97	264431	85
227622	322	230120	228	260552	92	260840	97	264436	85
227630	322	230130	228	260560	92	260841	97	264531	85
227640	322	230150	69	260561	92	260850	98	264536	85
227650	329	230160	69	260570	92	260860	99	264631	85
227651	329	25		260571	92	260861	99	264636	85
227750	212	250001	233	260580	93	260862	99	264731	85
227752	212	250002	233	260582	93	260863	99	264736	85
227756	212	250003	233	260590	93	260864	99	264831	85
227757	212	250004	233	260592	93	260865	99	264836	85
227763	212	250005	233	260600	93	260868	62	264931	86
227850	212	250006	233	260610	90	260869	62	265023	86
227852	212	250007	233	260611	90	260876	99	265028	86
227856	212	250008	233	260612	90	260877	99	265123	86
227857	212	250009	233	260630	90	260878	99	265128	86
227863	212	250100	60	260631	90	260880	95	265223	86
228101	250	255000	352	260632	90	260881	95	265228	86
228102	250	255250	348	260640	90	260884	95	265326	86
228103	251	255260	348	260641	90	260890	95	265426	87
228104	251	255270	348	260642	90	260900	102	265431	87
228109	251	255280	348	260650	91	260901	102	265436	87
228128	59	255290	348	260651	91	260902	102	265526	87
228129	59	255320	346	260652	91	260903	102	265531	87
228130	105	255350	346	260670	95	260905	102	265536	87
228131	105	255400	349	260671	95	260906	102	265626	87
228200	251	255420	349	260672	95	260907	102	265631	87
228201	251	256000	352	260673	95	260910	103	265636	87
228202	251	256100	352	260700	98	261800	94	265826	87
228203	251	256200	352	260701	98	261810	94	265921	87
228204	251	256300	352	260702	98	262350	84	265926	87
228205	251	26		260703	98	262360	84	266000	308, 310
228206	251	260000	100	260720	91	262436	84	266002	310
228207	251	260010	100	260730	91	262518	88	266003	310
228208	251	260020	101	260740	93	262522	88	266004	310
228209	251	260021	101	260742	93	262600	88	266006	310
228210	251	260030	100	260750	95	262601	88	266007	308, 310

DE	ARTIKELNUMMERN-INDEX
GB	ITEM NUMBER INDEX
IT	INDICE DEI CODICI DELL'ARTICOLO
ES	INDICE DE CÓDIGOS DE PRODUCTO

Art.-Nr. / code	S. / p.	Art.-Nr. / code	S. / p.	Art.-Nr. / code	S. / p.	Art.-Nr. / code	S. / p.	Art.-Nr. / code	S. / p.
266009	310	280078	109	33		381051	117	391880	291
266010	310	280100	110	330002	284	381052	117	391900	292
266011	310	280101	110	330003	284	381054	117	391901	292
266012	310	281001	109	330004	284	381057	117	391902	292
266013	310	281002	109	330005	284	381058	117	391950	123
266112	310	281003	109	330007	284	381100	118	391951	123
266113	310	281004	109	35		381101	118	391952	123
266400	311	281005	109	350080	285	381102	118	391953	123
266401	311	281006	109	350081	285	381108	118	391954	123
266404	311	281007	109	350082	285	381109	118	391960	123
266405	311	281008	109	350083	285	381110	118	391961	123
266406	311	281009	109	350084	285	381150	131	391970	123
266407	311	281010	109	350085	285	381151	131	391971	123
266409	311	281011	109	350086	285	381200	119	391972	123
266450	311	281012	109	350087	285	381201	119	391980	123
266452	311	281013	109	350088	285	381400	120	42	
266454	311	281014	109	350089	285	381401	120	421002	375
266455	311	281015	109	350090	285	381410	120	421003	375
266500	312	281020	341	350144	287	381420	120	421006	365
266501	312	281021	341	350145	287	381421	120	421012	355
266502	312	29		350147	293	381422	120	421015	363
266503	312	290000	66, 224	350170	285	382000	117	421019	364
266504	312	290010	66, 224	350171	285	382010	117	421023	355
266505	312	290020	66, 224	350172	285	382020	117	421024	368
266550	312	290030	66, 224	350173	285	382030	117	421025	368
266551	312	290040	66, 67, 224	350174	285	382040	117	421027	363
266554	312	290050	66, 224	350175	285	382100	118	421028	371
266555	312	290070	66, 224	350176	285	382110	118	421031	368
266600	313	290071	66, 224	350177	285	382200	119	421033	361
266610	313	290072	66, 224	350178	285	382500	114	421036	368
266620	313	290073	66, 224	350179	285	382501	114	421037	362
266800	312	290074	66, 224	350180	285	382502	114	421045	368
266960	31, 130	290075	66, 224	350199	289	382510	114	421046	363
27		290150	63	350250	286	382511	114	421048	361
270000	103	290200	67, 227, 351	350251	286	382512	114	421050	357
270001	103	290300	67	350252	286	382520	114	421053	357
270002	103	292000	48	350253	286	382521	114	421058	361
270003	103	292001	48	350254	286	382522	114	421078	360
270004	103	292002	48	350255	286	382530	115	421079	360
270005	103	292003	48	350256	286	382531	115	421081	368
270006	103	292004	48	350257	286	382532	115	421082	368
28		292005	48	350258	286	385000	122	421084	380
280011	106	292006	48	350259	286	385010	122	421089	363
280012	106	292007	48	350260	286	385020	122	421092	371
280013	106	292008	48	350600	287	385030	122	421093	363
280014	106	31		350601	287	39		421094	368
280016	106	310001	274	350650	287	391050	289	421095	363
280019	106	310002	274	351400	286	391200	290	421104	363
280020	107	310003	274	351401	286	391210	290	421129	365
280021	107	310004	275	351402	286	391220	290	421132	378
280030	108	310019	275	351403	286	391230	290	421134	361
280031	108	310023	276	351404	286	391240	290	421145	356
280032	108	310024	276	351405	286	391320	291	421146	356
280033	108	310027	277	351406	286	391330	291	421147	356
280034	108	310030	276	351407	286	391400	290	421148	356
280039	108	310031	73, 277	351408	286	391410	290	421156	371
280040	83, 108	310032	73, 277	351409	286	391510	278	421157	376
280041	83, 108	310080	275	351410	286	391530	278	421158	375
280042	83, 108	310082	275	38		391535	278	421170	380
280050	109	310083	275	381000	119	391550	278	421173	371
280051	109	310085	73, 277	381005	119	391800	290	421189	368
280070	110	310090	276	381006	119	391810	290	421191	363
280075	109	310099	73, 277	381007	119	391820	290	421197	361
280076	109	310111	276	381050	117	391850	289	421209	359

DE	ARTIKELNUMMERN-INDEX
GB	ITEM NUMBER INDEX
IT	INDICE DEI CODICI DELL'ARTICOLO
ES	INDICE DE CÓDIGOS DE PRODUCTO

Art.-Nr. / code	S. / p.	Art.-Nr. / code	S. / p.	Art.-Nr. / code	S. / p.	Art.-Nr. / code	S. / p.	Art.-Nr. / code	S. / p.
421214	355	421516	357	421779	369	421930	374	530015	16
421216	356	421517	355	421780	372	421931	365	530020	16
421217	375	421519	361	421781	369	421932	374	530021	16
421218	356	421521	371	421782	373	421933	365	530022	16
421219	362	421526	355	421784	370	421934	365	530023	16
421224	366	421529	364	421786	358	421935	374	530025	16
421225	368	421533	369	421794	370	421936	374	530030	16
421226	363	421537	357	421795	367	421937	355	530031	16
421251	357	421540	364	421796	378	421938	365	530032	16
421252	357	421544	371	421797	376	421939	374	530033	16
421253	357	421545	371	421799	370	422009	369	530035	16
421254	357	421554	359	421826	361	422018	367	530040	16
421255	358	421555	372	421830	361	422022	376	530041	16
421256	378	421558	364	421840	370	422037	359	530042	16
421258	375	421559	372	421842	370	422038	360	530043	16
421263	368	421561	362	421847	367	422054	367	530045	16
421266	357	421564	372	421848	370	422110	379	530050	16
421280	355	421568	361	421853	367	422116	376	530051	16
421289	362	421575	372	421854	378	422121	356	530055	16
421290	362	421576	356	421858	370	422122	356	530060	16
421291	376	421582	358	421859	370	422162	379	530061	16
421292	376	421585	375	421865	367	422169	369	530062	16
421294	380	421586	380	421866	370	422251	376	530063	16
421296	355	421588	378	421867	377	422252	376	530064	16
421297	355	421597	367	421868	360	422253	377	530100	17
421300	362	421611	378	421869	360	422254	377	530101	17
421301	368	421612	379	421870	360	422276	379	530102	17
421302	360	421617	372	421872	378	422295	377	530103	17
421317	357	421622	370	421873	358	422343	363	530105	17
421321	367	421623	380	421874	365	422360	367	530110	17
421327	364	421628	366	421877	364	422361	376	530111	17
421330	371	421630	372	421878	360	422370	364	530112	17
421333	360	421635	359	421880	364	422371	373	530113	17
421342	375	421637	361	421883	370	422391	374	530115	17
421354	380	421638	369	421885	370	422392	372	530120	17
421357	367	421640	358	421887	367	422395	359	530121	17
421358	358	421641	358	421888	358	422431	364	530122	17
421362	357	421642	379	421889	358	422432	362	530125	17
421367	377	421643	366	421891	359	422436	379	530130	17
421369	369	421646	372	421892	356	422437	379	530131	17
421383	357	421647	369	421893	356	422438	379	530132	17
421384	362	421648	376	421898	378	429998	354	530135	17
421387	375	421655	360	421899	378	429999	354	530140	17
421393	362	421656	358	421901	364	43		530141	17
421397	369	421664	358	421903	371	430000	381	530142	17
421406	360	421665	378	421904	371	430001	381	530145	17
421411	365	421666	365	421905	373	430007	381	530150	17
421417	355	421667	378	421906	373	430008	381	530151	17
421419	371	421669	361	421907	359	45		530155	17
421421	377	421673	369	421908	373	450500	347	530160	17
421423	366	421674	366	421909	377	450510	347	530161	17
421428	366	421676	369	421910	359	450520	347	530200	18, 115
421431	377	421685	379	421911	373	450900	380	530201	18, 115
421439	360	421726	355	421912	373	451000	381	530202	18, 115
421443	366	421727	365	421915	373	53		530203	18, 115
421456	367	421739	358	421916	373	530000	16	530204	18
421457	365	421744	356	421917	361	530001	16	530205	18
421479	371	421745	378	421919	364	530002	16	530206	19
421480	380	421746	365	421920	373	530003	16	530207	19
421483	363	421753	372	421921	373	530005	16	530210	18
421493	366	421754	372	421922	373	530010	16	530211	18
421495	376	421760	369	421923	374	530011	16	530212	18
421498	363	421764	372	421924	374	530012	16	530213	18
421513	355	421769	379	421929	374	530013	16	530214	18

DE	ARTIKELNUMMERN-INDEX
GB	ITEM NUMBER INDEX
IT	INDICE DEI CODICI DELL'ARTICOLO
ES	INDICE DE CÓDIGOS DE PRODUCTO

Art.-Nr. / code	S. / p.	Art.-Nr. / code	S. / p.	Art.-Nr. / code	S. / p.	Art.-Nr. / code	S. / p.	Art.-Nr. / code	S. / p.
530215	18	530471	20	820037	390	821083	391	902028	137
530216	19	530480	20	820041	390	821154	391	902032	137
530217	19	530481	20	820049	391	821165	391	904024	137
530220	18	530490	19	820060	390	821459	391	904026	137
530221	18	530491	19	820086	390	83		904028	137
530222	18	531000	22	820092	391	830001	392	904030	137
530223	18	531001	22	820097	391	830003	392	904032	137
530224	18	531002	22	820111	390	830006	392	904034	137
530225	18	531003	22	820116	390	830007	392	904036	137
530226	19	531004	22	820119	391	830008	392	904524	137
530227	19	531005	22	820120	391	830011	393	904526	137
530230	18	531006	22	820121	390	830012	392	904528	137
530231	18	531010	22	820122	390	830017	392	91	
530232	18	531011	22	820125	390	830018	392	910020	138
530233	18	531012	22	820127	391	830019	392	910025	138
530234	18	531013	22	820132	390	830020	392	910030	138
530235	18	531014	22	820134	390	830021	392	910035	138
530236	19	531015	22	820135	391	830024	392	912030	145
530237	19	531020	22	820136	391	830025	392	912035	145
530240	18	531021	22	820138	390	830027	392	915120	135
530241	18	531022	22	820141	390	830033	392	915122	135
530242	18	531023	22	820145	391	830039	392	915124	135
530243	18	531024	22	820153	391	830040	392	915126	135
530244	18	531030	22	820154	391	830047	392	915128	135
530245	18	531031	22	820181	390	830048	392	92	
530246	19	531032	22	820187	391	830050	392	920000	138
530247	19	531040	23	820191	390	830056	393	926820	135
530250	18	531041	23	820215	391	830057	393	926822	135
530251	18	531042	23	820227	391	830063	392	926824	135
530252	18	531050	23	820239	391	830090	393	926826	135
530253	18	531051	23	820241	390	830091	393	926828	135
530256	19	531052	23	820242	391	830092	393	93	
530257	19	531060	23	820248	391	830119	392	930020	135
530260	18	531061	23	820250	391	830120	392	931524	138
530261	18	531062	23	820268	390	88		931526	138
530266	19	531063	23	820286	390	880001	393	94	
530267	19	531064	23	820298	390	880002	393	940025	138
530270	18	531065	23	820302	392	880003	393	940027	138
530271	18	531066	23	820306	391	880005	393	949908	137
530272	18	531070	23	820319	392	880006	393	949910	137
530300	19	531071	23	820320	392	880007	393	949912	137
530301	19	531072	23	820321	392	880008	393	949928	137
530302	19	531073	23	820335	391	880015	393	949930	137
530310	19	531076	23	820404	390	880019	393	949932	137
530311	19	531077	23	820407	390	880026	393	95	
530312	19	531078	23	820408	391	880052	393	951012	139
530320	19	71		820409	391	880053	393	951014	139
530321	19	710000	388	820410	390	880115	393	951016	139
530322	19	711000	388	820411	390	880174	393	96	
530400	20	711111	388	820413	390	880258	393	960010	142
530401	20	81		820414	390	90		960020	142
530410	20	810021	392	820415	391	900020	136	960030	142
530411	20	810070	392	820416	391	900024	136	965000	140
530420	20	810173	392	820419	390	900026	136	965010	140
530421	20	810174	392	820420	390	900028	136	965020	140
530430	20	82		820421	390	900126	136	967028	136
530431	20	820001	390	820422	390	900128	136	967030	140
530440	20	820008	391	820423	390	901314	135	967040	140
530441	20	820009	391	820432	390	901316	135	967050	143
530450	20	820020	390	820601	388	901318	135	967060	143
530451	20	820031	390	820606	391	901320	135	967065	142
530460	20	820032	390	820931	392	901322	135	967070	142
530461	20	820033	390	820943	391	901324	135	967075	143
530470	20	820035	390	820991	391	901326	135	967080	143

DE	ARTIKELNUMMERN-INDEX
GB	ITEM NUMBER INDEX
IT	INDICE DEI CODICI DELL'ARTICOLO
ES	INDICE DE CÓDIGOS DE PRODUCTO

Art.-Nr. / code	S. / p.	Art.-Nr. / code	S. / p.	Art.-Nr. / code	S. / p.	Art.-Nr. / code	S. / p.
968000	141	995102	146	997260	80	997984	147
968010	141	995103	146	997280	80	997985	147
968020	141	995104	146	997300	80	997986	147
968030	141	995105	146	997320	80	997987	147
968040	141	995106	146	997360	80	997988	147
968050	141	995107	150	997400	80	997989	147
97		995121	148	997450	80	998020	151
977705	139	995122	148	997500	80	998021	151
977708	139	995123	148	997620	81		
977710	139	995124	148	997621	81		
977715	139	995125	148	997622	81		
977720	139	995126	148	997623	81		
98		995127	148	997624	81		
980020	145	995128	148	997625	81		
980024	145	995129	148	997630	80		
980026	145	995130	148	997631	80		
980028	145	995131	148	997632	80		
981026	145	995132	148	997633	80		
981028	145	995810	124	997634	80		
981040	145	995811	124	997635	80		
981041	145	995820	124	997636	80		
981050	145	995821	124	997637	80		
99		995830	124	997638	80		
994628	139	995840	124	997639	80		
994633	139	995841	124	997640	80		
994860	124	995860	124	997810	124		
995010	150	995870	125	997811	124		
995020	148	995880	125	997820	124		
995030	149	995890	125	997821	124		
995031	149	996020	148	997840	124		
995032	149	996030	149	997841	124		
995033	149	996031	149	997899	125		
995034	149	996032	149	997900	80		
995035	149	996033	149	997901	80		
995040	149	996034	149	997902	80		
995042	149	996035	149	997903	80		
995043	149	996040	149	997910	151		
995044	149	996042	149	997911	151		
995045	149	996043	149	997912	151		
995050	150	996044	149	997913	151		
995060	150	996045	149	997914	151		
995061	150	996070	151	997920	151		
995062	150	996071	151	997921	151		
995063	150	996072	151	997940	147		
995064	150	996110	151	997941	147		
995065	150	996111	151	997942	147		
995066	150	996121	148	997943	147		
995070	151	996122	148	997944	147		
995071	151	996123	148	997950	50		
995072	151	996124	148	997951	50		
995080	146	996125	148	997952	50		
995081	146	996126	148	997953	50		
995082	146	996127	148	997965	147		
995083	146	996128	148	997966	147		
995084	146	996129	148	997967	147		
995085	146	996130	148	997970	147		
995086	146	996131	148	997971	147		
995087	146	996132	148	997972	147		
995090	146	997140	80	997975	147		
995091	146	997160	80	997976	147		
995092	146	997180	80	997977	147		
995093	146	997200	80	997981	147		
995100	146	997220	80	997982	147		
995101	146	997240	80	997983	147		

Länge / length

Millimeter / millimeters (mm)	Zentimeter / centimeters (cm)	Inches (ins)
3	0,3	1/8
6,25	0,62	1/4
12,5	1,25	1/2
25	2,5	1
50	5	2
75	7,5	3
100	10	4
150	15	6
200	20	8
250	25	10
300	30	12
350	35	14
400	40	16
450	45	18
500	50	20
550	55	22
600	60	24
650	65	26
700	70	28
750	75	30
800	80	32
850	85	34
900	90	36
950	95	38
1000	100	40

Gewicht / Weight

Gramm / metric grams (g)	Kilogram / kilogram (kg)	Masse / imperial ounces (oz)	/ imperial pounds (lb)
25	0,25	1	
50	0,5	2	
75	0,75	3	
100	0,1	4	1/4
125	0,125	-5	
150	0,15	+5	
175	0,175	6	
200	0,2	7	
225	0,225	8	1/2
250	0,25	9	
275	0,275	10	
300	0,3	11	
325	0,325	12	3/4
350	0,35	+12	
375	0,375	13	
400	0,4	14	
425	0,425	15	
450	0,45	16	1
675	0,675	22	1,5
1000	1,0	35	2,2
1500	1,5	53	3,3
2000	2,0	71	4,4
2500	2,5	88	5,5
3000	3,0	106	6,6
3500	3,5	123	7,7

Volume

Metrik / Metric (ml/l)	Unzen / Imperial Fluid Ounces (fnoz)	Imperial Pints	Unzen / US Fluid Ounces	US Pints
30 ml	1		1.01	
60 ml	2		2.02	
90 ml	3		3.04	
120 ml	4		4.05	1/4 US pt
150 ml	5	1/4 pt	5.07	
180 ml	6		6.09	
210 ml	7		7.1	
240 ml	8		8.12	1/2 US pt
270 ml	9		9.13	
300 ml	10	1/2 pt	10.14	
330 ml	11		11.16	
360 ml	12		12.17	3/4 US pt
390 ml	13		13.2	
420 ml	14		14.2	
450 ml	15	3/4 pt	15.21	
480 ml	16		16.23	1 US pt
600 ml	20	1 pt	20.28	
960 ml	32		32.46	2 US pt
1 L	35		33.81	2.1 US pt
1.1 L	40	2 pt	37.17	2.32 US pt
5 L	176	8.8 pt	169.07	10.56 US pt
6 L	211	10.56 pt	202.88	12.68 US pt
7 L	246	12.31 pt	236.7	14.75 US pt
8 L	282	14.1 pt	270.51	16.8 US pt
10 L	352	17.6 pt	338.14	21.1 US pt

Temperatur / temperature

°C	°F
-40	-40
-30	-22
-20	-4
-10	14
0	32
10	50
20	68
30	86
40	104
50	122
60	140
70	158
80	176
90	194
100	212
110	230
120	248
130	266
140	284
150	302
160	320
170	338
180	356
190	374
200	392

Gebrauchshinweise

Wir empfehlen generell, alle Produkte, sofern nicht anders beschrieben, nicht mit aggressiven Reinigungsmittel zu reinigen. Um die Lebensdauer zu verlängern und die Qualität des Produktes zu erhalten, ist das Reinigen mit herkömmlichen Spülmitteln empfohlen. Der Einsatz von Industriespülmaschinen unter Verwendung teils aggressiven Reinigern kann Kunststoffe porös machen, Beschichtungen angreifen und das Produkt verfärben.

Weitere Informationen sowie unsere Allgemeine Geschäftsbedingungen finden Sie unter www.schneider-gmbh.com

Instructions for use

We generally recommend not to clean all products with aggressive cleaning agents, unless otherwise described. In order to extend the service life and maintain the quality of the product, cleaning with conventional detergents is recommended. The use of industrial dishwashers with partly aggressive cleaners can make plastics porous, attack coatings and discolour the product.

Further information and our General Terms and Conditions can be found at www.schneider-gmbh.com



© COPYRIGHT

d Wir übernehmen keine Haftung für Irrtümer und Druckfehler. Konstruktions- und Ausstattungsänderungen vorbehalten. Die Vervielfältigung dieses Katalogs auch wenn partial – ohne unsere ausdrückliche schriftliche Erlaubnis ist untersagt. Fotos und Abmessungen sind nur als information zu verstehen. Wir behalten uns das Recht vor, die angegebenen Spezifikationen jederzeit zu ändern, sofern es aus produktionstechnischen Gründen erforderlich ist.

it Non ci assumiamo alcuna responsabilità per errori ed imprecisioni di stampa. Le misure e caratteristiche dei prodotti sono soggette a variazioni senza obbligo di preavviso. Ogni riproduzione anche parziale del presente catalogo è vietata se non espressamente autorizzata per iscritto da Schneider GmbH. Le misure, caratteristiche ed illustrazioni dei prodotti sono indicative e soggette a variazioni senza preavviso qualora esigenze tecnico produttive lo richiedessero.

gb We are not responsible for mistakes and misprints. Changes in design and equipment are possible. This catalogue may not be reproduced in whole or in part unless specific prior written authorization of Schneider GmbH. The pictures illustrated and data are representatives. We reserve the right to alter at any time the specifications stated without notice, whenever technical requirements shall so demand.

es No aceptamos ninguna responsabilidad por errores y erratas. Las medidas y especificaciones de los productos son susceptibles de modificación sin previo aviso. Queda prohibida la reproducción total o parcial de este catálogo sin autorización de forma expresa y por escrito de Schneider GmbH. Fotos, datos y medidas que aparecen en este catálogo son indicativos y susceptibles, sin previo aviso, de modificación por exigencias técnicas o de producción.

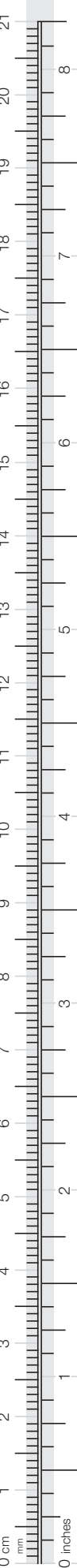

Schneider GmbH

In der Längerts 1
D-73095 Albershausen

Phone: +49 (0) 71 61 / 3004 -0
Fax: +49 (0) 71 61 / 3004 -50
Email: info@schneider-gmbh.com

www.schneider-gmbh.com



4 028574 309998

099000