





QUALITÄT AUS LEIDENSCHAFT

Equipment for professionals – unsere Philosophie

Ein umfangreiches Sortiment an Fachgeräten und Zubehör bieten wir unseren Kunden weltweit. Unsere qualitativ hochwertigen Produkte finden Ihren Einsatz in der Bäckerei, Konditorei, Hotel- und Gastronomie, Kantinen und in der Lebensmittelindustrie.

Über 3000 Artikel sind fast permanent verfügbar und können je nach Kundenwunsch individuell bedruckt oder verpackt werden. Kundenservice wird bei uns groß geschrieben. Kurze Lieferzeiten, einfaches und schnelles Handling sowie eine enorm hohe Lagerverfügbarkeit ist für uns Service – und davon profitieren unsere Kunden.

PASSION FOR QUALITY

Equipment for professionals – our philosophy

We offer a wide range of professional equipment and utensils to our clients all over the world.

Our top quality products are conceived for professional use in bakeries, pastry shops, hotels, restaurants, cafeterias, canteens, in the catering business, and in the food industry in general.

More than 3000 items are almost permanently available and can be customised by printing and packaging according to the customer's specifications. To serve our customers is our first priority. Good service includes for us short delivery periods, simple and fast handling and an extremely vast stock availability – and our customers benefit from this.

LA PASSIONE PER LA QUALITÀ

Attrezzature per i professionisti – la nostra filosofia

Una linea completa di attrezzature e utensili professionali per i nostri clienti di tutto il mondo.

I nostri migliori prodotti sono studiati per un utilizzo professionale nelle pasticcerie, forni, hotels, ristoranti, bar, mense, nel catering e nell'industria alimentare in generale.

Più di 3000 prodotti disponibili a catalogo con la possibilità di essere personalizzati con loghi e confezioni su richiesta specifica del cliente.

La nostra priorità è servire il cliente. Fornire un buon servizio per noi significa accorciare i tempi di spedizione, avere una gestione semplice e rapida con una vasta disponibilità di prodotti – con beneficio del cliente.

LA PASIÓN POR LA CALIDAD

Equipamiento para profesionales – nuestra filosofía

Nosotros ofrecemos una amplia gama de ofertas de equipos especiales y accesorios por nuestros clientes en todo el mundo.

Nuestros productos de alta calidad encuentran su uso en la panadería, en el hotel y restaurantes, cantinas y en la industria alimentaria.

Más de 3000 artículos son casi permanentemente disponible y pueden ser impreso individualmente o empaquetados de acuerdo con el cliente. El servicio del cliente es muy importante para nosotros. Entrega corto veces, la manipulación rápida y simple, así como una disponibilidad del almacén extremadamente alto es el servicio – y el beneficio de nuestros clientes.



Maschinen & Geräte | machines & appliances | macchine | maquinas 8 – 15

Backen | baking | cottura | cocer 16 – 27

Fachgeräte | utensils | attrezzatura | utensilios 28 – 61

Präsentieren | presentation & display | presentare | presentar 62 – 65

Transportieren & Lagern | Transportation & storage |
trasporto e stoccaggio | transporte y almacenamiento 66 / 67



400 Seiten, über 3000 Artikel



SCHNEIDER

equipment for professionals



Gut präsentiert und gut sortiert – so verkauft es sich am besten!
Great presentation, Great assortment – Great Sales!

SB-DISPLAYS
SB-DISPLAYS

Artikel-Nr. Code	Beschreibung	Description	Größe Size	EAN
460001	Spritzbeutel	Pastry bag	1-28 cm	4028574266826
460002	Spritzbeutel	Pastry bag	2-34 cm	4028574266833
460003	Spritzbeutel	Pastry bag	3-40 cm	4028574266840
460004	Spritzbeutel	Pastry bag	4-46 cm	4028574266857
460005	Spritzbeutel	Pastry bag	5-50 cm	4028574266864
460006	Spritzbeutel-Garnitur 9-tig.	Pastry bag set 9-pcs.	31 cm	4028574266871
391200	Einwegspritzbeutel	Disposable pastry bag	35 cm	4028574030373
391210	Einwegspritzbeutel	Disposable pastry bag	47 cm	4028574030380
391220	Einwegspritzbeutel	Disposable pastry bag	53 cm	4028574030397
460007	Tüllen-Set Kunststoff, Stern	Star tube set, plastic	3, 5, 7, 9, 11, 13 mm	4028574266888
460008	Tüllen-Set Kunststoff, Loch	Plain tube set, plastic	3, 5, 7, 9, 11, 13 mm	4028574266895
460009	Tüllen-Set Edelstahl, Stern	Star tube set, stainless steel	4, 6, 8, 10, 13, 15 mm	4028574266901
460010	Tüllen-Set Edelstahl, Loch	Plain tube set, stainless steel	4, 6, 8, 10, 13, 15 mm	4028574266918
460011	Stipprolle	Roller docker	12 cm	4028574266925
460012	Gitterschneider	Lattice Cutting Roller	12 cm	4028574266932
460013	Teigschneider	Expandable Dough Cutter	5 x glatt / 5 x plain	4028574266949
460014	Teigschneider	Dough Cutter	Ø 5,5 cm glatt / plain	4028574266956
460015	Stielschaber	Spatula	27 cm	4028574266963
460016	Stielschaber	Spatula	33 cm	4028574266970
460017	Stielschaber Silikon	Spatula silicone	28,5 cm	4028574266987
460018	Stielschaber Silikon	Spatula silicone	32,5 cm	4028574266994
460019	Rührspatel	Spatula	25 cm	4028574267007
460020	Rührspatel	Spatula	30 cm	4028574267014
460021	Rührspatel	Spatula	35 cm	4028574267021
460022	Rührspatel	Spatula	40 cm	4028574267038
460023	Rührspatel	Spatula	45 cm	4028574267045
460024	Rührspatel	Spatula	50 cm	4028574267052
460025	Spachtel Edelstahl	Spatula stainless steel	6 cm	4028574267069
460026	Spachtel Edelstahl	Spatula stainless steel	8 cm	4028574267076
460027	Spachtel Edelstahl	Spatula stainless steel	10 cm	4028574267083
460028	Spachtel Edelstahl	Spatula stainless steel	12 cm	4028574267090
460029	Spachtel Edelstahl	Spatula stainless steel	11 x 12 cm	4028574267106
460030	Spachtel Edelstahl	Spatula stainless steel	12 x 12 cm	4028574267113
460031	Spachtel Edelstahl	Spatula stainless steel	13,5 x 13,5 cm	4028574267120
460032	Spachtel Trapez	Spatula Trapez	17 cm	4028574267137
460033	Pinsel Silikon	Brush silicone	5 cm	4028574267144
460034	Pinsel	Brush	4 cm	4028574267151
460035	Pinsel	Brush	5 cm	4028574267168
460036	Pinsel	Brush	6 cm	4028574267175
460037	Pinsel	Brush	7,5 cm	4028574267182
460038	Pinsel Holzgriff, 2-er Set	Brush wood, set á 2	3 + 4 cm	4028574267199
460039	Backmatte	Baking mat	31,5 x 52 cm (GN1/1)	4028574267205
460040	Backmatte	Baking mat	38,5 x 58,5 cm	4028574267212
227027	Tortenplatte Melamin weiß	Cake plate melamine white	Ø 32 cm	4028574006439
227015	Tablett Melamin, schwarz	Display tray melamine black	42 x 28 cm	4028574006699
227094	Tablett Melamin, schwarz	Display tray melamine black	58 x 19,5 cm	4028574021166
227096	Tablett Melamin, schwarz	Display tray melamine black	60 x 40 cm	4028574021180
200900	Backlineal	Ruler	64 cm	4028574229005
153090	Gasbrenner	Torch	16,5 cm	4028574252850
206011	Meßbecher, stapelbar	Measuring cup, stackable	0,5 ltr.	4028574261869
206012	Meßbecher, stapelbar	Measuring cup, stackable	1,0 ltr.	4028574261876
206013	Meßbecher, stapelbar	Measuring cup, stackable	2,0 ltr.	4028574261883
206014	Meßbecher, stapelbar	Measuring cup, stackable	3,0 ltr.	4028574261890
206015	Meßbecher, stapelbar	Measuring cup, stackable	5,0 ltr.	4028574261906
460041	Deckel für Meßbecher	Lid for measuring cup	1,0 ltr.	4028574267229
460042	Deckel für Meßbecher	Lid for measuring cup	2,0 ltr.	4028574267236
460043	Tortenteiler	Tart marker	8/12-teilig	4028574267243
460044	Tortenteiler	Tart marker	12/16-teilig	4028574267250
460045	Tortenteiler	Tart marker	14/16-teilig	4028574267267
460046	Tortenscheibe Alu	Cake disc, alu	Ø 28 cm, 1,0 mm	4028574267274
290000	Rührschüssel PP	Mixing bowl PP	1,0 ltr.	4028574034234
290010	Rührschüssel PP	Mixing bowl PP	2,5 ltr.	4028574034241
290020	Rührschüssel PP	Mixing bowl PP	4,5 ltr.	4028574034258
290030	Rührschüssel PP	Mixing bowl PP	6,0 ltr.	4028574034265
290040	Rührschüssel PP	Mixing bowl PP	9,0 ltr.	4028574034272
290050	Rührschüssel PP	Mixing bowl PP	13,0 ltr.	4028574034289
200022	Seiher	Strainer	36 cm	4028574010702
230100	Vorratsdose	Container	2,0 ltr.	4028574034296
230110	Vorratsdose	Container	3,0 ltr.	4028574034302
460047	Schaufel-Set	Set of Scoops	18 cm, 25 cm, 31 cm	4028574267281
460048	Backhandschuh	Baking mitten	34 cm	4028574267298
460049	Tortenspitzen rund	Doilies round	Ø 10 cm	4028574267304
460050	Tortenspitzen rund	Doilies round	Ø 12 cm	4028574267311
460051	Brötchen-Messer- 2er Set	Roll knives-set á 2	18cm	4028574267328
260031	Palette, stumpf	Spatula, blunt	21 cm	4028574016445
260032	Palette, stumpf	Spatula, blunt	26 cm	4028574016452
260041	Winkelpalette, stumpf	Spatula, angular	21 cm	4028574016490
260042	Winkelpalette, stumpf	Spatula, angular	26 cm	4028574016506
260570	Brotmesser, Schneide	Breadknife, plain	31 cm	4028574016735
260571	Brotmesser, Welle	Breadknife, wave	31 cm	4028574016742
260610	Tortenmesser, Schneide/Säge	Pie knives plain/saw	16 cm	4028574016827
260612	Tortenmesser, Säge, Welle	Pie Knives saw/wave	16 cm	4028574016841
260640	Konditormesser, Schneide	Confectioners's Knives, plain	36 cm	4028574016919
260642	Konditormesser, Welle	Confectioners's Knives, wave	36 cm	4028574016933
260710	Backblechmesser	Baking tray knives	25 cm	4028574017084
152901	Dosierspender, rund	Dispenser, round	350 ml	4028574016315
152902	Dosierspender, rund	Dispenser, round	950 ml	4028574016322
152911	Dosierspender, eckig	Dispenser, square	750 ml	4028574016353
152912	Dosierspender, eckig	Dispenser, square	1250 ml	4028574016360
460052	Teigschaber-Set	Dough scraper set	4-teilig / 4 pcs.	4028574267335
199920	Likör- und Fondanttrichter	Confectionery Funnel	1,9 ltr.	4028574021272
200163	Wellholz	Rolling pin	40 cm	4028574009089
115011	Silikonform MUFFIN	Silicone mold MUFFIN	6 x Ø 6,9 cm	4028574034494
115012	Silikonform MUFFIN	Silicone mold MUFFIN	11 x Ø 5,1 cm	4028574034500
115036	Silikonform BISKUIT	Silicone mold BISCUIT	3 x Ø 10,3 cm	4028574034593
115071	Silikonform GUGELHUPF	Silicone mold GUGELHOPF	6 x Ø 7 cm	4028574034647
115308	Silikonform MUFFIN (40x60)	Silicone mold MUFFIN	24 x Ø 7 cm	4028574252515
115310	Silikonform GUGELHUPF (40x60)	Silicone mold GUGELHOPF	35 x Ø 7,3 cm	4028574252539





d	CREPES-EISEN
gb	CREPE MAKER
it	CREPIERA TONDA
es	MÁQUINA PARA CREPES

eine Platte 40 cm Durchmesser, Teflon-Beschichtung, Aussengehäuse Edelstahl, Temperatur stufenlos regelbar (50°C – 300°C), geringer Energieverbrauch, inklusive Schublade und Holzverteiler, Leistung 3 kW, 230 Volt

one plate 40 cm diameter, teflon-coated, body housing made of stainless steel, temperature continuously adjustable (50°C – 300°C), low energie consumption, including drawer and wooden stick, power 3 kW, 230 V

Art.-Nr./code	L / B / H (mm)	Gewicht / weight (kg)	VE/unit
157100	500 x 450 x 220	23	1

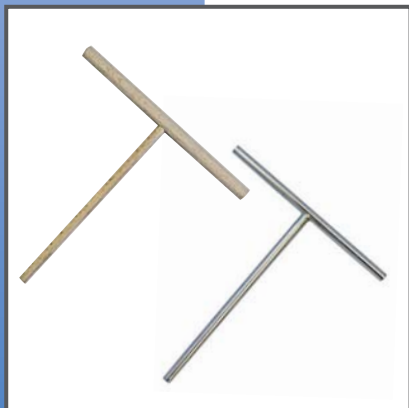

d	CREPES-SCHIEBER
gb	CREPE SLIDER
it	STENDI PASTELLA PER CREPIERA
es	CORREDERA

Art.-Nr./code	Abmessungen / size (mm)	Material/made of	VE/unit
157760	180 x 185	Holz/wood	1
157770	230 x 200	Edelstahl/stainless	1



d	CREPES-WENDER
gb	CREPE SPATULA
it	SPATOLA PER CREPE
es	ESPÁTULA CREPE

Material: Holz *made of wood*

Art.-Nr./code	Abmessungen / size (mm)	VE/unit
157780	430 x 35	1

WAFFEL-EISEN „QUADRO“
WAFFLE MAKER
MACCHINA PER CIALDE
GOFRERA

d
gb
it
es



Festmontierte Backplatte. fixed plate, for 2 waffles:
Für zwei Waffeln: size: 8 x 16 x 1,5 cm
Größe: 8 x 16 x 1,5 cm

Art.-Nr./code	L / B / H (mm)	Gewicht / weight (kg)	VE/unit
157200	300 x 320 x 300	24	1

WAFFEL-EISEN „BELGIEN“
WAFFLE MAKER
MACCHINA PER CIALDE
GOFRERA

d
gb
it
es



Wechselbare Backplatte. removable plate, for 2 waffles:
Für zwei Waffeln: size: 4,9 x 20,5 x 2,6 cm
Größe: 4,9 x 20,5 x 2,6 cm

Art.-Nr./code	L / B / H (mm)	Gewicht / weight (kg)	VE/unit
157400	300 x 320 x 300	31	1



WECHSELPLATTEN / ZUBEHÖR
WAFFLE IRONS / ACCESSORIES
PIASTRA DI CIALDE / ACCESSORI
PLACA PARA GOFRE / ACCESORIOS



edhard

GASTRO-SET



d	DOSIERMASCHINE "EDHARD"
gb	DOSINGMETER "EDHARD"
it	DOSATRICE "EDHARD"
es	INYEKTORA-DOSIFICADORA "EDHARD"

Edhard Dosiermaschine: zum automatischen Befüllen, Dosieren und Dekorieren von Lebensmittel aller Art wie z. B. Frischkäse, Sahen, Cremes, Glasuren, Gelee, Ketchup, Sirup, Senf, Pudding, Püree, Salat-Dressing, Joghurt und viele andere Produkte.

Automatic dosingmeter for injecting, depositing, layering and topping. A partial list of food products using the dosing systems: Cottage cheese, cream cheese, creams, custard, icing, jelly, ketchup, molasses, mustard, pudding, purees, salad dressing, yogurt and many other products.





edhard GASTRO-SET

Das Edhard-System beinhaltet
3 Hauptkomponenten: Motorblock,
Trichter und Pumpeneinheit (Dosiertülle).

*This equipment consists of three
main components: Power base, filler unit
(pump and hopper) and the spouts.*

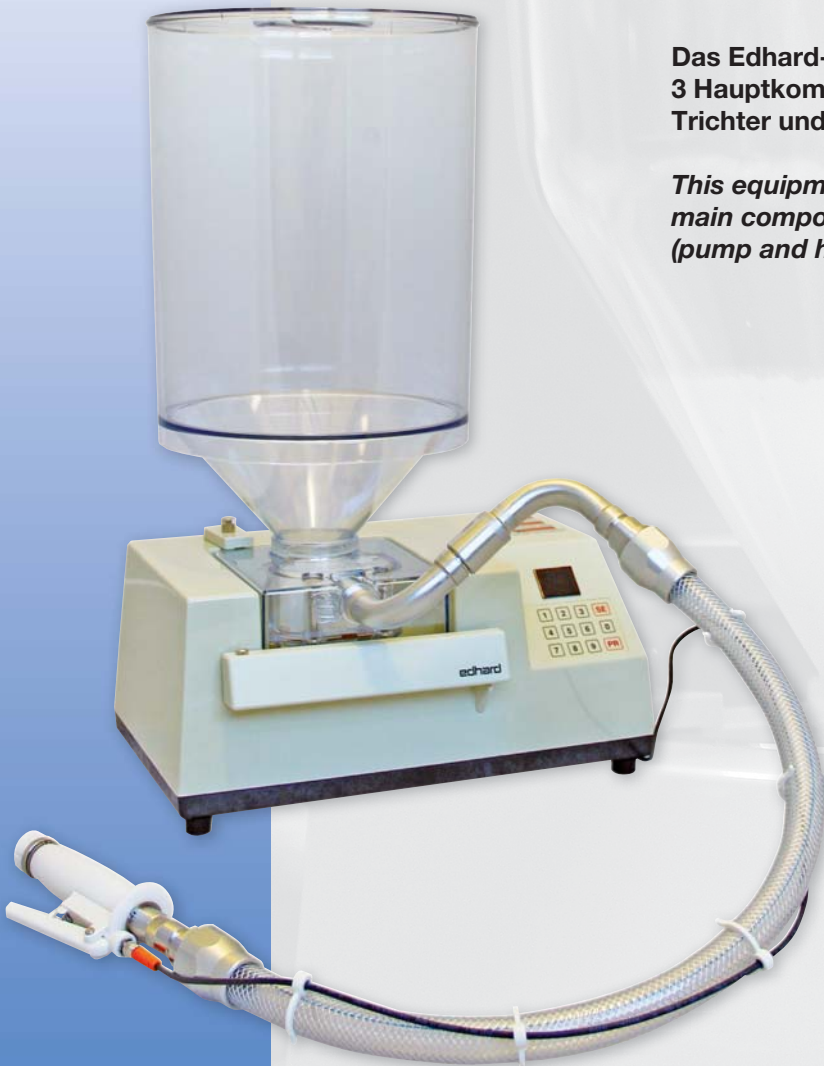

151600 **44**



44 W

152861 (17,0 l) **93**



152860 (5,5 l) **186**

152850 **93**



186

151605 **93**



93 W

152862 (17,0 l) **93**



186

152851 **93**



186

152609 **186**



186 W

151612 (17,0 l) **44**



151610 (5,5 l) **93**

186

152677



151620 **186**
Edelstahl / stainless steel



186 W

151613 (17,0 l) **44**



151611 (5,5 l) **93**

186

152665





d LIKÖR- UND FONDANTTRICHTER
gb CONFECTIONERY FUNNEL
it IMBUTI COLATORI
es EMBUDOS COLADORES

Material: Edelstahl
 ergonomischer Griff aus Kunststoff, mit
 3 Dosiertüllen (2, 4 und 6 mm), inklusive
 Ständer und Auffangschale

*made of stainless steel,
 ergonomic handle made of plastic,
 with three different nozzles (2, 4 und
 6 mm), wire rack and dripping dish*

Art.-Nr./code	ø (mm)	Höhe/height (mm)	Volumen/vol. (l)	VE/unit
199920	190	220	1,9	1



d KAREMELLISIERER / GASBRENNER
gb SUGAR / BLOWTORCH / CAMELIZER
it CANNELLO
es FLAMBEADOR

für Crème Brulée, Karamellisieren von
 Speisen aller Art etc.
 einfaches und schnelles Befüllen mit Feuer-
 zeuggas, Gehäuse aus Stahl, Fuß aus
 Kunststoff, einfach zu bedienen, mit Kinder-
 sicherung, verschleißfreie Piezo-Zündung,
 Flamme einstellbar, Flamme bis ca. 1450 °C

*for Crème Brulée, caramelizing all kinds
 of food
 easy and quick refill with lighter gas, body
 made of steel, easy to use, child proof
 safety lock system, self-igniting Piezo
 Ignition, safety adjustable flame, flame
 up to 1450 °C*

Art.-Nr./code	Höhe/height (mm)	ø (mm)	VE/unit
153090	165	45	1



SPRÜHPISTOLE "ALEXO 200"	d
SPRAY GUN "ALEXO 200"	gb
PISTOLA POLVERIZZATRICE ELETTRICA "ALEXO 200"	it
PISTOLA PULVERIZADORA ELÉCTRICA "ALEXO 200"	es

verarbeitbare Materialien:

Butter, Öle, Fette, Wachse, Gelee, Konfitüre, Schokolade, Trennmittel und Emulsionen absolut lebensmitteltauglich, für warme Flüssigkeiten bis 65 °C
Fördermenge: 280 g/min
Inhalt: 700 ml

usability:

butter, oil, fat, wax, jelly, jam, chocolate, releasing agent and emulsion – for food-stuffs, usable for liquids max. 65 °C
conveyor quantity: 280 g/min
volume: 700 ml

wird mit Rundstrahldüse R4 geliefert

supplied with ray nozzle R4



Art.-Nr./code	Beschreibung/description (mm)	VE/unit
153900	Sprühpistole/spray gun	1

SPRÜHPISTOLE "ALEXO 400"	d
SPRAY GUN "ALEXO 400"	gb
PISTOLA POLVERIZZATRICE ELETTRICA "ALEXO 400"	it
PISTOLA PULVERIZADORA ELÉCTRICA "ALEXO 400"	es

verarbeitbare Materialien:

Butter, Öle, Fette, Wachse, Gelee, Konfitüre, Schokolade, Trennmittel und Emulsionen **absolut lebensmitteltauglich**, für warme Flüssigkeiten bis 65 °C
Fördermenge: 280 g/min
Inhalt: 700 ml

usability:

butter, oil, fat, wax, jelly, jam, chocolate, releasing agent and emulsion – for food-stuffs, usable for liquids max. 65 °C, the removeable parts are dishwasher safe conveyor quantity: 280 g/min
volume: 700 ml

wird mit Rundstrahldüse R4 geliefert

supplied with ray nozzle R4



Art.-Nr./code	Durchmesser /diameter	VE/unit
153960	700 / 1400 mm	1





d	RÜHR- UND KNETMASCHINE "CHEF 5000"
gb	MIXING AND KNEADING MACHINE "CHEF 5000"
it	IMPASTATRICE ELETTRONICA "CHEF 5000"
es	BATIDORA MEZCLADORA "CHEF 5000"

- hohe Stabilität durch Metallfuß
- leistungsfähiger Motor (40 bis 240 Umdrehungen pro Minute)
- Edelstahl-Schüssel für 5 Liter Volumen
- abnehmbare Schutzhaube aktiviert das Anheben und Absenken der Schüssel
- inklusive Schaber, Knethaken, Rührbesen und Schneebesens
- *robust construction with heavy foot made of metal*
- *powerful motor (beater speeds from 40 to 340 rpm)*
- *stainless steel bowl with 5 litres capacity safety screen is linked with the bowl*
- *including scraper, kneading hook, beater for mixing and whisk*

Art.-Nr./code	Leistung/power	Spannung/volt.	Abm./dim. (mm)	VE/unit
153800	500 W	240 V	284 x 382 x 434	1



d	STABMIXER "S-MIX 1"
gb	HAND BLENDER "S-MIX 1"
it	FRULLATORE "S-MIX 1"
es	BATIDOR TRITURADOR "S-MIX 1"

Stab, Fuß und Universalmesser aus Edelstahl, einfach zu reinigen; 2 Geschwindigkeiten wählbar, Verarbeitungsmenge: 20 l; Kabel 2 Meter, inklusive Wandhalterung 230 Volt, 50 Hz; Gewicht: 1,2 kg

Shaft, foot and blades in stainless steel, easy to clean, 2 speeds possible, processing quantity up to 20 ltr.; including 2 meters of cable and hanging loop; 230 volt, 50 Hz; weight: 1,2 kg

Art.-Nr./code	Drehzahl/number of rev.	Leistung/power	Länge Rührstab/stirrer length	Gesamtlänge/total length	VE/unit
150400	15.000 – 20.000	250 Watt	200 mm	380 mm	1



d	STABMIXER "S-MIX 2"
gb	HAND BLENDER "S-MIX 2"
it	FRULLATORE "S-MIX 2"
es	BATIDOR TRITURADOR "S-MIX 2"

Stab, Fuß und Universalmesser aus Edelstahl, einfach zu reinigen; 2 Geschwindigkeiten und Dauerbetrieb wählbar, Verarbeitungsmenge: 200 l; Kabel 4 Meter, inklusive Wandhalterung; 230 Volt, 50 Hz; Gewicht: 4,0 kg

Shaft, foot and blades in stainless steel, easy to clean, 2 speeds possible, processing quantity up to 200 ltr.; including 4 meters of cable and hanging loop; 230 volt, 50 Hz; weight: 4,0 kg

Art.-Nr./code	Drehzahl/number of rev.	Leistung/power	Länge Rührstab/stirrer length	Gesamtlänge/total length	VE/unit
150450	14.000 – 17.000	550 Watt	500 mm	760 mm	1

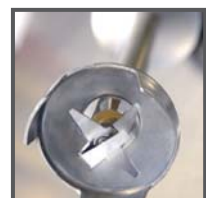

TOMATENSCHNEIDE-GERÄT	d
TOMATO SLICER	gb
AFFETTA POMODORI	it
CORTA TOMATES	es

Material: Edelstahl; Schnittbreite: 5,5 mm; *made of stainless steel; slices 5,5 mm;*
 spülmaschinengeeignet *dishwasher proof*

Art.-Nr./code	Länge/length	Breite/width	Höhe/height	Gew./weight	VE/unit
151055	300 mm	140 mm	180 mm	2,5 kg	1



INDUSTRIE-DOSENÖFFNER	d
INDUSTRIAL CAN OPENER	gb
APRISCATOLE INDUSTRIALE	it
ABRELATAS INDUSTRIAL	es

Material: vernickelter Stahl oder Edelstahl *made of nickel plated steel or stainless steel*

Art.-Nr./code	Länge/length (mm)	Gew./weight	VE/unit
151170	600 mm (vernickelt)	2,5 kg	1
151175	600 mm (Edelstahl)	2,5 kg	1
151171	Ersatz-Messer/knife		1
151172	Zahnrad/gear wheel		1



INFRAROT-THERMOMETER	d
INFRARED THERMOMETERS	gb
TERMOMETRO INFRAROSSO	it
TERMOMETRO INFRARROJO	es

für berührungsloses Messen der Oberflächentemperatur, mit Laservisier, einfach zu bedienen, beleuchtetes Display, Messdauer 1,0 Sekunden, inklusive Batterie und Tasche *for non-contact measuring of surface temperature, with laser-sighting, easy to use, backlight display, measuring time 1,0 seconds, battery and bag enclosed*

Art.-Nr./code	Messbereich/range	Abmessungen/sizes (mm)	VE/unit
160019	-33 bis +500 °C	175 x 39 x 79	1



THERMOMETER UND TIMER	d
THERMOMETER AND TIMER	gb
TERMOMETRO E OROLOGIO PROGRAMMABILE	it
TERMOMETRO Y TEMPORIZADOR	es

zur Temperaturmessung, inklusive Alarmfunktion, Edelstahlsonde mit 1 Meter hitzebeständigem Kabel, Speicherung der Höchst- und Tiefsttemperatur, mit Uhr, Timer und Stoppuhr, als Tischgerät verwendbar oder mit Befestigungsmagnet, inklusive Batterie

for temperature measurements during food preparation, alarm at present temperature, stainless steel probe with 1 m heat resistant cable, memory of highest and lowest temperature, with clock, timer and stopwatch, foldable display for table standing and magnet for fixing, battery included

Art.-Nr./code	Messbereich/range	VE/unit
160017	-10 bis +200 °C	1

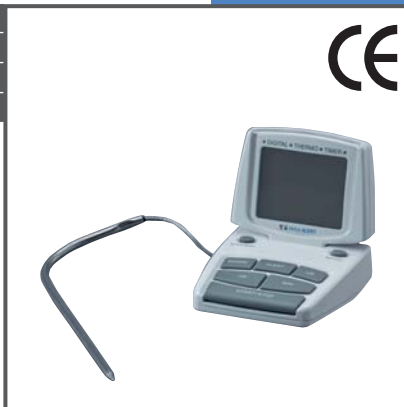



d	BACK- UND TIEFKÜHLMATTEN
gb	BAKING AND FREEZER MATS
it	TAPPETI DA FORNO E DA CONGELAZIONE
es	HOJAS PARA COCCIÓN Y REFRIGERACIÓN

Material silikonbeschichtetes Glasfibergewebe, sehr robust, temperaturbeständig von -40 °C bis +300 °C, vorzügliche Antihaltfähigkeit, vorteilhaft in Verbindung mit großlochigen Blechen

made of siliconized tissue, very strong quality, usable from -40 °C to +300 °C, excellent non-stick quality, profitable in combination with baking tins with large holes

Art.-Nr./code	Abmessungen/sizes (mm)	Bleche/baking tins (mm)	VE/unit
107785	315 x 520	325 x 530 (GN 1/1)	1

Sonderformate auf Anfrage / special sizes upon request

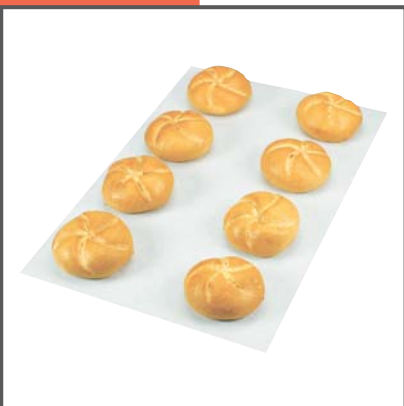

d	BACKTRENNPAPIERE "SUPER EXTRA"
gb	BAKING RELEASE PAPERS "SUPER EXTRA"
it	CARTA DA FORNO SILICONATA "SUPER EXTRA"
es	PAPEL DE HORNO SILICONADO "SUPER EXTRA"

aus Pergamentersatz, gebleicht, Flächengewicht 41 g/m² beidseitig silikonisiert, mehrmals verwendbar

greaseproof, bleached, grammage 41 g/m² two sides siliconized, multiple bakes

Art.-Nr./code	Abmessungen/dimensions		VE/unit
103100	400 mm x 600 mm		500
103032	320 mm x 530 mm	GN (1/1)	500

Sonderformate auf Anfrage / special sizes upon request

BACKBLECHE GN 1/1	d
BAKING TRAYS GN 1/1	gb
TEGLIE GN 1/1	it
PLACAS GN 1/1	es

Material: Aluminium (AlMn), ohne Lochung; *Made of aluminium, without perforation;*
 Materialstärke: 1,5 mm; *thickness: 1,5 mm;*
 Ausführung: 4 Seiten 45° *type: 4 sides 45°*

Art.-Nr./code	Länge/length	Breite/width	Höhe/height	VE/unit
381050	530 mm	325 mm	10 mm	10



BACKBLECHE / LOCHBLECHE GN 1/1	d
BAKING TRAYS / PERFORATED TRAYS GN 1/1	gb
TEGLIE FORATE GN 1/1	it
PLACAS PERFORADAS GN 1/1	es

Material: Aluminium (AlMn), Lochung 3 mm; *Made of aluminium, perforation 3 mm;*
 Materialstärke: 1,5 mm; *thickness: 1,5 mm;*
 Ausführung: 4 Seiten 45° *type: 4 sides 45°*

Art.-Nr./code	Länge/length	Breite/width	Höhe/height	VE/unit
381051	530 mm	325 mm	10 mm	10



BACKBLECHE / LOCHBLECHE GN	d
BAKING TRAYS / PERFORATED TRAYS GN	gb
TEGLIE FORATE GN	it
PLACAS PERFORADAS GN	es

Material: Aluminium (AlMn), Lochung 3 mm; *Made of aluminium, perforation 3 mm;*
 Antihafbeschichtung: Silikon, rot *Non-stick coating: silicone (red)*
 Materialstärke: 1,5 mm; *thickness: 1,5 mm;*
 Ausführung: 4 Seiten 45° *type: 4 sides 45°*

Art.-Nr./code	Länge/length	Breite/width	Höhe/height	VE/unit
381052	530 mm	325 mm	10 mm	10
381054	650 mm	530 mm	10 mm	10



BACK-TRENNSPRAY FÜR FORMEN UND BLECHE	d
RELEASE SPRAY FOR BAKING TINS AND TRAYS	gb
SPRAY ANTI ADERENTE	it
DESMOLDEANTE EN SPRAY	es

Kein Anbacken oder Ankleben der Backwaren. Reines Lebensmittel, 100 % geschmacksneutral.

**Nur zur gewerblichen Verarbeitung.
 Nicht für Luftfracht zugelassen.**

Prevents baked goods from sticking to baking moulds – or sheet. 100 % pure foodstuff and neutral taste.

For professional use only. Not permitted for transport via Airfreight.

Art.-Nr./code	Volumen/volume (ml)	Treibmittel/gas	VE/unit
266950	200	CO ₂ -Ethanol	12
266960	500	Butan/Propan	12





d	BACKHANDSCHUHE
gb	BAKING MITTENS
it	GUANTI DA FORNO
es	GUANTES-MANOPLAS ANTICALORICAS

Spezial-Baumwollgewebe, Farbe natur, Innenhand und Daumen verstärkt
 hitzebeständig bis + 200 °C,
 waschmaschinenfest bis + 40 °C

*special cotton fabric, natural colour, reinforced palm and thumb
 heat resistant up to + 200 °C,
 machine-washable up to + 40 °C*

Art.-Nr./code	Länge/length (mm)	Breite/width (mm)	VE/unit
310001	270	150	1 Paar



d	BACKHANDSCHUHE MIT LANGEN STULPEN
gb	BAKING MITTENS LONG CUFFS
it	GUANTI DA FORNO CON POLSINI LUNGHI
es	GUANTES-MANOPLAS ANTICALORICAS CON PUÑOS LARGOS

Spezial-Baumwollgewebe, Farbe natur, Innenhand und Daumen verstärkt
 hitzebeständig bis + 200 °C,
 waschmaschinenfest bis + 40 °C

*special cotton fabric, natural colour, reinforced palm and thumb
 heat resistant up to + 200 °C,
 machine-washable up to + 40 °C*

Art.-Nr./code	Länge/length (mm)	Breite/width (mm)	VE/unit
310003	400	150	1 Paar



d	BACKHANDSCHUHE LEDER MIT STULPEN
gb	BAKING MITTENS LEATHER WITH CUFFS
it	GUANTI DA FORNO IN CUIOIO CON POLSINI
es	GUANTES-MANOPLAS ANTICALORICAS EN CUERO CON PUÑOS

Leder, gefüttert,
 extrem hitzebeständig bis + 250 °C,
 nicht waschmaschinenfest

*leather, inner lining,
 extremely heat resistant up to + 250 °C,
 not machine-washable*

Art.-Nr./code	Länge/length (mm)	Breite/width (mm)	VE/unit
310011	450	140	1 Paar



d	EINWEGHANDSCHUHE
gb	GLOVES "ONE USE"
it	GUANTI MONOUSO
es	GUANTES DESECHABLES

Material: PE, transparent, geprägt,
 im Spenderkarton à 100 Stück

*Made of PE, transparent embossed,
 in dispenser box à 100 pieces*

Art.-Nr./code	Größe/size	Länge/length (mm)	VE/unit
391500	S "small"	275	100
391510	M "medium"	280	100
391520	L "large"	285	100

FOLIEN-ABREISSVORRICHTUNG EINFACH	d
CLINGFILM TEAR-OFF-DISPENSER SINGLE	gb
PORTA PELLICOLA, SEMPLICE	it
SOPORTE PARA FILM ESTIRABLE, SIMPLE	es

aus Metall, stabile Ausführung, mit Säge
für Endlosfolien Ø max. 80 mm

*made of metal, with saw, for endless
rolls; Ø max. 80 mm*



Art.-Nr./code	for Folienbreite/for clingfilm width (mm)	Ausführung/type	VE/unit
158110	300	einfach / single	1
158120	450	einfach / single	1
158130	600	einfach / single	1



FRISCHHALTEFOLIE "EUROFOL" - ENDLOS	d
CLINGFILM "EUROFOL" - ENDLESS	gb
PELLICOLA ADESIVA EUROFOL, CONTINUA	it
FILM ESTIRABLE EUROFOL, CONTINUO	es

Material: lebensmittelechte Haftfolie (PE)
Materialstärke: 10 µ
gute Hafteigenschaften, atmungsaktiv, geeignet
auch zum Verpacken fetthaltiger Produkte

*high quality clingfilm (PE)
thickness: 10 µ
excellent adhesive strength
usable also for greasy products*



Art.-Nr./code	Breite /width (mm)	Lauflänge/length (m)	VE/unit
131800	290	300	4
131801	440	300	4
131802	590	300	4



d	BACKFORMEN AUS SILIKON 300 x 175 mm
gb	BAKING MOULDS MADE OF SILICONE 300 x 175 mm
it	STAMPI IN SILICONE 300 x 175 mm
es	MOLDES EN SILICONA 300 x 175 mm

Material: hochwertiges und lebensmittel-echtes Silikon, mit Antihafteffekt – kein vorheriges Einfetten mehr notwendig!
 Temperaturbereich: -60 bis +230 °C (für Backöfen, Mikrowelle oder Gefrierschränke)
 Größe einer Backform: 175 x 300 mm (GN1/3)

Made of high quality and non-sticking silicone - without prior greasing!
 Temperature range: from -60 to +230 °C (for ovens, microwaves and freezers)
 Size of one baking mould: 175 x 300 mm (GN 1/3)

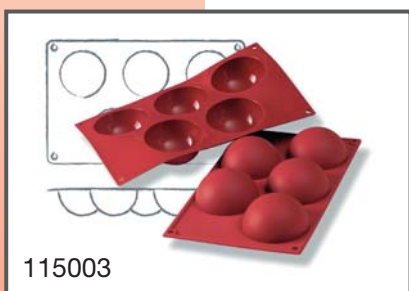
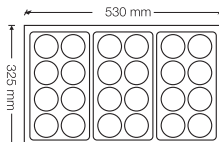

115003

d	HALBKUGEL
gb	HALF-SPHERES
it	SEMISFERE
es	SEMIESFERAS

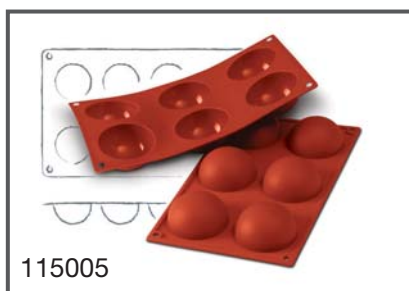

115005

d	HALBKUGEL
gb	HALF-SPHERES
it	SEMISFERE
es	SEMIESFERAS

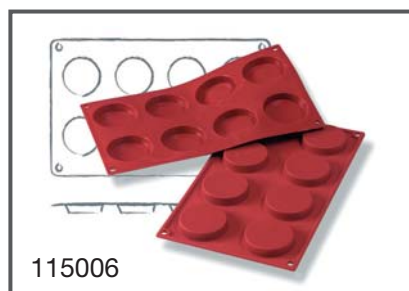

115006

d	FLORENTINER
gb	FLORENTINS
it	FIorentINE
es	FLORENTINAS



115007

d	SAVARIN
gb	SAVARIN
it	SAVARIN
es	SAVARIN

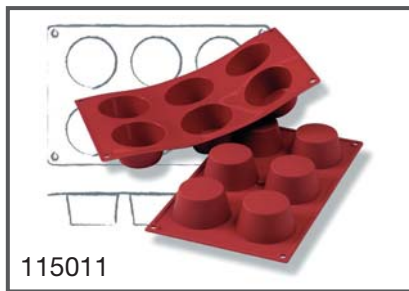

115011

d	MUFFIN
gb	MUFFINS
it	MUFFIN
es	MUFFIN

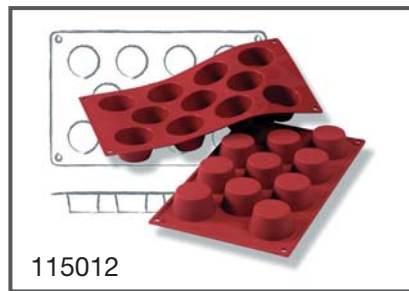

115012

d	MUFFIN MINI
gb	MUFFINS MINI
it	MUFFIN MINI
es	MUFFIN MINI



115131

d	MUFFIN GROSS
gb	MUFFIN BIG
it	MUFFIN
es	MUFFIN

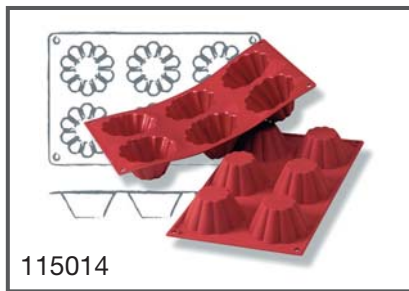

115014

d	BRIOCHE
gb	BRIOCHE
it	BRIOCLETTE
es	BRIOCHETTES

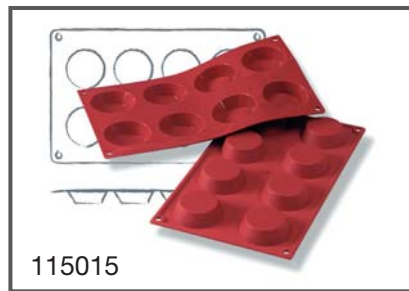

115015

d	TORTELETT
gb	TARTLETS
it	TARTELETTE
es	TARTELETA GRANDE

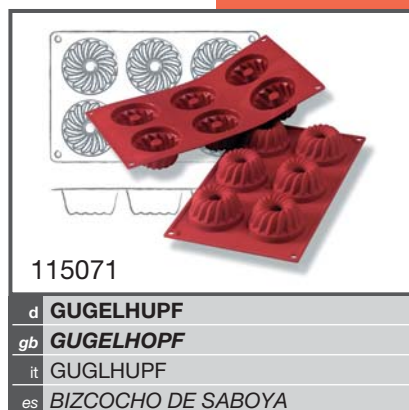
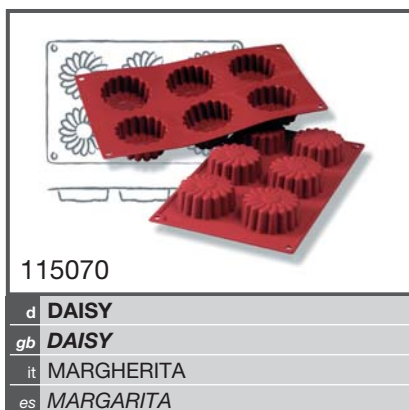
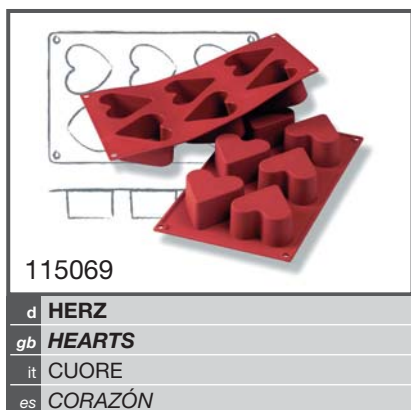
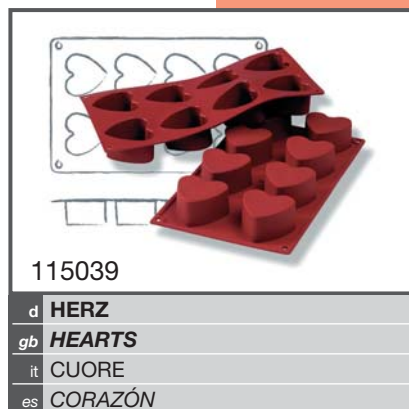
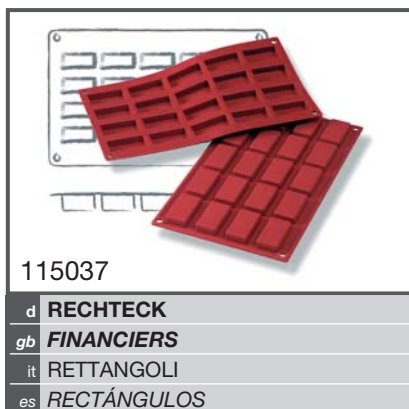
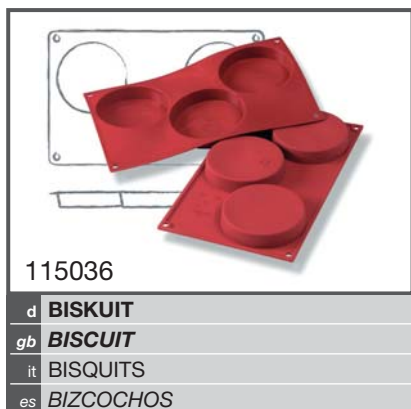
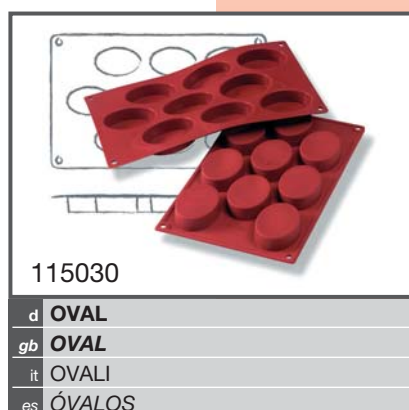
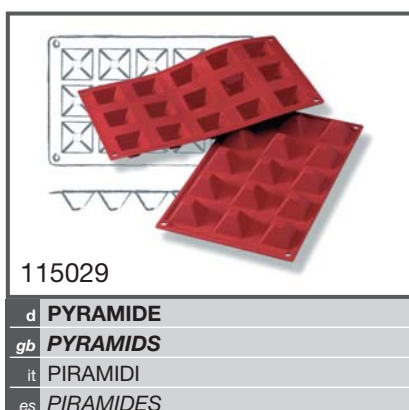
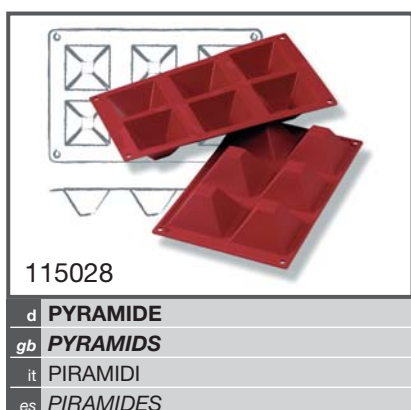
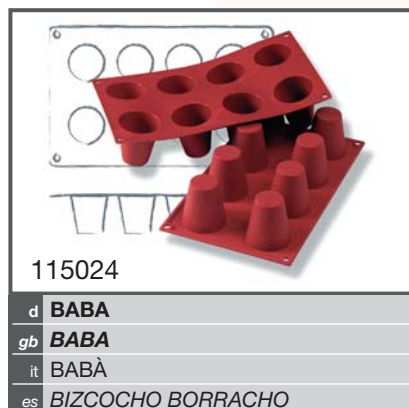
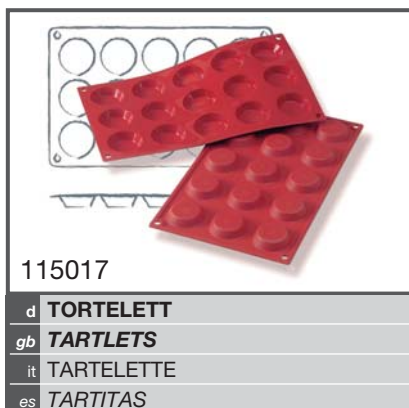
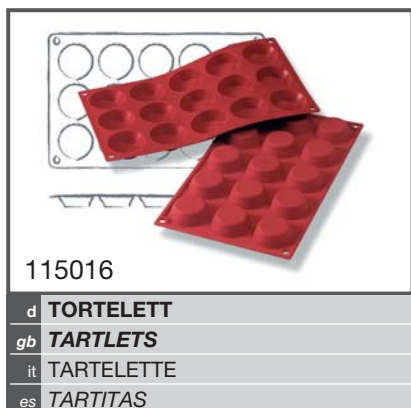



115072

d	GUGELHUPF
gb	GUGELHOPF
it	GUGELHOPF
es	BIZCOCHO DE SABOYA



115118

d	KRAPFEN
gb	KRAPFEN
it	KRAPFEN
es	EL BOLLO



115086

d	KUSS
gb	KISS
it	BACIO
es	EL BESO



115087

d	VULKAN
gb	VULKANO
it	VULCANO
es	VOLCÁN



115088

d	VULKAN
gb	VULKANO
it	VULCANO
es	VOLCÁN



115089

d	VULKAN
gb	VULKANO
it	VULCANO
es	VOLCÁN



115090

d	HERZ "PASSION"
gb	HEART "PASSION"
it	CUORE "PASSION"
es	CORAZÓN "PASIÓN"



115091

d	HERZ "PASSION"
gb	HEART "PASSION"
it	CUORE "PASSION"
es	CORAZÓN "PASIÓN"



115092

d	HERZ "PASSION"
gb	HEART "PASSION"
it	CUORE "PASSION"
es	CORAZÓN "PASIÓN"



115093

d	ROSE
gb	ROSE
it	ROSA
es	ROSA



115094

d	ROSE
gb	ROSE
it	ROSA
es	ROSA



1115098

d	KUBUS
gb	CUBE
it	CUBO
es	EL CUBO

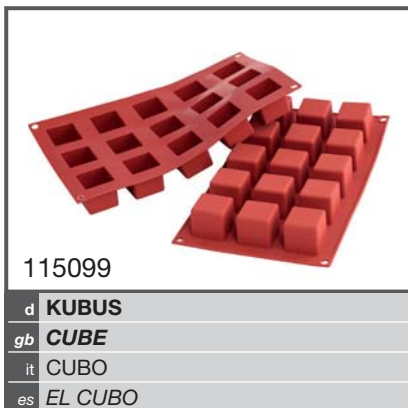

115099

d **KUBUS**
 gb **CUBE**
 it CUBO
 es **EL CUBO**

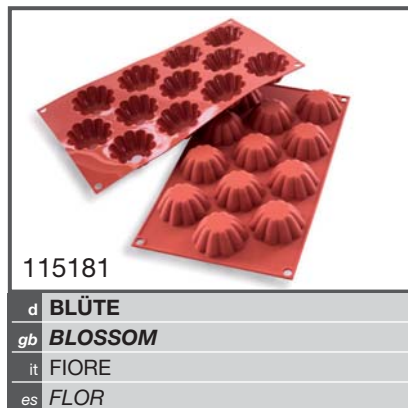

115181

d **BLÜTE**
 gb **BLOSSOM**
 it FIORE
 es **FLOR**

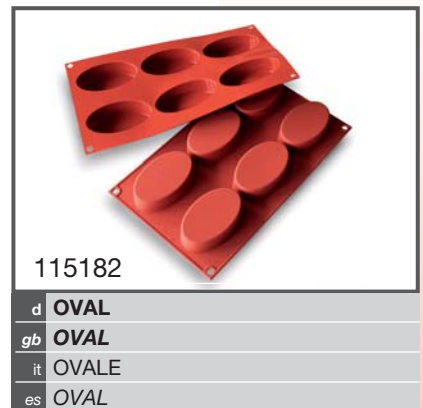

115182

d **OVAL**
 gb **OVAL**
 it OVALE
 es **OVAL**

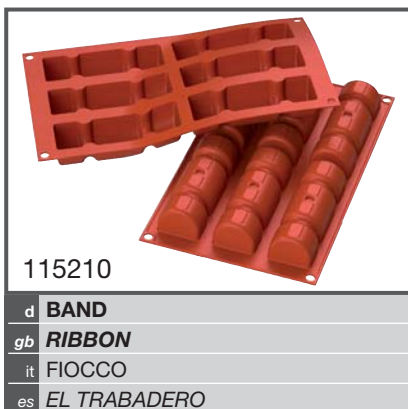

115210

d **BAND**
 gb **RIBBON**
 it FIOCCO
 es **EL TRABADERO**

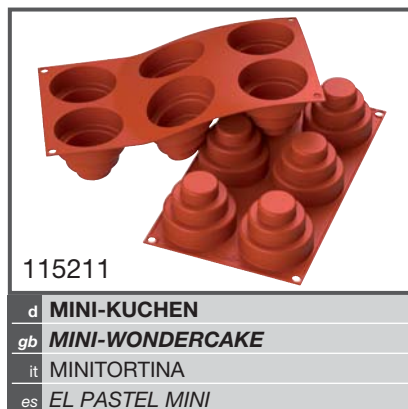

115211

d **MINI-KUCHEN**
 gb **MINI-WONDERCAKE**
 it MINITORTINA
 es **EL PASTEL MINI**

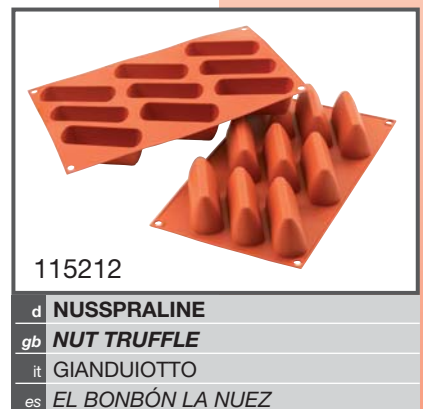

115212

d **NUSSPRALINE**
 gb **NUT TRUFFLE**
 it GIANDUIOTTO
 es **EL BONBÓN LA NUEZ**



115213

d **MULDE**
 gb **HOLLOW**
 it TINOZZA
 es **CUBETA**

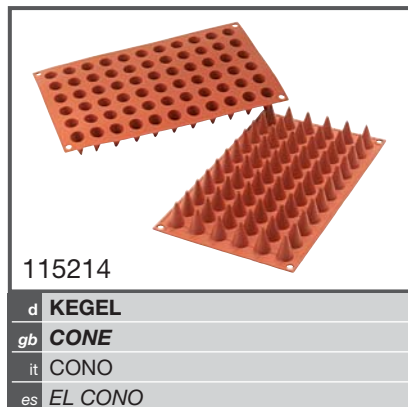

115214

d **KEGEL**
 gb **CONE**
 it CONO
 es **EL CONO**



115215

d **MINI FANTASY**
 gb **MINI FANTASY**
 it MINI FANTASY
 es **MINI FANTASY**



115216

d **WINTERMÄRCHEN**
 gb **MAGIC WINTER**
 it INVERNO
 es **EL INVIERNO**

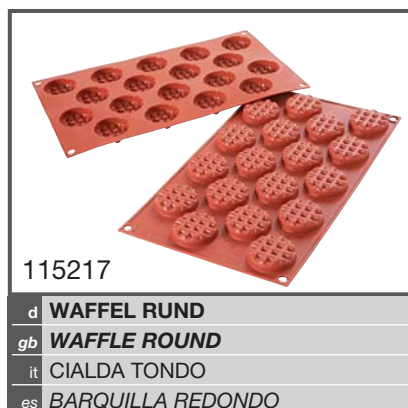

115217

d **WAFFEL RUND**
 gb **WAFFLE ROUND**
 it CIALDA TONDO
 es **BARQUILLA REDONDO**



115218

d **WAFFEL QUADRAT**
 gb **WAFFLE SQUARE**
 it CIALDA QUADRATO
 es **BARQUILLA CUADRADA**

d	RODONFORM - MIT GLATTEM RAND
gb	RODON MOULD - WITH PLAIN RIM
it	STAMPO AMERICANO CON BORDO LISCIO
es	MOLDE DE KUGELHOPF - CON BORDE LISO



Art.-Nr./code	ø (mm)
901314	140
901316	160
901318	180
901320	200
901322	220
901324	240
901326	260

d	RODONFORM - MIT GERIPPTEM RAND
gb	RODON MOULD - WITH WAVY RIM
it	STAMPO AMERICANO - CON BORDO FESTONATO
es	MOLDE DE KUGELHOPF - CON BORDE RIZADO



Art.-Nr./code	ø (mm)
903014	140



d	GUGELHUPF-FORM
gb	GUGELHUPF-MOULD
it	STAMPO DA GUGLHUPF
es	MOLDE DE KUGELHOPF



Art.-Nr./code	ø (mm)
930020	200

d	SANDKRAZFORM - MIT GLATTEM BODEN
gb	SPONGE-CAKE MOULD - WITH PLAIN BOTTOM
it	TORTIERA SAVARIN CON FONDO LISCIO
es	MOLDE TROIS FRÈRES - CON FONDO LISO



Art.-Nr./code	ø (mm)
926820	200
926822	220
926824	240
926826	260
926828	280

d	FRANKFURTER KRAZFORM
gb	SPONGE-CAKE MOULD
it	TORTIERA TROIS FRÈRES
es	MOLDE TROIS FRÈRES



Art.-Nr./code	ø (mm)
915120	200
915122	220
915124	240
915126	260

d	SPRINGFORM
gb	SPRING-CAKE MOULD
it	STAMPO APRIBILE
es	MOLDE TARTA DESMONTABLE



Art.-Nr./code	ø (mm)
900020	200
900024	240
900026	260

d	ROHRBODEN FÜR SPRINGFORMEN
gb	BOTTOM WITH TUBE FOR SPRING-CAKE MOULDS
it	FONDO CIAMBELLA PER STAMPO APRIBILE
es	FONDO SAVARIN PARA MOLDE TARTA DESMONTABLE



Art.-Nr./code	ø (mm)
900126	260



d	SPRINGFORM-SET
gb	SPRING-CAKE MOULD-SET
it	STAMPO APRIBILE, SET CON 2 FONDI
es	MOLDE TARTA DESMONTABLE, JUEGO CON 2 FONDOS



Art.-Nr./code	ø (mm)
905026	260
905028	280

d	SPRINGBLECH - KONISCH
gb	SPRING-CAKE MOULD - CONICAL
it	STAMPO APRIBILE - CONICO
es	MOLDE TARTA DESMONTABLE - CÓNICO



Art.-Nr./code	ø (mm)
902028	280
902032	320



d	TORTENFORM
gb	FANCY CAKE MOULD
it	STAMPO DA TORTA FANTASIA
es	MOLDE TARTA FANTASÍA



Art.-Nr./code	ø (mm)
931524	240
931526	260

d	HERZFORM
gb	HEART MOULD
it	SXTAMPO CUORE
es	MOLDE CORAZÓN



Art.-Nr./code	ø (mm)
940025	250
940027	270



d	STERNFORM
gb	STAR MOULD
it	STAMPO DA STELLA
es	MOLDE ESTRELLA



Art.-Nr./code	ø (mm)
931026	260



d	KUCHENBLECH
gb	CAKE MOULD
it	TORTIERA TONDA
es	MOLDE REDONDO



Art.-Nr./code	ø (mm)
904024	240
904026	260
904028	280
904030	300
904032	320
904034	340

d	PIZZABLECH
gb	PIZZA MOULD
it	STAMPO DA PIZZA
es	MOLDE PARA PIZZA



Art.-Nr./code	ø (mm)
904524	240
904526	260

d	OBSTTORTENFORM - MIT GERIPPTEM RAND
gb	FRUIT FLAN PAN - WITH WAVY RIM
it	TORTIERA - CON BORDO FESTONATO
es	MOLDE TARTA - CON BORDE RIZADO



Art.-Nr./code	ø (mm)
950030	300



d	OBSTTORTENFORM
gb	FRUIT FLAN PAN
it	TORTIERA
es	MOLDE TARTA



Art.-Nr./code	ø (mm)
949908	80
949910	100
949912	120
949928	280
949930	300
949932	320

d	KÄSETORTENFORM - MIT GERADEM RAND
gb	CHEESE FLAN PAN - WITH STRAIGHT RIM
it	TORTIERA TONDA - CON BORDO DRITTO
es	MOLDE REDONDO - CON BORDE DERECHO



Art.-Nr./code	ø (mm)
967028	280

d	WOLFSZAHNFORM
gb	"TOOTH OF WOLF" SHEET
it	PLACCA DENTI DI LUPO
es	PLACA PARA BAGUETTES



Art.-Nr./code	(mm)
920000	350 x 330

d	BRIOCHEFORM
gb	BRIOCHE MOULD
it	TARTELLETE A BRIOCHE
es	MOLDES BRIOCHE



Art.-Nr./code	ø (mm)
951012	120
951014	140
951016	160

d	KÖNIGSKUCHENFORM
gb	LOAF CAKE MOULD
it	TORTIERA RETTANGOLARE
es	MOLDE PLUMCAKE



Art.-Nr./code	(mm)
910020	90 x 200
910025	100 x 250
910030	110 x 300
910035	120 x 350

d	RIEFENFORM
gb	RIDGED BAKING MOULD
it	TORTIERA RETTANGOLARE FESTONATA
es	MOLDE MEDIA CAÑA RECTANGULAR ONDULADO

Art.-Nr./code (mm)
955033 105 x 355



d	REHRÜCKENFORM
gb	RIDGED BAKING MOULD
it	TORTIERA RETTANGOLARE FESTONATA
es	MOLDE MEDIA CAÑA REDONDO ONDULADO

Art.-Nr./code (mm)
994628 110 x 280
994633 110 x 330



d	LAMM-FORM
gb	LAMB MOULD
it	TORTIERA "AGNELLO"
es	MOLDE TARTA "EL BORREGO"

Art.-Nr./code (mm)
967030 220 x 260



d	LAMM-FORM
gb	LAMB MOULD
it	TORTIERA "AGNELLO"
es	MOLDE TARTA "EL BORREGO"

Art.-Nr./code (mm)
965020 210 x 150



d	IGELFORM
gb	"HEDGEHOG" MOULD
it	STAMPO RICCIO
es	MOLDE FORMA ERIZO

Art.-Nr./code ø (mm)
977708 80
977710 100
977715 150
977720 200



d	OSTERHASEN-FORM
gb	EASTER BUNNY MOULD
it	TORTIERA "CONIGLIETTO DI PASQUA"
es	MOLDE TARTA "CONEJITO DE PASCUA"

Art.-Nr./code (mm)
965000 185 x 140
965010 260 x 180



d	IGELFAMILIE
gb	"HEDGEHOG" FAMILY
it	FAMIGLIA DI RICCI
es	FAMILIA DE ERIZOS

Art.-Nr./code
977705



d	SPRINGFORM
gb	SPRING-CAKE MOULD
it	STAMPO APRIBILE, SMALTATO
es	MOLDE TARTA DESMONTABLE, ESMALTADO

Art.-Nr./code Ø (mm)
980020 200
980024 240
980026 260
980028 280



d	WEIHNACHTSSTERN-FORM
gb	CHRISTMAS STAR MOULD
it	TORTIERA STELLA DI NATALE
es	MOLDE ESTRELLA DE NAVIDAD

Art.-Nr./code (mm)
967040 150 x 340



d	SPRINGBLECH - KONISCH
gb	SPRING-CAKE MOULD - CONICAL
it	STAMPO APRIBILE - CONICO
es	MOLDE TARTA DESMONTABLE - CÓNICO

Art.-Nr./code ø (mm)
982028 280
982032 320



d	KASTENFORM/BROTBACKFORM
gb	BREAD MOULD
it	STAMPO DA PANE
es	MOLDE PARA PAN



Art.-Nr./code	(mm)
912030	110 x 300
912035	120 x 350

d	6-MUFFIN-FORM
gb	6-CUP MUFFIN PAN
it	PLACCA DA 6 MUFFIN
es	PLACA DE MOLDES PARA 6 MUFFINS



Art.-Nr./code	(mm)
960010	290 x 190

d	SPRINGFORM-BODEN
gb	BOTTOM FOR SPRING-CAKE MOULD
it	FONDO PER STAMPO APRIBILE, SMALTATO
es	FONDO PARA MOLDE TARTA DESMONTABLE



Art.-Nr./code	ø (mm)
981026	260
981028	280

d	12-MUFFIN-FORM
gb	12-CUP MUFFIN PAN
it	PLACCA DA 12 MUFFIN
es	PLACA DE MOLDES PARA 12 MUFFINS



Art.-Nr./code	(mm)
960020	370 x 242

d	PIZZABLECH
gb	PIZZA MOULD
it	STAMPO DA PIZZA, SMALTATO
es	MOLDE PARA PIZZA, ESMALTADO



Art.-Nr./code	ø (mm)
981030	280

d	6-MUFFIN-FORM „HALLOWEEN“
gb	6-CUP MUFFIN PAN "HALLOWEEN"
it	PLACCA DA 6 MUFFIN "HALLOWEEN"
es	PLACA DE MOLDES PARA 6 MUFFINS



Art.-Nr./code	(mm)
960030	380 x 284

d	KUCHENBLECH
gb	CAKE MOULD
it	TORTIERA TONDA, SMALTATA
es	MOLDE REDONDO, ESMALTADO



Art.-Nr./code	ø (mm)
981040	300
981041	320

d	QUICHE-FORM
gb	"QUICHE" MOULD
it	TORTIERA TONDA
es	MOLDE REDONDO



Art.-Nr./code	ø (mm)
981050	300





d	AUSSTECHERSATZ 9-TEILIG, RUND, GLATT
gb	SET OF PASTRY CUTTERS 9 PIECES, ROUND, PLAIN
it	SET DI TAGLIAPASTA (9 PZ.), ANELLO LISCIO
es	JUEGO DE CORTAPASTA (9 U.) REDONDOS LISOS

Material: Nylon, hitzebeständig bis +160°C made of nylon, heat resistant up to +160°C; height: 35 mm
 Höhe: 35 mm

Art.-Nr./code	Durchmesser / diameter	VE/unit
166100	20, 30, 40, 50, 60, 70, 80, 90, 100 mm	1



d	AUSSTECHERSATZ 9-TEILIG, RUND, GEZACKT
gb	SET OF PASTRY CUTTERS 9 PIECES, ROUND, SERRATED
it	SET DI TAGLIAPASTA (9 PZ.), ANELLO FESTONATO
es	JUEGO DE CORTAPASTA (9 U.) REDONDOS RIZADOS

Material: Nylon, hitzebeständig bis +160°C made of nylon, heat resistant up to +160°C; height: 35 mm
 Höhe: 35 mm

Art.-Nr./code	Durchmesser / diameter	VE/unit
166101	20, 30, 40, 50, 60, 70, 80, 90, 100 mm	1



d	AUSSTECHERSATZ 9-TEILIG, QUADRAT, GLATT
gb	SET OF PASTRY CUTTERS 9 PIECES, SQUARE, PLAIN
it	SET DI TAGLIAPASTA (9 PZ.), QUADRATO LISCIO
es	JUEGO DE CORTAPASTA (9 U.) CUADRADO LISOS

Material: Nylon, hitzebeständig bis +160°C made of nylon, heat resistant up to +160°C; height: 35 mm
 Höhe: 35 mm

Art.-Nr./code	Durchmesser / diameter	VE/unit
166102	19 / 28 / 37 / 47 / 57 / 67 / 76 / 86 / 95 mm	1



d	AUSSTECHERSATZ 9-TEILIG, QUADRAT, GEZACKT
gb	SET OF PASTRY CUTTERS 9 PIECES, SQUARE, SERRATED
it	SET DI TAGLIAPASTA (9 PZ.), QUADRATO FESTONATO
es	JUEGO DE CORTAPASTA (9 U.) CUADRADO RIZADOS

Material: Nylon, hitzebeständig bis +160°C made of nylon, heat resistant up to +160°C; height: 35 mm
 Höhe: 35 mm

Art.-Nr./code	Durchmesser / diameter	VE/unit
166103	19 / 28 / 37 / 47 / 57 / 67 / 76 / 86 / 95 mm	1

AUSSTECHERSATZ 7-TEILIG, HERZ, GLATT	d
SET OF PASTRY CUTTERS 7 PIECES, HEART, PLAIN	gb
SET DI TAGLIAPASTA (7 PZ.) LISCI CUORE	it
JUEGO DE CORTAPASTA (7 U.) CORAZÓN LISOS	es

Material: Nylon, hitzebeständig bis +160°C made of nylon, heat resistant
 Höhe: 35 mm up to +160°C; height: 35 mm

Art.-Nr./code	Durchmesser / diameter	VE/unit
166104	120 x 115 / 105 x 100 / 90 x 85 / 75 x 70 / 65 x 55 / 45 x 40 / 30 x 25 mm	1



AUSSTECHERSATZ 7-TEILIG, HERZ, GEZACKT	d
SET OF PASTRY CUTTERS 7 PIECES, HEART, SERRATED	gb
SET DI TAGLIAPASTA (7 PZ.) FESTONATI CUORE	it
JUEGO DE CORTAPASTA (7 U.) CORAZÓN RIZADOS	es

Material: Nylon, hitzebeständig bis +160°C made of nylon, heat resistant
 Höhe: 35 mm up to +160°C; height: 35 mm

Art.-Nr./code	Durchmesser / diameter	VE/unit
166105	120 x 115 / 105 x 100 / 90 x 85 / 75 x 70 / 65 x 55 / 45 x 40 / 30 x 25 mm	1



AUSSTECHERSATZ 7-TEILIG, HALBMOND, GLATT	d
SET OF PASTRY CUTTERS 7 PIECES, HALF MOON, PLAIN	gb
SET DI TAGLIAPASTA (7 PZ.) LISCI MEZZALUNA	it
JUEGO DE CORTAPASTA (7 U.) CRECIENTE LISOS	es

Material: Nylon, hitzebeständig bis +160°C made of nylon, heat resistant
 Höhe: 35 mm up to +160°C; height: 35 mm

Art.-Nr./code	Durchmesser / diameter	VE/unit
166106	69 x 20 / 80 x 28 / 90 x 35 / 98 x 43 / 100 x 50 / 110 x 58 / 114 x 65 mm	1



AUSSTECHERSATZ 7-TEILIG HALBMOND, GEZACKT	d
SET OF PASTRY CUTTERS 7 PIECES, HALF MOON, SERRATED	gb
SET DI TAGLIAPASTA (7 PZ.) FESTONATI MEZZALUNA	it
JUEGO DE CORTAPASTA (7 U.) CRECIENTE RIZADOS	es

Material: Nylon, hitzebeständig bis +160°C made of nylon, heat resistant
 Höhe: 35 mm up to +160°C; height: 35 mm

Art.-Nr./code	Durchmesser / diameter	VE/unit
166107	69 x 20 / 80 x 28 / 90 x 35 / 98 x 43 / 100 x 50 / 110 x 58 / 114 x 65 mm	1





d	AUSSTECHERSATZ 7-TEILIG, OVAL, GLATT
gb	SET OF PASTRY CUTTERS 7 PIECES, OVAL, PLAIN
it	SET DI TAGLIAPASTA (7 PZ.) OVALE LISCIO
es	JUEGO DE CORTAPASTA (7 U.) OVAL LISOS

Material: Nylon, hitzebeständig bis +160°C made of nylon, heat resistant up to +160°C; height: 35 mm
 Höhe: 35 mm

Art.-Nr./code	Durchmesser / diameter	VE/unit
166108	21 x 10 / 35 x 20 / 50 x 30 / 65 x 35 / 80 x 45 / 95 x 55 / 110 x 65 mm	1



d	AUSSTECHERSATZ 7-TEILIG, OVAL, GEZACKT
gb	SET OF PASTRY CUTTERS 7 PIECES, OVAL, SERRATED
it	SET DI TAGLIAPASTA (7 PZ.) OVALE FESTONATO
es	JUEGO DE CORTAPASTA (7 U.) OVAL RIZADOS

Material: Nylon, hitzebeständig bis +160°C made of nylon, heat resistant up to +160°C; height: 35 mm
 Höhe: 35 mm

Art.-Nr./code	Durchmesser / diameter	VE/unit
166109	21 x 10 / 35 x 20 / 50 x 30 / 65 x 35 / 80 x 45 / 95 x 55 / 110 x 65 mm	1



d	AUSSTECHERSATZ 7-TEILIG, STERN, GLATT
gb	SET OF PASTRY CUTTERS 7 PIECES, STAR, PLAIN
it	SET DI TAGLIAPASTA (7 PZ.) STELLA LISCIO
es	JUEGO DE CORTAPASTA (7 U.) ESTRELLA LISOS

Material: Nylon, hitzebeständig bis +160°C made of nylon, heat resistant up to +160°C; height: 35 mm
 Höhe: 35 mm

Art.-Nr./code	Durchmesser / diameter	VE/unit
166110	130 x 115 / 115 x 100 / 100 x 85 / 85 x 70 / 70 x 60 / 55 x 45 / 40 x 35 mm	1





AUSSTECHER IM SATZ (9-TEILIG)	d
SET OF PASTRY CUTTERS (9 PIECES) ROUND, PLAIN	gb
SET DI TAGLIAPASTA (9 PZ.), ANELLO LISCIO	it
JUEGO DE CORTAPASTA (9 U.) REDONDOS LISOS	es

Material: Edelstahl, Materialstärke: 0,4 – 0,5 mm, *made of stainless steel,*
 Höhe: 30 mm *thickness: 0,4 – 0,5 mm; height: 30 mm*

Art.-Nr./code	Ausführung / type	VE/unit
199500	rund, glatt / round, plain 30, 40, 50, 60, 70, 80, 90, 100, 110 mm	1 Set



AUSSTECHER IM SATZ (16-TEILIG) RUND, GLATT	d
SET OF PASTRY CUTTERS (16 PIECES) ROUND, PLAIN	gb
SET DI TAGLIAPASTA (16 PZ.), ANELLO LISCIO	it
JUEGO DE CORTAPASTA (16 U.) REDONDOS LISOS	es

Material: Edelstahl, Materialstärke: 0,4 – 0,5 mm, *made of stainless steel,*
 Höhe: 30 mm *thickness: 0,4 – 0,5 mm; height: 30 mm*

Art.-Nr./code	Ausführung / type	VE/unit
199501	rund, glatt / round, plain 20, 30, 40, 50, 60, 70, 75, 80, 85, 90, 95, 100, 110, 120, 125, 140 mm	1 Set





d	SCHAUMSPEISERINGE-SET / QUADTRAT
gb	MOUSSE-FRAME-SET / SQUARE
it	SET QUADRATI PER DOLCI
es	JUEGO DE CUADRADOS PARA POSTRES

Material: Edelstahl *stainless steel*
 3 Formen + 1 Drücker *3 frames + 1 pusher*

Art.-Nr./code	Abmessung/dimensions (mm)	VE/unit
166500	55	1 Set



d	SCHAUMSPEISERINGE-SET / DREIECK
gb	MOUSSE-FRAME-SET / TRIANGLE
it	SET TRIANGOLI PER DOLCI
es	JUEGO DE TRIANGULOS PARA POSTRES

Material: Edelstahl *stainless steel*
 3 Formen + 1 Drücker *3 frames + 1 pusher*

Art.-Nr./code	Abmessung/dimensions (mm)	VE/unit
166501	55	1 Set

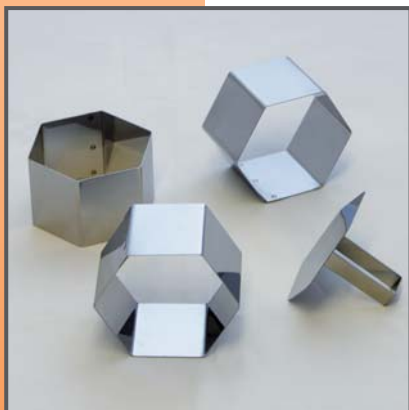

d	SCHAUMSPEISERINGE-SET / SECHSECK
gb	MOUSSE-FRAME-SET / HEXAGON
it	SET ESAGONI PER DOLCI
es	JUEGO DE HEXAGONOS PARA POSTRES

Material: Edelstahl *stainless steel*
 3 Formen + 1 Drücker *3 frames + 1 pusher*

Art.-Nr./code	Abmessung/dimensions (mm)	VE/unit
166502	75	1 Set



d	SCHAUMSPEISERINGE-SET / RUND
gb	MOUSSE-FRAME-SET / ROUND
it	SET ANELLI TONDI PER DOLCI
es	JUEGO DE AROS REDONDOS PARA POSTRES

Material: Edelstahl *stainless steel*
 3 Formen + 1 Drücker *3 frames + 1 pusher*

Art.-Nr./code	Abmessung/dimensions (mm)	VE/unit
166503	55	1 Set

SCHAUMSPEISERINGE-SET / HERZ	d
MOUSSE-FRAME-SET / HEART	gb
SET CUORI PER DOLCI	it
JUEGO DE CORAZONES PARA POSTRES	es

Material: Edelstahl *stainless steel*
 3 Formen + 1 Drücker *3 frames + 1 pusher*

Art.-Nr./code	Abmessung/dimensions (mm)	VE/unit
166504	75	1 Set



SCHAUMSPEISERINGE-SET / OVAL	d
MOUSSE-FRAME-SET / OVAL	gb
SET OVALI PER DOLCI	it
JUEGO DE OVALOS PARA POSTRES	es

Material: Edelstahl *stainless steel*
 3 Formen + 1 Drücker *3 frames + 1 pusher*

Art.-Nr./code	Abmessung/dimensions (mm)	VE/unit
166505	78	1 Set





d SCHAUMSPEISERINGE-SET / RECHTECK ABGERUNDET
gb MOUSSE-FRAME-SET / RECTANGULAR CURVED
it SET RETTANGOLI ARROTONDATI PER DOLCI
es JUEGO DE RECTANGULOS REDONDEADOS PARA POSTRES

Material: Edelstahl *stainless steel*
 3 Formen + 1 Drücker *3 frames + 1 pusher*

Art.-Nr./code	Abmessung/dimensions (mm)	VE/unit
166506	68	1 Set



d SCHAUMSPEISERINGE-SET / DREIECK ABGERUNDET
gb MOUSSE-FRAME-SET / TRIANGULAR CURVED
it SET TRIANGOLI ARROTONDATI PER DOLCI
es JUEGO DE TRIANGULOS REDONDEADOS PARA POSTRES

Material: Edelstahl *stainless steel*
 3 Formen + 1 Drücker *3 frames + 1 pusher*

Art.-Nr./code	Abmessung/dimensions (mm)	VE/unit
166507	65	1 Set



d SCHAUMSPEISERINGE-SET / QUADRAT ABGERUNDET
gb MOUSSE-FRAME-SET / SQUARE CURVED
it SET QUADRATI ARROTONDATI PER DOLCI
es JUEGO DE CUADRADOS REDONDEADOS PARA POSTRES

Material: Edelstahl *stainless steel*
 3 Formen + 1 Drücker *3 frames + 1 pusher*

Art.-Nr./code	Abmessung/dimensions (mm)	VE/unit
166508	65	1 Set



d SCHAUMSPEISERINGE-SET / TROPFEN
gb MOUSSE-FRAME-SET / DROP
it SET GOCCIE PER DOLCI
es JUEGO DE GOTAS PARA POSTRES

Material: Edelstahl *stainless steel*
 3 Formen + 1 Drücker *3 frames + 1 pusher*

Art.-Nr./code	Abmessung/dimensions (mm)	VE/unit
166509	73	1 Set

SCHOKOLADEN-FONTÄNE	d
CHOCOLATE FOUNTAIN	gb
FONTANA CIOCCOLATO	it
FUENTE CHOCOLATE	es

Material: Edelstahl *made of stainless steel*
 Gewicht: 5,5 kg *weight: 5,5 kg; temperatur*
 Temperatur von 0 bis 80 °C einstellbar *adjustable between 0 and 80 °C*
 Bodendurchmesser 33 cm *bottom diameter: 33 cm*
 240 Volt *240 volt*

Art.-Nr./code	Höhe/height	Kapazität/capacity	Leistung/power	VE/unit
255320	600	2,5 kg	150 W	1



Temperatur regelbar *temperature adjustable*
 Material: Edelstahl *made of stainless steel*
 Gewicht: 8 kg; 240 Volt; 50 Hz *weight: 8 kg; 240 volt; 50 Hz*

Art.-Nr./code	Höhe/height	Kapazität/capacity	Leistung/power	VE/unit
255350	800 mm	5–6 kg	215 W	1





d	MESSBECHER
gb	MEASURING CUPS
it	CARAFFE GRADUATE, MANIGLIA CHIUSA
es	JARRAS GRADUADAS, ASA CERRADA

Material: PP, Farbe natur, mit geschlossenem Griff, geprägter Skala und blauem Skalendruck, Liter- und Milliliter-Einteilung, bis 95°C erhitzenbar
made of PP, translucent, closed handle, with stamped and blue printed litre and ml scale, temperature resistant up to 95°C

Art.-Nr./code	Inhalt / volume (l)	VE/unit
206010	0,12	10
200010	0,25	25
200011	0,5	16
200012	1,0	12
200013	2,0	12
200014	3,0	10
200015	5,0	5



Material: PP, Farbe natur, mit offenem Griff, geprägter Skala und blauem Skalendruck, Liter- und Milliliter-Einteilung, bis 95°C erhitzenbar
made of PP, translucent, open handle, with stamped and blue printed litre and ml scale, temperature resistant up to 95°C

Art.-Nr./code	Inhalt / volume (l)	VE/unit
206011	0,5	16
206012	1,0	12
206013	2,0	12
206014	3,0	10
206015	5,0	5



d	TRICHTER
gb	FUNNELS
it	IMBUTI
es	EMBUDOS

Material: HD-PE, Farbe natur, gerade, mit Entlüftungslippen und Aufhängeöse
made of high density polyethylene, with suspension loop

Art.-Nr./code	ø (mm)	Auslaufende / run out ø (mm)	VE/unit
250001	50	3	1
250002	60	8	1
250003	80	11	1
250004	100	12	1
250005	120	12	1
250006	140	15	1
250007	164	17	1



d	MEHL- UND GEWÜRZSCHAUFELN
gb	FLOUR SCOOPS
it	SESSOLE BASE PIATTA, PE
es	RECOGEDORES LIBRADORES PARA HARINA, PE

Material: PE, Farbe natur
made of PE, transparent

Art.-Nr./code	Länge / length (mm)	Inhalt / volume (ml)	VE/unit
200023	187	110	12
200024	250	230	12
200025	310	470	6
200026	350	725	3
200027	400	1390	3

PORTIONIERER – MIT ERGONOMISCHEM KUNSTSTOFFGRIFF	d
FOOD SERVER – WITH ERGONOMIC PLASTIC HANDLE	gb
PORZIONATORI CON MANIGLIA ERGONOMICA	it
RACIONADORES HELADO CON MANGO ERGONÓMICO	es

Material: Edelstahl, ergonomischer Griff aus Kunststoff.

Made of stainless steel, with ergonomic plastic handle.

Anwendung: für Eis, Früchte, Reis, Mousse und andere Speisen.

Usable for ice cream, fruits, rice, mousse and other food.

Art.-Nr./code	Inhalt/volume (l)	ø (mm)	VE/unit
195010	1/8	80	1
195015	1/12	65	1
195020	1/16	61	1
195025	1/20	56	1
195030	1/24	51	1
195035	1/30	49	1
195040	1/36	46	1
195045	1/40	44	1
195050	1/50	42	1
195055	1/60	39	1
195060	1/100	30	1



PORTIONIERER	d
FOOD SERVER	gb
PORZIONATORI	it
RACIONADORES HELADO	es

Material: aus rostfreiem Edelstahl, schwere Profi-Qualität

made of stainless steel, heavy quality for professionals

Art.-Nr./code	Inhalt/volume (l)	Ø (mm)	VE/unit
195400	1/8	80	1
195405	1/12	67	1
195410	1/16	59	1
195415	1/20	56	1
195420	1/24	53	1
195425	1/30	50	1
195430	1/36	48	1
195435	1/40	44	1
195440	1/50	40	1

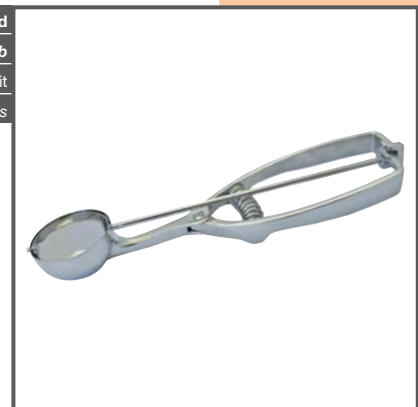

EISTÜTENHALTER	d
ICE CREAM CONE HOLDER	gb
PORTA CONI	it
PORTA CONOS DE HELADO	es

Material: Edelstahl, für 4 Eistüten

made of stainless steel, for 4 cones

Art.-Nr./code	ø Loch/hole (mm)	Höhe/height (mm)	VE/unit
190310	165	140	1





d	RÜHRSCHÜSSELN
gb	MIXING BOWLS
it	BACINELLE CONICHE, INOX
es	CALDEROS CÓNICOS, INOX

Material: Edelstahl, mit abgerundetem Rand *made of stainless steel, rolled edge*
 Schüsselform: konisch *cone-shaped*

Art.-Nr./code	ø (mm)	Inhalt / volume (l)	VE/unit
199002	160	0,5	1
199003	180	0,9	1
199004	200	1,2	1
199005	230	1,6	1
199006	240	2,0	1
199007	280	3,0	1
199008	290	5,0	1
199009	355	7,0	1
199010	395	8,2	1



d	SCHLAGSCHÜSSELN
gb	MIXING BOWLS
it	BACINELLE SEMISFERICHE, INOX
es	CALDEROS SEMIESFÉRICOS, INOX

Material: Edelstahl, mit abgerundetem Rand *made of stainless steel, rolled edge*
 Schüsselform: rund *round shape*

Art.-Nr./code	ø innen (mm)	Inhalt / volume (l)	VE/unit
199000	140	0,7	1
199011	160	1,0	1
199012	180	1,4	1
199013	200	1,9	1
199014	220	2,8	1
199015	240	3,8	1
199017	275	5,7	1
199018	300	7,6	1
199019	350	11,4	1

RÜHRSCHÜSELN	d
MIXING BOWLS	gb
BACINELLE TONDE, PLASTICA	it
CALDEROS SEMIESFÉRICOS, PLÁSTICO	es

Material: PP, natur-weiß, bruchsicher und hygienisch, stapelbar, auch für Mikrowellen-geräte geeignet

made of PP, natural white, break resistant, hygienic, stackable, usable also for micro-wave

Art.-Nr./code	Inhalt / volume (l)	ø (mm)	Höhe / height (mm)	VE/unit
290000	1,0	190	79	1
290010	2,5	240	115	1
290020	4,5	280	135	1
290030	6,0	325	147	1
290040	9,0	360	165	1
290050	13,0	400	185	1



DECKEL	d
LID	gb
COPERCHIO	it
TAPA	es

Material: Polyphropthylen, transparent

made of PP, transparent colour

Art.-Nr./code	für Schüssel Art.Nr. / for mixing bowl Art.No.	Durchmesser / Ø	VE/unit
290070	290000 (1,0 l)	190	1
290071	290010 (2,5 l)	240	1
290072	290020 (4,5 l)	280	1
290073	290030 (6,0 l)	325	1
290074	290040 (9,0 l)	360	1
290075	290050 (13,0 l)	400	1



KASSEROLLE	d
SAUCEPAN	gb
CASSERUOLA	it
CACEROLA	es

Material: PP, weiß, mit Skala in Innenseite, bruchsicher und hygienisch, auch für Mikrowellengeräte geeignet
Volumen: 2,0 Liter

*made of PP, white, with inside scale, break resistant, useable also for micorwave
volume: 2,0 ltr.*

Art.-Nr./code	Länge/length (mm)	Ø (mm)	Höhe/height (mm)	VE/unit
290200	335	190	120	1





d	SCHNEEBESEN
gb	WHISKS
it	FRUSTE, INOX, SPESSORE FILO MM. 1,6
es	BATIDORES, INOX, DIÁMETRO DE HILO 1,6 MM

Material: Edelstahl *made of stainless steel*
 handlicher Griff, für leichte Massen *wire thickness 1,6 mm,*
 Drahtstärke 1,6 mm, 24 Drähte *24 wires for light mixtures*

Art.-Nr./code	Länge / length (mm)	VE/unit
170040	250	1
170041	300	1
170042	350	1
170043	400	1
170044	450	1



d	SCHNEEBESEN
gb	WHISKS
it	FRUSTE, INOX, SPESSORE FILO MM. 2,3
es	BATIDORES, INOX, DIÁMETRO DE HILO 2,3 MM

Drähte gefasst, speziell für schwere Massen *wires connected - for heavy mixtures*
 Drahtstärke 2,3 mm, 16 Drähte *wire thickness 2,3 mm, 16 wires*

Art.-Nr./code	Länge / length (mm)	VE/unit
170050	350	1
170051	400	1
170052	450	1
170053	500	1
170054	600	1



d	SCHNEEBESEN
gb	WHISKS
it	FRUSTE, MANIGLIA NERA, SPESSORE FILO MM 1,5
es	BATIDORES, INOX, MANGO NEGRO, DIAMETRO DE HILO 1,5 MM

Material: Edelstahl; schwarzer thermo- *made of stainless steel; with black*
 plastischer, abrissfester Griff; *coloured thermoplastic fixed handle,*
 spülmaschinenfest; schwere Qualität *dishwasher safe; heavy quality, wire*
 Drahtstärke 1,5 mm; 16 Drähte *thickness 1,5 mm; 16 wires*

Art.-Nr./code	Länge / length (mm)	VE/unit
170060	250	1
170061	300	1
170062	400	1
170063	450	1



d	SEIHER
gb	STRAINER
it	COLAPASTA, PLASTICA
es	COLADOR, PLÁSTICO

Material: PP, weiß, 2 Muschelgriffe *made of polypropylene,*
with 2 shell shaped grips

Art.-Nr./code	oberer ø / top ø	unterer ø / bottom ø	Höhe / height	VE/unit
200022	360 mm	280 mm	185 mm	1



GASTRONORM - VORRATSBEHÄLTER
GASTRONORM - STORAGE CONTAINERS
 CONTENITORI GASTRONORM MULTIUSO
 CONTENEDORES GASTRONORM

d
gb
it
es

Material: Polypropylen (PP), mit Deckel
 einsetzbar von -20 °C bis +100 °C
 Mikrowellen geeignet

*made of polypropylene (PP), with lid
 useable from -20 °C up to +100 °C
 useable in microwaves*



Art.-Nr./code	Abmessungen/sizes (mm)	GN	Inhalt/volume (l)	VE/unit
230000	176 x 162 x 100	1/6	1,5	1
230001	176 x 162 x 150	1/6	2,0	1
230002	325 x 176 x 100	1/3	3,5	1
230003	325 x 176 x 150	1/3	5,0	1
230004	325 x 265 x 100	1/2	6,0	1
230005	325 x 265 x 150	1/2	7,5	1
230006	350 x 325 x 100	2/3	8,0	1
230007	350 x 325 x 150	2/3	12,0	1
230008	530 x 325 x 150	1/1	18,0	1



VORRATSDOSEN
PLASTIC CONTAINERS
 CONTENITORI QUADRI CON COPERCHIO
 CONTENEDORES CUADRADOS CON TAPA

d
gb
it
es

Material: Kunststoff, natur, inklusive
 dichtschießendem Deckel (Deckel nicht
 spülmaschinengeeignet)
 alle Größen stapelbar, bruchstabil

*made of plastic, natural, including
 hermetically sealed lid (lid not dish-
 washer safe) all sizes stackable,
 break resistant*

Art.-Nr./code	Inh./vol. (l)	Breite/width	Tiefe/depth	Höhe/height	VE/unit
230100	2,0	140 mm	170 mm	150 mm	1
230110	3,0	140 mm	170 mm	210 mm	1
230120	5,0	140 mm	170 mm	345 mm	1



VORRATSBEHÄLTER
DISPENSER
 CONTENITORI CON COPERCHIO
 CONTENEDORES CON TAPA

d
gb
it
es

Material: Polypropylen (PP), mit Klappdeckel
 (PC), spülmaschinengeeignet

*made of polypropylene (PP),
 with lid (PC), dishwasher safe*

Art.-Nr./code	Abmessungen/sizes (mm)	Inhalt/volume (l)	VE/unit
230150	500 x 160 x 95	4 x 0,7	1
230160	500 x 160 x 95	6 x 0,45	1





d	ZETTELHALTER
gb	LABEL HOLDER
it	PORTA ETIQUETTE
es	PORTA-ETIQUETAS

Material: Edelstahl *made of stainless steel*

Art.-Nr./code	Länge/length	Breite/width	Höhe/height	Gew./weight	VE/unit
191120	625 mm	15 mm	95 mm	0,76 kg	1
191121	1000 mm	15 mm	95 mm	1,40 kg	1



d	FLASCHE
gb	BOTTLES
it	FLACONI
es	FRASCOS

Material: PE, lebensmittelecht, transparent *made of PE, food-proof, transparent*

Art.-Nr./code	Inhalt/volume (ml)	ø (mm)	Höhe/height (mm)	VE/unit
200194	50	28 x 51	79	1
200195	250	61	134	1
200196	500	78	162	1
200197	1000	97,5	223,5	1



d	DOSIERSPENDER MIT DRUCKKNOPFBEDIENUNG
gb	DIRECT-ACTION DISPENSERS
it	DOSATORE
es	DISPENSADOR

Auslauf schwenkbar, *with swivelling nozzle, feed regulation*
 Dosierung manuell einstellbar *manually, including plastic container*
 inkl. Dose aus Kunststoff, natur

Art.-Nr./code	Inhalt / volume (l)	VE/unit
230103	2,0	3
230113	3,0	3
230123	5,0	3



d	GOURMET-PASSIERSIEBE
gb	GOURMET BOUILLON-SIEVES
it	COLINI PASSABRODO
es	COLADORES PARA PASAR CALDO

zum Abseihen feiner Saucen, Dämpfen, *kitchen net for straining, steaming, jam*
 Einmachen etc. *making etc.*
 Material: feinmaschiges Nylonnetz, *made of fine woven nylon cloth,*
 spülmaschinengeeignet, *dishwasher proof,*
 hitzebeständig bis +150 °C *heatresistant up to +150 °C*

Art.-Nr./code	ø (mm)	VE/unit
199095	200	1
199096	240	1

PASSIERSIEB	d
GOURMET SIEVE	gb
COLINI PASSABRODO	it
COLADORES PARA PASAR CALDO	es

mit Edelstahlgriff und Auflagehaken, extra breiter Rand *made of stainless steel, with handle extra-wide frame*

Art.-Nr./code	Durchmesser / diameter	Maschenweite / width of mash	VE/unit
199328	180 mm	0,84 mm	1



PASSIERSIEB	d
GOURMET SIEVE	gb
COLATUTTO	it
COLADOR MULTIUSO	es

mit Edelstahlgriff und Auflagehaken *made of stainless steel, with handle and hooks*

Art.-Nr./code	Durchmesser / diameter	Maschenweite / width of mash	VE/unit
199329	220 mm	1,5 mm	1
199330	260 mm	1,5 mm	1
199331	300 mm	1,5 mm	1



ZUCKERSTREUER	d
SUGAR DISPENSER	gb
SPARGIZUCCHERO CON SETACCIO	it
DOSIFICADOR PARA AZÚCAR CON TAMIZ	es

Material: Edelstahl *made of stainless steel*

Art.-Nr./code	Ausführung / type	Höhe/ height	Ø (mm)	Loch Ø (mm)	Inhalt / content (l)	VE/unit
199026	mit Sieb / with meshes	75	55	0,8	0,15	1
199027	mit Sieb / with meshes	90	65	0,8	0,25	1
199028	mit Sieb / with meshes	128	68	0,8	0,35	1
199059	kleine Lochung / small holes	75	55	1,5	0,15	1
199060	kleine Lochung / small holes	88	68	1,5	0,25	1
199061	kleine Lochung / small holes	128	68	1,5	0,35	1
199065	große Lochung / large holes	75	55	2,5	0,15	1
199063	große Lochung / large holes	90	65	2,5	0,25	1
199064	große Lochung / large holes	100	70	4,0	0,30	1





d	HALTERUNG FÜR PYRAMIDEN- UND HALBKUGEL-FORMEN
gb	SUPPORT FOR PYRAMID- AND HALF-SPHERE MOULDS
it	VASO PORTA STAMPO PIRAMIDE & SEMISFERA
es	SOPORTE PARA MOLDE PIRÁMIDE & SEMIESFERA

Material: Edelstahl, Materialstärke 1,0 mm
hochglänzend mit 4 Löcher á 30 mm und
3 Löcher á 50 mm, beidseitig verwendbar

*Made of stainless steel, thickness 1,0 mm,
high gloss with 4 holes diameter 30 mm
and 3 holes diameter 50 mm, both sides
usable*

Art.-Nr./code	Länge/length (mm)	Breite/width (mm)	Höhe/height (mm)	VE/unit
193025	500	70	70	1

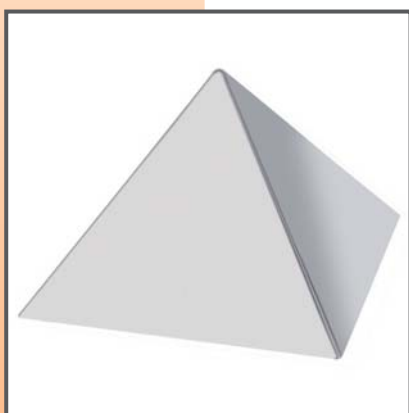

d	PYRAMIDEN-FORMEN
gb	PYRAMID MOULDS
it	STAMPO PIRAMIDE
es	MOLDE PIRÁMIDE

Art.-Nr./code	Länge/length (mm)	Breite/width (mm)	Höhe/height (mm)	VE/unit
193000	40	40	27	1
193001	60	60	40	1
193002	75	75	52	1
193003	90	90	60	1
193004	120	120	80	1
193005	150	150	100	1
193006	170	170	120	1
193007	190	190	130	1



d	HALBKUGEL-FORMEN
gb	HALF-SPHERE MOULD
it	STAMPO SEMISFERA
es	MOLDE SEMIESFERA

Art.-Nr./code	ø (mm)	Höhe/height (mm)	VE/unit
193010	40	20	1
193011	60	30	1
193012	70	35	1
193013	80	40	1
193014	90	45	1
193015	100	50	1
193016	120	60	1
193017	140	70	1
193018	160	80	1
193019	180	90	1
193020	200	100	1



d	DARIOLFORMEN
gb	CREAM TART MOULDS (DARIOL MOULDS)
it	STAMPI DA DARIOLE
es	MOLDES PARA DARIOLES

Material: Edelstahl

made of stainless steel

Art.-Nr./code	ø (mm)	Volumen (ml)	Höhe/height (mm)	VE/unit
199409	45	45	40	1
199410	55	70	50	1
199411	65	100	60	1
199412	85	150	80	1

DARIOLFORMEN
CREAM TART MOULDS (DARIOL MOULDS)
 STAMPI DA DARIOLE
 MOLDES PARA DARIOLES

d
 gb
 it
 es

Material: Aluminium *made of aluminium*

Art.-Nr./code	ø (mm)	Volumen (ml)	Höhe/height (mm)	VE/unit
997950	50	70	50	6
997951	60	110	52	6
997952	70	150	60	6
997953	80	190	75	6



CREME-FORMEN
YULE LOG MOULDS
 STAMPI PER TRONCO, TONDI
 MOLDES MEDIA CAÑA PARA CREMA REDONDOS

d
 gb
 it
 es

Material: Edelstahl *made of stainless steel*
 Ausführung: geschlossene Form *execution: self-contained*
 Design: rund *design: round*

Art.-Nr./code	Länge/length (mm)	Breite/width (mm)	Höhe/height (mm)	VE/unit
193030	500	50	37	1
193031	500	60	45	1
193032	500	70	50	1
193033	500	80	62	1



Material: Edelstahl *made of stainless steel*
 Ausführung: offene Form *execution: removable ends*
 Design: rund *design: round*

Art.-Nr./code	Länge/length (mm)	Breite/width (mm)	Höhe/height (mm)	VE/unit
193040	500	85	70	1



Material: Edelstahl *made of stainless steel*
 Ausführung: offene Form *execution: removable ends*
 Design: Trapez *design: trapezoidal*

Art.-Nr./code	Länge/length (mm)	Breite/width (mm)	Höhe/height (mm)	VE/unit
193041	600	90	75	1



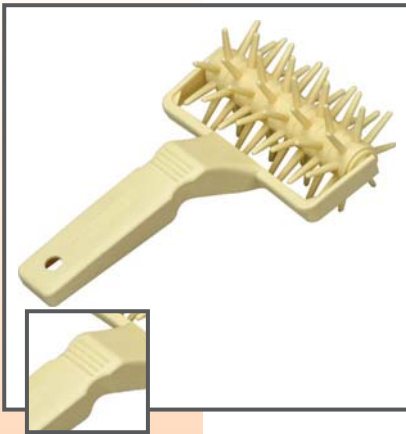

d	STIPPROLLER
gb	ROLLER DOCKERS
it	RULLI BUCASFOGLIA
es	RODILLOS PARA PINCHAR HOJALDRE

Material: Kunststoff (POM), elfenbein
mit verstärktem Kunststoffgriff

*made of plastic (POM), ivory
with reinforced plastic handle*

Art.-Nr./code	Breite/width (mm)	VE/unit
200001	65	1
200002	120	1



d	TEIGSCHNEIDER
gb	EXPANDABLE DOUGH CUTTERS
it	TAGLIAPASTA ESTENSIBILE (BICICLETTA)
es	CORTADOR EXTENSIBLE - BICICLETA

Messer: Edelstahl, rostfrei, sehr stabile
Ausführung, Schnittbreite max. 125 mm
Rädchen-Durchmesser 55 mm

*knives made of stainless steel, very
strong quality, width between wheels
max. 125 mm; wheel diameter 55 mm*

Art.-Nr./code	Ausführung / type	VE/unit
153100	5 Rädchen glatt / 5 wheels plain	1



d	DREIECK-AUSSTECHEWALZEN
gb	TRIANGULAR CROISSANT CUTTERS
it	RULLI TAGLIA CROISSANTS
es	RODILLOS PARA CORTAR CROISSANTS

für Croissants; Material: Edelstahl,
ergonomischer Kunststoffgriff

*for croissants; made of stainless steel,
ergonomic plastic handle*

Art.-Nr./code	Ausführung/type	Ausstechmaße/cutting sizes (mm)	VE/unit
154420	einfach / single	a=110, h=150	1
154421	einfach / single	a=180, h=140	1
154422	einfach / single	a=180, h=200	1
154499	einfach / single	a=97, h=210	1
154427	doppelt / double	a=180, h=200	1
154430	dreifach / triple	a=180, h=200	1
154429	dreifach / triple	a=180, h=140	1

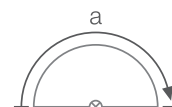
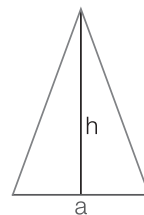

TEIG- UND PIZZASCHNEIDER	d
DOUGH AND PIZZA CUTTER	gb
ROTELLA TAGLIA PASTA E PIZZA, LISCIA	it
RUEDECILLA (PARA MASA Y PIZZA) LISA	es

Material: Edelstahl, mit ergonomischem Griff *made of stainless steel, ergonomic handle*
 aus schwarzem PP; ca. 200 mm lang *made of black PP; ca. 200 mm length*

Art.-Nr./code	Ausführung/type	ø (mm)	VE/unit
200510	einfach, glatt / <i>single, plain</i>	40	1
200511	einfach, glatt / <i>single, plain</i>	55	1
200512	einfach, glatt / <i>single, plain</i>	65	1



TEIG- UND PIZZASCHNEIDER	d
DOUGH AND PIZZA CUTTER	gb
ROTELLA TAGLIA PASTA E PIZZA, FESTONATA	it
RUEDECILLA (PARA MASA Y PIZZA), RIZADA	es

Material: Edelstahl, mit ergonomischem Griff *made of stainless steel, ergonomic handle*
 aus schwarzem PP; ca. 200 mm lang *made of black PP; ca. 200 mm length*

Art.-Nr./code	Ausführung/type	ø (mm)	VE/unit
200515	einfach gewellt / <i>single serrated</i>	40	1
200516	einfach gewellt / <i>single serrated</i>	55	1
200517	einfach gewellt / <i>single serrated</i>	65	1



PIZZATEILER	d
PIZZA CHOPPER	gb
TRONCHETTO TAGLIAPIZZA	it
CORTADOR DE PIZZA	es

Material: Edelstahl *made of stainless steel*
 Materialstärke: 1,0 mm *thickness 1,0 mm*
 Runder Griff *with round handle*

Art.-Nr./code	Breite/width (mm)	Höhe/height (mm)	VE/unit
200625	304	95	1
200626	348	93	1
200627	400	97	1





d	PIZZAWENDER / PFANNENWENDER
gb	PIZZA FLIPPERS / PAN FLIPPERS
it	PALETTA PER PASTICCIO E PIZZA / PALETTA HAMBURGER
es	ESPÁTULA PIZZA / ESPÁTULA HAMBURGER

Art.-Nr./code	Klingenlänge / dimensions	VE/unit
260000	11 cm	6
260010	24 cm	6



d	PALETTE STUMPF
gb	SPATULAS BLUNT
it	PALETTA SMUSSATA
es	ESPÁTULA SIN FILO

Art.-Nr./code	Klingenlänge / dimensions	VE/unit
260030	16 cm	6
260031	21 cm	6
260032	26 cm	6
260033	31 cm	6
260034	36 cm	6
260035	11,5 cm	6



d	WINKELPALETTE
gb	SPATULAS ANGULAR
it	PALETTA CUOCO CON SCALINO
es	ESPÁTULA DE PASTELLERO CURVADA

Art.-Nr./code	Klingenlänge / dimensions	VE/unit
260040	16 cm	6
260041	21 cm	6
260042	26 cm	6
260043	31 cm	6
260044	11,5 cm	6



d	TORTENRINGPALETTE 90°
gb	TARTRING SPATULAS 90°
it	PALETTA PER ANELLO DA TORTA 90°
es	ESPÁTULA PARA ARO DE TARTAS 90°

Art.-Nr./code	Klingenlänge / dimensions	VE/unit
260050	15 cm	6

KUCHENPALETTEN
CAKE SPATULAS
 PALETTA DA TORTA
 ESPÁTULA PARA PASTELES

d
 gb
 it
 es

Art.-Nr./code	Ausführung/type	Klingenlänge/dimensions	VE/unit
260015	gerade/straight	14 cm	6
260020	stumpf/blunt	16 cm	6
260021	Welle stumpf/single wave	16 cm	6



KUCHEN- UND KÜCHENMESSER
CAKE AND PASTRY KNIVES
 COLTELLO DA TORTA E PASTICCERIA
 CUCHILLO PARA TARTA Y PASTELERÍA

d
 gb
 it
 es

Art.-Nr./code	Ausführung/type	Maße/dimensions	VE/unit
260650	Schneide/plain	 31 cm	6
260651	Säge/saw	 31 cm	6
260652	Welle/wave	 31 cm	6

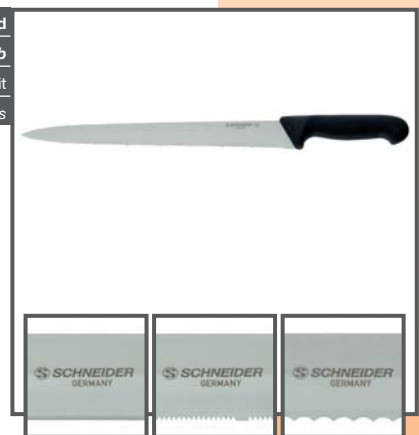

UNIVERSALMESSER
UNIVERSAL KNIVES
 COLTELLO UNIVERSALE
 CUCHILLO UNIVERSÁL

d
 gb
 it
 es

Art.-Nr./code	Ausführung/type	Maße/dimensions	VE/unit
260700	Welle/wave	 25 cm	6



UNIVERSALMESSER WELLE
UNIVERSAL KNIVES WAVE
 COLTELLO CUCINA DENTATO
 CUCHILLO COCINA, DENTADO

d
 gb
 it
 es

Art.-Nr./code	Ausführung/type	Maße/dimensions	VE/unit
260820	Welle/wave	 13 cm	6





d	KOCHMESSER
gb	CHEF'S KNIVES
it	COLTELLO CUCINA
es	CUCHILLO COCINA

Art.-Nr./code	Ausführung/type	Maße/dimensions	VE/unit
260800	Schneide/plain	20 cm	6
260801	Schneide/plain	26 cm	6
260802	Schneide/plain	31 cm	6



d	KOCHMESSER
gb	CHEF'S KNIVES
it	COLTELLO CUCINA
es	CUCHILLO COCINA

Art.-Nr./code	Ausführung/type	Maße/dimensions	VE/unit
260860	Schneide/plain	8 cm	6



d	ABZIEHSTAHL/WETZSTAHL RUND
gb	SHARPENING STEELS ROUND
it	ACCIAINO
es	AFILADOR

Art.-Nr./code	Maße/dimensions	VE/unit
260900	25 cm	1
260901	31 cm	1



d	MAGNETLEISTE
gb	MAGNET BAR
it	LISTELLO MAGNETICO
es	LISTEL MAGNETICO

inklusive Befestigungsmaterial *including fittings*

Art.-Nr./code	Maße/dimensions	VE/unit
260910	50 cm	1

KÜCHENMESSER	d
KITCHEN KNIVES	gb
COLTELLO CUCINA	it
CUCHILLO COCINA	es

Art.-Nr./code	Ausführung / type	Maße / dimensions	VE/unit
260810	Schneide/plain	13 cm	6



FILIERMESSER	d
FILLETING KNIVES	gb
COLTELLO PER FILETTARE	it
CUCHILLO PARA FILETEAR	es

Art.-Nr./code	Ausführung / type	Maße / dimensions	VE/unit
260850	Schneide/plain	16 cm	6



MESSER-ABSTREIFBEHÄLTER - STANDGERÄT	d
STANDING KNIFE CLEANER - WITH SOCKET	gb
CONTENITORE DA PULIZIA COLTELLI - DA BANCO	it
CONTENEDOR DE LIMPIEZA CUCHILLOS - PARA MESA	es

Material: Edelstahl, mit Schlitzdeckel, unbeheizt
made of stainless steel, with slot cover, without heating

Art.-Nr./code	Höhe/height	Innen-/inner ø	Boden-/bottom ø	VE/unit
270000	180 mm	100 mm	130 mm	1



SCHNEIDEBRETTER	d
CUTTING BOARDS	gb
TAGLIERI	it
TABLAS DE CORTE	es

Material: HD-PE mit Antirutsch-Füßen
made of HD-PE with anti-slip-feet

Art.-Nr./code	Abmessungen / dimensions	VE/unit
228126	400 x 300 x 15 mm	1
228127	530 x 320 x 20 mm	1





d	ROLLHÖLZER
gb	ROLLING PINS
it	RULLI IN LEGNO
es	RODILLOS AMASADORES EN MADERA

Material: Buchenholz, mit Präzisionskugellager, *made of beech wood, with precision ball-bearing, roller diameter: 90 mm*
 Walzen-Durchmesser: 90 mm

Art.-Nr./code	Walzenbreite / length of roller (mm)	VE/unit
200160	250	1
200161	300	1
200162	350	1
200163	400	1
200164	450	1

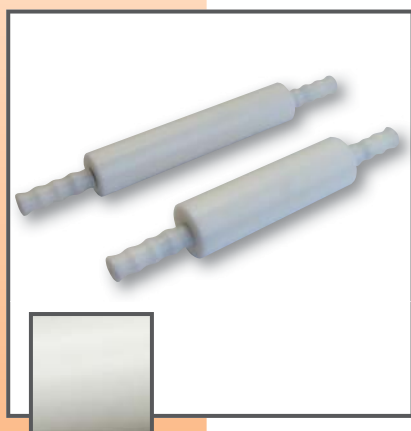

d	ROLLHÖLZER
gb	ROLLING PINS
it	RULLI IN PLASTICA
es	RODILLOS AMASADORES, PLÁSTICO

Vollkunststoff (PE), hygienisch, einfach zu reinigen, mit Edelstahlwelle *made of solid polyethylene, hygienic, easy to clean, shaft stainless steel roller diameter: 80mm*
 Walzendurchmesser: 80mm

Art.-Nr./code	Walzenbreite / length of roller (mm)	VE/unit
200126	300	1
200127	400	1
200128	450	1
200129	500	1

d	TEIGABSTECHER / KESSELSCHABER
gb	SCRAPERS / BOWL SCRAPERS
it	RASCHIETTI / RASCHIETTI PER BASTARDELLA
es	RASQUETAS / RASQUETAS PARA CALDEROS

Art.-Nr./code	Abmessungen / sizes	Ausführung / type	VE/unit
227350	221 x 130 mm	eckig / with edges	100
227351	209 x 130 mm	rund / round edges	100
227364	125 x 100 mm	eckig / with edges	100
227230	120 x 100 mm	eckig / with edges	100
227352	128 x 90 mm	asymmetrisch / asymmetrical	100
227355	120 x 80 mm	Cremeschaber / cream scraper	100
227356	151 x 102 mm	Cremeschaber / cream scraper	100
227360	112 x 78 mm	Kamm / comb	100
227365	116 x 78 mm	rund / round	100
227231	137 x 86 mm	Cremeschaber / cream scraper	100
227232	120 x 88 mm	Cremeschaber / cream scraper	100
227363	204 x 151 mm	Kesselschaber / bowl scraper	100
227233	160 x 120 mm	Kesselschaber / bowl scraper	100

227240	148 x 99 mm	rund / round	100
227241	137 x 86 mm	rund / round	100
227242	160 x 120 mm	Kesselschaber / bowl scraper	100
227243	120 x 86 mm	asymmetrisch / asymmetrical	100
227244	120 x 88 mm	rund / round	100

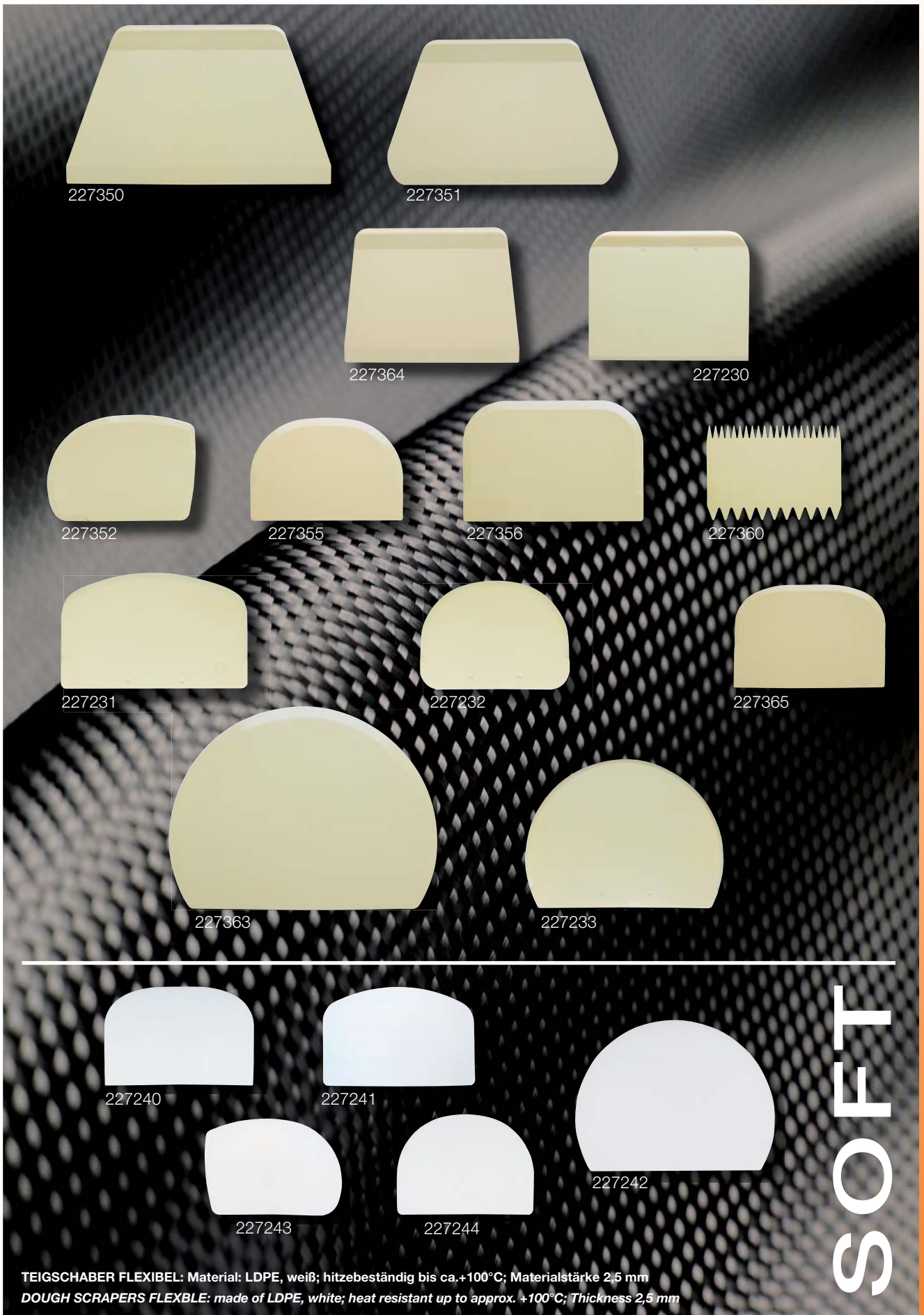

227350

227351

227364

227230

227352

227355

227356

227360

227231

227232

227365

227363

227233

227240

227241

227242

227243

227244

TEIGSCHABER FLEXIBEL: Material: LDPE, weiß; hitzebeständig bis ca.+100°C; Materialstärke 2,5 mm
 DOUGH SCRAPERS FLEXBLE: made of LDPE, white; heat resistant up to approx. +100°C; Thickness 2,5 mm

SOFT



d	STIELSCHABER
gb	SPATULAS
it	SPATOLE
es	ESPÁTULAS

Schaber: Gummi
Griff: Polystyrol

scraper: rubber
handle: polystyrene

Art.-Nr./code	Länge / length (mm)	Ausführung/ type	VE/unit
200902	260	klein / small	1
200903	270	mittel / middle	1
200904	330	groß / large	1



d	STIELSCHABER
gb	SPATULAS
it	SPATOLE IN SILICONE
es	ESPÁTULAS EN SILICONA

Material: Silikon, mit Metallstiel
bis + 300 °C

made of silicone, with metal handle
up to + 300 °C

Art.-Nr./code	Länge / length (mm)	Ausführung/ type	VE/unit
200926	285	mittel / middle	1
200927	325	groß / large	1



d	RÜHRSPATEL
gb	SPATULAS
it	SPATOLE PER TEMPERARE
es	ESPÁTULAS PARA DILUIR

Material: Polyamid/Nylon, glasfaserverstärkt,
hitzebeständig bis 220 °C, hygienisch

made of polyamide/nylon, heat resistant
up to 220 °C, hygienic

Art.-Nr./code	Länge / length (mm)	VE/unit
200930	250	6
200931	300	6
200932	350	6
200933	400	6
200934	450	6
200935	500	6



d	RÜHRKEULE
gb	SPOON
it	CUCCHIAIO
es	CUCHARA

Material: Buchenholz

made of beech wood

Art.-Nr./code	Länge/length (mm)	VE/unit
203423	300	1
203424	350	1
203425	400	1
203426	450	1
203427	500	1
203428	600	1

SPACHEL
SPATULAS
 SPATOLE TRIANGOLARI, MANIGLIA NERA
 ESPÁTULAS TRIANGULARES, MANGO NEGRO

d
 gb
 it
 es

Material: Edelstahl, *made of stainless steel,*
 Kunststoffgriff schwarz (PP) *black plastic handle (PP)*

Art.-Nr./code	Breite / width (mm)	VE/unit
200500	40	1
200501	60	1
200502	80	1
200503	100	1
200504	120	1



ABSTECHE
CUTTERS
 TAGLIAPASTA, MANIGLIA NERA
 CORTADORES DE PASTA, MANGO NEGRO

d
 gb
 it
 es

Material: Edelstahl, Kunststoffgriff schwarz, *made of stainless steel, black*
 Ecken abgerundet *plastic handle, round edges*

Art.-Nr./code	Abm. / sizes (mm)	Ausführung / type	VE/unit
200600	110 x 120	weicher Griff / flexible handle (PE)	1
200601	120 x 120	harter Griff / solid handle (PP)	1
200602	135 x 135	harter Griff / solid handle (PP)	1



PINSEL
BRUSHES
 PENNELLI
 PINCELES

d
 gb
 it
 es

Stiel PE, weißgebleichte, naphthalinfreie *stick made of polyethylene,*
 Borsten *bleached bristles*

Art.-Nr./code	Breite / width (mm)	VE/unit
200290	40	1
200291	50	1
200292	60	1
200293	75	1



PINSEL "SILIKON"
BRUSHES "SILICONE"
 PENNELLI IN SILICONE
 PINCELES EN SILICONA

d
 gb
 it
 es

Material: Silikon, mit Metallstiel, 5-reihig, *made of silicone, with metal handle,*
 bis + 300 °C *5 rows, up to + 300 °C*

Art.-Nr./code	Breite / width (mm)	VE/unit
200299	50	1





d EINWEG-SPRITZBEUTEL - GEROLLT
gb DISPOSABLE PASTRY BAGS - ON ROLLS
it SACCHETTI PER DECORARE, MONOUSO, ROTOLO
es MANGAS DESECHABLES EN ROLLO

Material: PE, **doppelt extrudiert**, Außenseite sehr griffig, Innenseite glatt, mit Abreißperforation, blau-transparent, hygienisch, Spitze geschlossen, mit oder ohne Tülle verwendbar, hohe Reißfestigkeit der Schweißnaht; Karton mit Entnahmeöffnung

*made of PE, **multiple layers**, non-slip exterior, silky inner surface for maximum product flow, blue-transparent, fast & safe perforation tear-off, hygienic, closed tip, can be used with or without tube for decorating purposes, high burst resistance on single side seal; Box with convenient dispenser*

Art.-Nr./code	Länge/length (mm)	Breite/width (mm)	Materialstärke/thickness (μ)	VE/unit
391200	350	195	75	100/Box
391210	470	230	75	100/Box
391220	530	275	75	100/Box
391230	600	300	75	100/Box

Sondergrößen und individueller Aufdruck auf Anfrage / *special sizes and individual imprint upon request*



d EINWEG-SPRITZBEUTEL - GEROLLT "ORANGE"
gb DISPOSABLE PASTRY BAGS - ON ROLLS "ORANGE"
it SACCHETTI PER DECORARE, MONOUSO, ROTOLO "ARANCIO"
es MANGAS DESECHABLES EN ROLLO "COLOR NARANJA"

Material: PE, **dreifach extrudiert**, für alle Massen (warm, kalt, fest) geeignet. „Anti-Rutsch“-Außenseite, sehr griffig, Innenseite glatt, mit Abreißperforation, orange-transparent, hygienisch, Spitze geschlossen, mit oder ohne Tülle verwendbar, hohe Reißfestigkeit der Schweißnaht; Karton mit Entnahmeöffnung

*made of PE, **3-layers**, for all kinds of purposes (warm, cold, thick), Additional temperature resistant inner layer (smooth) to insure top performance even when filled with warm contents, multiple layers, anti-slip outer surface, securing a firm grip and giving maximum control during use, silky inner surface for maximum product flow, orange-transparent, fast & safe perforation tear-off, hygienic, closed tip, can be used with or without tube for decorating purposes, high burst resistance on single side seal; Box with convenient dispenser*

Art.-Nr./code	Länge/length (mm)	Breite/width (mm)	Materialstärke/thickness (μ)	VE/unit
391310	530	275	110	50/Box

Sondergrößen und individueller Aufdruck auf Anfrage / *special sizes and individual imprint upon request*



d EINWEG-SPRITZBEUTEL „ECO“ - GEROLLT
gb DISPOSABLE PASTRY BAGS "ECO" - ON ROLLS
it SACCHETTI PER DECORARE "ECO", MONOUSO, ROTOLO
es MANGAS DESECHABLES EN ROLLO "ECO"

Material: PE, **doppelt extrudiert**, Innenseite glatt, mit Abreißperforation, transparent, hygienisch, Spitze geschlossen, mit oder ohne Tülle verwendbar, hohe Reißfestigkeit der Schweißnaht; Karton mit Entnahmeöffnung

*made of PE, **multiple layers**, silky inner surface for maximum product flow, transparent, fast & safe perforation tear-off, hygienic, closed tip, can be used with or without tube for decorating purposes, high burst resistance on single side seal; Box with convenient dispenser*

Art.-Nr./code	Länge/length (mm)	Breite/width (mm)	Materialstärke/thickness (μ)	VE/unit
391700	530	275	75	100/Box

Sondergrößen und individueller Aufdruck auf Anfrage / *special sizes and individual imprint upon request*

SPRITZBEUTEL "MASTERFLEX"	d
PASTRY BAG "MASTERFLEX"	gb
SACCHETTO PER DECORARE "MASTERFLEX"	it
MANGA "MASTERFLEX"	es

Spezialmaterial für höchste Ansprüche, 100 % lebensmittelecht, Längsnaht verschweißt, mit Aufhänger, Innenseite glatt, Außenseite griffig, flexibles Material, undurchlässig, auch für Mikrowelle geeignet

special material for highest requirements, 100 % food safe, welded seam, with hook, inside surface smooth, external surface grippy, flexible material, impermeable, useable in microwave

Art.-Nr./code	Größe/size	Länge/length (mm)	VE/unit
330002	2	340	10
330003	3	400	10
330004	4	460	10
330005	5	500	10
330007	7	600	10



SPRITZBEUTEL "EXPORT"	d
PASTRY BAG "EXPORT"	gb
SACCHETTO PER DECORARE "EXPORT", CON ORLO	it
MANGA "EXPORT", CON DOBLADILLO	es

mit Saum und Tüllenverstärkung, Baumwollgewebe mit starker Spezialbeschichtung, lebensmittelecht, verschweißte Längsnaht, mehrmals verwendbar, undurchlässig

with upper seam and reinforced tip, cotton fabric with strong special coating, food safe, welded seam, useable several times, impermeable

Art.-Nr./code	Größe/size	Länge/length (mm)	VE/unit
350080	0	250	1
350081	1	280	1
350082	2	340	1
350083	3	400	1
350084	4	460	1
350085	5	500	1
350086	6	550	1
350087	7	600	1
350088	8	650	1
350089	9	700	1
350090	10	750	1



SPRITZBEUTEL "STANDARD"	d
PASTRY BAG "STANDARD"	gb
SACCHETTO PER DECORARE "STANDARD", CON ORLO	it
MANGA "STANDARD", CON DOBLADILLO	es

mit Saum und Tüllenverstärkung, Baumwollgewebe mit starker Spezialbeschichtung, lebensmittelecht, verschweißte Längsnaht, mehrmals verwendbar, undurchlässig

with upper seam and reinforced tip, cotton fabric with strong special coating, food safe welded seam, useable several times, impermeable

Art.-Nr./code	Größe/size	Länge/length (mm)	VE/unit
350170	0	250	1
350171	1	280	1
350172	2	340	1
350173	3	400	1
350174	4	460	1
350175	5	500	1
350176	6	550	1
350177	7	600	1
350178	8	650	1
350179	9	700	1
350180	10	750	1





d TORTEN- UND DEKORIERPLATTE, DREHBAR

gb TILTING TURNTABLE

it ALZATA TORTA, GIREVOLE E ORIENTABILE

es SOPORTE GIRATORIO RECLINABLE

Melamin, Kunststoff, dreh- und schwenkbar, stabile Qualität inkl. Anti-Rutsch-Füßen, Anti-Rutsch-Oberfläche

made of melamin, plastic, turnable, tilting solid execution with anti-slip feet, anti-wobble top

Art.-Nr./code	Ø (mm)	Höhe/height (mm)	VE/unit
227220	300	160	1



d SPRITZBEUTEL-WANDAUFHÄNGER

gb WALL RACK FOR PASTRY BAGS

it ESPOSITORE PER SACCHETTI E BOCCHETTE, RIVESTITO

es SECADOR DE MANGAS Y BOQUILLAS, RECUBIERTO

sehr stabile Ausführung, weiß beschichtet, verpackt im Einzelkarton, für 4 Spritzbeutel und 31 Tüllen maximal verwendbar, inkl. Kleingeräteablage und 5 Haken

very strong execution, coated in white plastic, single packing, for 4 pastry bags and 31 piping tubes; with rack for depositing small tools, with 5 hooks

Art.-Nr./code	Breite/width (mm)	Höhe/height	VE/unit
157000	500	500	1



d SPRITZBEUTEL-WANDAUFHÄNGER, EDELSTAHL

gb WALL RACK FOR PASTRY BAGS, STAINLESS STEEL

it ESPOSITORE PER SACCHETTI E BOCCHETTE, ACCIAIO INOX

es COLGADOR- SECADOR DE MANGAS Y BOQUILLAS, ACERO INOXIDABLE

sehr stabile Ausführung, Edelstahl rostfrei, verpackt im Einzelkarton, für 4 Spritzbeutel und 31 Tüllen maximal verwendbar, inkl. Kleingeräteablage und 5 Haken

made of stainless steel, very strong execution, single packing, for 4 pastry bags and 31 piping tubes; with rack for depositing; small tools, with 5 hooks

Art.-Nr./code	Breite/width (mm)	Höhe/height	VE/unit
157001	500	500	1

STERNTÜLLEN-SATZ	d
SET OF STAR TUBES	gb
SET DI BOCCHETTE FORO STELLA, UNIPEZZO	it
JUEGO DE BOQUILLAS ESTRELLA, MONOBLOQUE	es

Material: Edelstahl, **aus einem Stück gezogen** *made of stainless steel - in one piece*

Art.-Nr./code	ø (mm)	VE/unit
197136	Satz 10-teilig / set 10 pcs.	1 Set
	4, 5, 6, 7, 8, 9, 10, 12, 13, 15 mm	



LOCHTÜLLEN	d
PLAIN TUBES	gb
SET DI BOCCHETTE FORO TONDO, UNIPEZZO	it
JUEGO DE BOQUILLAS LISAS, MONOBLOQUE	es

Material: Edelstahl, **aus einem Stück gezogen** *made of stainless steel - in one piece*

Art.-Nr./code	ø (mm)	VE/unit
197180	Satz 10-teilig / set 10 pcs.	1 Set
	4, 5, 6, 7, 8, 9, 10, 12, 13, 15 mm	



TÜLLEN-SET	d
TUBES SET	gb
SET DI BOCCHETTE	it
JUEGO DE BOQUILLAS	es

Material: PP, Farbe elfenbein *made of PP, colour ivory*
 Höhe: 6 cm *height: 6 cm*
 6 verschiedene Tüllen *6 different tubes*

Art.-Nr./code	ø (mm)	Größe/size
196530	3, 5, 7, 9, 11, 13	3, 5, 7, 9, 11, 13
196540	5, 7, 9, 11, 13, 15	3, 5, 7, 9, 11, 13



VERSCHLUSS-CLIP	d
FASTENING CLIPS	gb
CLIP DI CHIUSURA	it
CLIPS DE PLASTICO	es

Material: PP *Made of PP*
 Zum dichten Verschließen von Spritzbeutel
 und Vorratsbeutel, spülmaschinenfest *For tight closing of pastry bags and
 other bags, dishwasher safe*

Art.-Nr./code	Länge/length	Ausführung / type	VE/unit
391900	● 120 mm	mit Messer / including knife	1 Pack
391901	● 160 mm		1 Pack
391902	● 250 mm	mit Griff / with handle	1 Pack





d	TORTENTEILER EINSEITIG
gb	TART MARKER SINGLE-SIDED
it	SEGNAPORZIONI PER TORTE, UNILATERALE, IN PLASTICA
es	MARCADOR DE PASTELES UNILATERAL EN PLÁSTICO

Material: PP, elfenbein, mit 2 Handgriffen, Durchmesser 265 mm
made of PP, ivory, 2 grips, diameter 265 mm

Art.-Nr./code	Teilungen / pieces	VE/unit
220108	8	1
220110	10	1
220112	12	1
220114	14	1
220116	16	1
220118	18	1
220119	20	1



d	TORTENTEILER DOPPELSEITIG
gb	TART MARKER DOUBLE-SIDED
it	SEGNAPORZIONI PER TORTE, DOPPIO, IN PLASTICA
es	MARCADOR DE PASTELES DOBLE EN PLÁSTICO

Material: PP, elfenbein, mit 2 Handgriffen, Durchmesser 265 mm
made of PP, ivory, 2 grips, diameter 265 mm

Art.-Nr./code	Teilungen / pieces	VE/unit
220128	8/12	1
220120	12/16	1
220122	14/16	1
220124	12/18	1
220126	14/18	1



d	TORTENTEILER EINSEITIG
gb	TART MARKER SINGLE-SIDED
it	SEGNAPORZIONI PER TORTE, UNILATERALE, IN ACCIAIO INOX
es	MARCADOR DE PASTELES UNILATERAL EN ACERO INOXIDABLE

Material: Edelstahl, sehr stabile Ausführung, Durchmesser 330 mm, Höhe 28 mm
made of stainless steel, very strong quality, diameter 330 mm, height 28 mm

Art.-Nr./code	Teilungen / pieces	VE/unit
120108	8	1
120110	10	1
120112	12	1
120114	14	1
120116	16	1
120118	18	1



d	TORTENTEILER DOPPELSEITIG
gb	TART MARKER DOUBLE-SIDED
it	SEGNAPORZIONI PER TORTE, DOPPIO, IN ACCIAIO INOX
es	MARCADOR DE PASTELES DOBLE, EN ACERO INOXIDABLE

Material: Edelstahl, sehr stabile Ausführung, mit 2 Handgriffen; Ø: 330 mm, Höhe 53 mm
made of stainless steel, very strong quality, 2 grips; Ø: 330 mm, height 53 mm

Art.-Nr./code	Teilungen / pieces	VE/unit
120190	8/12	1
120191	10/12	1
120192	10/14	1
120193	10/16	1
120194	12/14	1
120195	12/16	1

ETAGEN-TORTENSTÄNDER	d
CAKE STANDS	gb
ALZATE TORTA IN ALLUMINIO	it
PEDESTALES PARA TARTAS, ALUMINIO	es

sehr stabile Ausführung, aus Aluminium
für Hochzeiten, Büffets in der Gastronomie
oder für Warenpräsentationen

*very stable execution, made of aluminium
usable for wedding cakes, buffets or for
displaying pastries etc.*

Abstand zwischen den Etagen 16,5 cm

distance between tiers 16,5 cm

Art.-Nr./code	Etagen/ tiers	Höhe/ height	Breite /width (mm)	VE/unit
146003	3	380	200/260/320	1
146004	4	546	200/260/320/400	1
146005	5	712	200/260/320/400/450	1
146006	6	878	200/260/320/400/450/500	1
146007	7	1044	160/200/260/320/400/450/500	1
146008	8	1210	160/200/260/320/400/450/500/550	1
146009	9	1376	160/200/260/320/400/450/500/550/600	1
148001			Mittellochstecher aus Edelstahl / center hole cutter made of stainless steel	1





d	PRÄSENTATIONSPLATTE
gb	PRESENTATION PLATE
it	PRESENTAZIONE PIASTRA
es	PRESENTACIÓN PLACA

Material: Melamin silber (schnitt- und bruchfest) mit Anti-Rutsch-Füßen *made of melamine, silver (cut and break proof); with anti-slip feet*

Art.-Nr./code	ø (mm)	Höhe/height (mm)	VE/unit
227229	240	30	1
227225	300	30	1
227227	320	30	1



d	PRÄSENTATIONSPLATTE
gb	PRESENTATION PLATE
it	PRESENTAZIONE PIASTRA
es	PRESENTACIÓN PLACA

Material: Melamin weiß (schnitt- und bruchfest) mit Anti-Rutsch-Füßen *made of melamine, white (cut and break proof) with anti-slip feet*

Art.-Nr./code	ø (mm)	Höhe/height (mm)	VE/unit
227029	240	30	1
227025	300	30	1
227027	320	30	1



d	PRÄSENTATIONSPLATTE
gb	PRESENTATION PLATE
it	PRESENTAZIONE PIASTRA
es	PRESENTACIÓN PLACA

Material: Melamin schwarz (schnitt- und bruchfest) mit Anti-Rutsch-Füßen *Made of melamine, black (cut and break proof), with anti-slip feet*

Art.-Nr./code	ø (mm)	Höhe/height (mm)	VE/unit
227129	240	30	1
227125	300	30	1
227127	320	30	1



ETAGEN-TORTENSTÄNDER	d
CAKE STANDS	gb
ALZATE TORTA	it
SOPORTES DE EXPOSICIÓN	es

Material: Polycarbonat *Made of polycarbonate*
 Gespiegelte Oberfläche *Mirror-Surface*
 Scheiben-Durchmesser 250 mm *Disc diameter: 250 mm*
 Höhen: 100 mm, 200 mm, 300 mm *Heights: 100 mm, 200 mm, 300 mm*

Art.-Nr./code	Abmessungen (L x B x H) /dimensions (mm)	VE/unit
201180	800 x 250 x 300	1

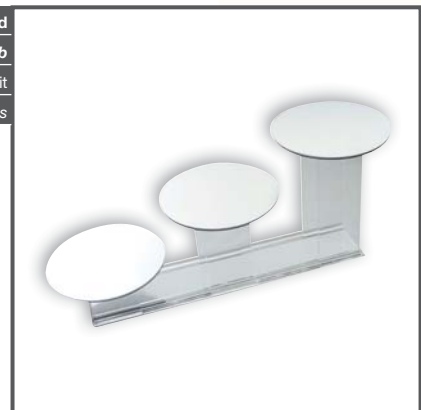

ETAGEN-TORTENSTÄNDER	d
CAKE STANDS	gb
ALZATE TORTA	it
SOPORTES DE EXPOSICIÓN	es

Material: Acryl *made of acryl*
 3 Etagen, weiss *3 tiers, white*

Art.-Nr./code	Abmessungen (L x B x H) /dimensions (mm)	VE/unit
201170	560 x 560 x 400	1



PRÄSENTATIONSSTÄNDER	d
DISPLAY STAND	gb
ALZATE DOLCI	it
SOPORTES DE EXPOSICIÓN	es

Material: Acryl *made of acryl*
 grüne Säule mit 3 weißen Ringen *green pillar with 3 white rings*

Art.-Nr./code	Abmessungen (L x B x H) /dimensions (mm)	VE/unit
201160	370 x 370 x 530	1



PRÄSENTATIONSSTÄNDER	d
DISPLAY STAND	gb
ALZATE DOLCI	it
SOPORTES DE EXPOSICIÓN	es

Material: Acryl *made of acryl*
 rote Säule mit 3 weißen Platten *red pillar with 3 white plates*

Art.-Nr./code	Abmessungen (L x B x H) /dimensions (mm)	VE/unit
201130	320 x 320 x 500	1

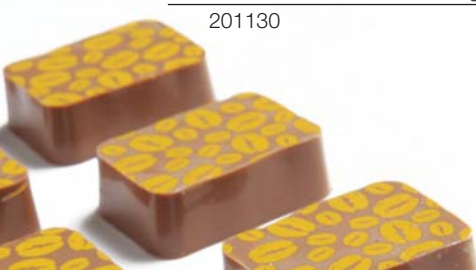



d SERVIERTABLETTS OVAL
gb SERVING TRAYS OVAL
it VASSOI OVALI
es BANDEJAS OVALADAS

Material: Edelstahl, mit gebürteltem Rand, hochglanzpoliert

made of stainless steel, with rolling edge, mirror polishing

Art.-Nr./code	Abmessungen / dimensions (mm)	VE/unit
154040	145 x 200	1
154041	180 x 230	1
154042	195 x 265	1
154043	220 x 285	1



d TORTENSPITZEN, OVAL
gb DOILIES, OVAL
it PIZZI OVALI
es BLONDAS OVALADAS

weiß

white

Art.-Nr./code	Abmessungen/sizes (mm)	VE/unit	Karton/box
116100	180 x 250	250	2000
116110	160 x 230	250	2000
116120	190 x 270	250	2000
116130	210 x 320	250	2000
116200	250 x 350	250	2000
116210	320 x 450	250	2000



d SNACK-VERKAUFSSTÄNDER
gb SNACK SALES RACK
it PORTA PANINI
es PORTA BOCADILLOS

Material: Kunststoff

made of plastic

Art.-Nr./code	Länge/length	Breite/width	Höhe/height	VE/unit
227550	600 mm	195 mm	80 mm	1



d WRAP-HALTER
gb WRAP HOLDER
it PORTA "WRAP"
es PORTA "WRAPS"

Material: Acryl, transparent, mit Boden, zur Präsentation von 12 Wraps, Lochdurchmesser 70 mm

made of acryl, transparent, with bottom, for the presentation of 12 wraps, diameter of holes 70 mm

Art.-Nr./code	Länge/length	Breite/width	Höhe/height	VE/unit
172520	560 mm	195 mm	50 mm	1

SNACK-VERKAUFSSTÄNDER WELLENFORM
SNACK SALES RACK "WAVY"
 PORTA PANINI "WAVY"
 PORTA BOCADILLOS "WAVY"

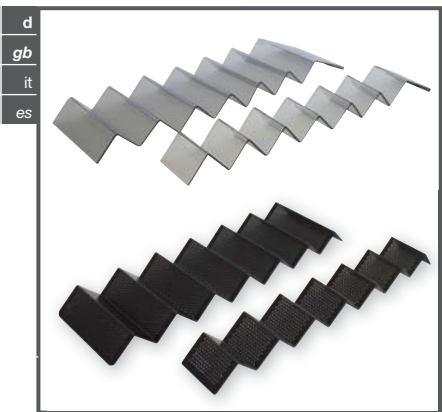

Material: Acryl, transparent *made of acryl, transparent*

Art.-Nr./code	Abmessungen/dimensions (mm)	VE/unit
172500	580 x 85	1
172510	580 x 170	1

Material: Aluminium, pulverbeschichtet, schwarz; nicht spülmaschinengeeignet *made of aluminium, black, powder coated, not dishwasher safe*

154090	580 mm	85 mm	1
154091	580 mm	170 mm	1

THEKENAUFSTELLER
SHOW CASE
 VETRINA
 VITRINA

Material: Acryl *made of acrylic*

Art.-Nr./code	Breite/width (mm)	Tiefe/depth (mm)	Höhe/height (mm)	VE/unit
172600	630	260	200	1
172610	630	260	380	1



THEKENAUFSTELLER
SHOW CASE
 VETRINA
 VITRINA

Material: Edelstahl, aus einem Stück *made of stainless steel, in one piece*

Art.-Nr./code	Länge ges. / total length	Br. vorn/width front	Ausführung/type	VE/unit
171000	190 mm	36 mm	offen/open	1
171001	185 mm	34 mm	offen/open	1
171002	180 mm	36 mm	geschl./closed	1
171003	190 mm	56 mm	breit/width	1
171004	230 mm	20 mm		
171005	145 mm	21 mm	offen/open	1

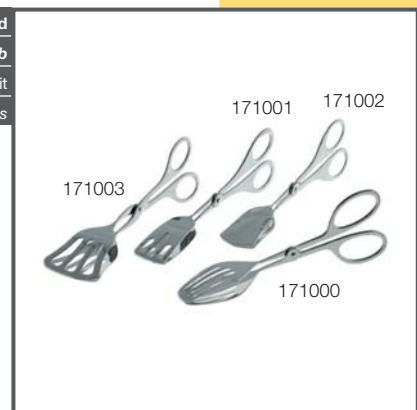



festsitender Deckel
tightly closing lid
Flächen für Beschriftungen
special surfaces for labels
mit handlichen Griffen
with ergonomic handles
Deckel durch Aussparung
einfacher zu öffnen
cover by recess easier to open



d	☪ SCHNEIDER ISOBOX "GASTRO GN 1/1"
gb	☪ SCHNEIDER ISOBOX "GASTRO GN 1/1"
it	CONTENITORE ISOTERMICO ☪ SCHNEIDER ISOBOX "GASTRO GN1/1"
es	CONTENEDOR ISOTÉRMICO ☪ SCHNEIDER ISOBOX "GASTRO GN1/1"

für Küchen, Kantinen und Catering

for foodservice, canteens and catering



Art.-Nr./code	Außenmaß/ <i>outside dim. (mm)</i>	Innenmaß/ <i>inside dim. (mm)</i>	Inh./ <i>vol. (l)</i>	Gewicht/ <i>weight (g)</i>	VE/ <i>unit</i>
280010	600 x 400 x 180	538 x 337 x 117	21	850	1
280011	600 x 400 x 230	538 x 337 x 167	30	900	1
280012	600 x 400 x 280	538 x 337 x 217	39	1000	1
280013	600 x 400 x 320	538 x 337 x 257	46	1100	1
280016	600 x 400 x 400	538 x 337 x 337	61	1400	1
280014	Ersatzdeckel / <i>replacement lid</i>				1



Art. 280016
Isobox extra hoch!

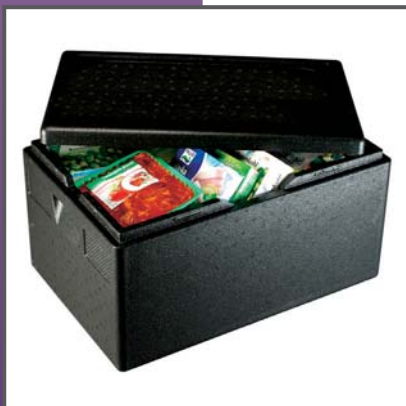

d	☪ SCHNEIDER ISOBOX "GASTRO GN 1/2"
gb	☪ SCHNEIDER ISOBOX "GASTRO GN 1/2"
it	CONTENITORE ISOTERMICO ☪ SCHNEIDER ISOBOX "GASTRO GN1/2"
es	CONTENEDOR ISOTÉRMICO ☪ SCHNEIDER ISOBOX "GASTRO GN1/2"

für Küchen, Kantinen und Catering mit
Kunststofftragebügel (PE)

*for foodservice, canteens and catering with
plastic handle (PE)*

Art.-Nr./code	Außenmaß/ <i>outside dim. (mm)</i>	Innenmaß/ <i>inside dim. (mm)</i>	Inh./ <i>vol. (l)</i>	Gewicht/ <i>weight (g)</i>	VE/ <i>unit</i>
280020	400 x 320 x 345	345 x 265 x 285	26	1000	1
280021	Ersatzdeckel / <i>replacement lid</i>				1



kalt / cold

heiß / hot

frisch / fresh

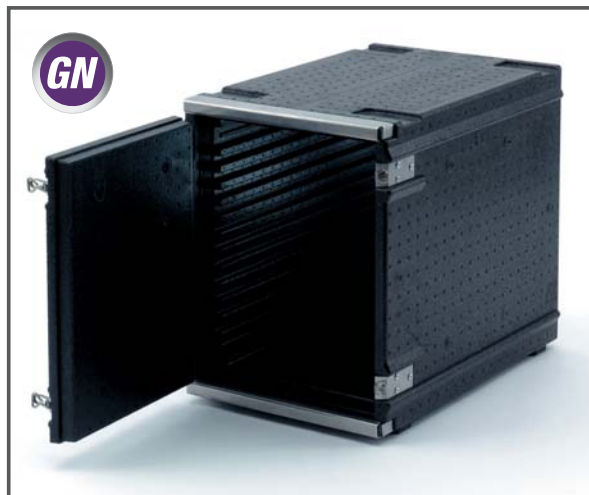

S SCHNEIDER ISOBOX "FRONTEINSCHUB GASTRO GN 1/1"	d
S SCHNEIDER ISOBOX "FRONT LOADER GASTRO GN 1/1"	gb
CONTENITORE ISOTERMICO S SCHNEIDER ISOBOX "GASTRO GN1/1"	it
CONTENEDOR ISOTÉRMICO S SCHNEIDER ISOBOX "GASTRO GN1/1"	es

mit 11 Einschüben

with 11 supports

Art.-Nr./code	Außenmaß/ outside dim. (mm)	Innenmaß/ inside dim. (mm)	Inh./ vol. (l)	Gewicht/ weight (g)	VE/ unit
280015	635 x 410 x 550	530 x 325 x 448	77	4500	1

KÜBEL	d
BUCKETS	gb
SECCHI	it
CUBOS	es

Material: HD PE, weiß, mit zwei Griffen

made of PE HD, white, with two handles

Art.-Nr./code	Inh./vol.	oberer/top ø	Boden/bottom ø	Höhe/height	VE/unit
202000	35 l	390 mm	310 mm	480 mm	1
202010	50 l	450 mm	360 mm	480 mm	1
202020	75 l	490 mm	390 mm	575 mm	1
202030	100 l	520 mm	410 mm	670 mm	1
202005	Deckel für Kübel/ lids for buckets Art. 202000				1
202015	Deckel für Kübel/ lids for buckets Art. 202010				1
202025	Deckel für Kübel/ lids for buckets Art. 202020				1
202035	Deckel für Kübel/ lids for buckets Art. 202030				1



FAHRGESTELL FÜR KÜBEL	d
TROLLEY FOR BUCKETS	gb
CARRELLO PER SECCHI TONDI	it
CARRETILLA PARA CUBOS REDONDOS	es

Material: Edelstahl, verstellbar

made of stainless steel, adjustable

Art.-Nr./code	für Art.-Nr./usable for code	VE/unit
202098	202000, 202010, 202020, 202030	1





Schneider GmbH • In der Längerts 1
D-73095 Albershausen
Tel. +49(0)71 61 / 3004-0 • Fax +49(0)71 61 / 3004-50
Email: info@schneider-gmbh.com

www.schneider-gmbh.com

